

**FULGOR**  
MILANO

12

SINCE  
PASSIONE | ITALIANA  
1949

ED 12  
REV — 02

# FULGOR

MILANO



## INDICE

PROFESSIONAL	004	174	DRAWERS
BARBECUE	052	186	HOBBS
CLUSTER	066	258	EXTRACTION
URBANTECH TOUCH	088	270	REFRIGERATION
URBANTECH	108	282	DISHWASHING
PLANO	136		
ACCESSORIES	300	312	TECHNICAL DATA

**FULGOR**  
MILANO

**SINCE 1949**

**PASSIONE ITALIANA**

FULGOR MILANO is the emblem of Italian craftsmanship. Its brand has a history spanning more than 70 years, deeply rooted in Italy's manufacturing tradition and creativity, producing unique and innovative ideas. FULGOR MILANO is synonymous with design, modernity, beauty, and functionality. The company continuously improves its flagship to meet the demands of a modern consumer who wants to use smart, high-performing appliances.

Finding ways to streamline time management is essential in today's dynamic, environmentally conscious society.

Fulgor Milano meets everyday living needs and makes new cooking and food preservation opportunities accessible, maintaining nutritional and sensory properties.

The kitchen has always been the queen of the house, a place of conviviality to share happy moments with your dear ones. Families gather in this pleasant and colourful setting every evening to share the day's happenings while unleashing their creativity to invent new dishes.

Fulgor Milano is ideal for those who love mixing and matching different flavours and ingredients to make complex recipes. By choosing FULGOR MILANO, you choose top-quality, high-tech home appliances meeting the highest demands.

*Gianni Anselmi*

General Manager

NEW

FULGOR  
MILANO

# 48 INDUCTION

## SOFIA PROFESSIONAL

The iconic SOFIA range defines the PROFESSIONAL collection by FULGOR MILANO. This high-quality product is characterized by a modern and rigorous design, a fusion of tradition and innovation.

The SOFIA induction range in the new 48" version represents a refined expression of FULGOR MILANO's design. The intuitive knob control allows for the adjustment of both the range top and the two multifunction ovens. Two variants are available: the ALL GLASS version and the GRIDDLE version with a Teppanyaki plate. Thus, the SOFIA 48" combines several cooking systems in a single product, Italian craftsmanship in steel processing, and attention to detail, fully meeting the standards of cooking enthusiasts.





Sofia Induction Griddle 48"

FSRC 4807 P MI MK 2F G X



- Electronic multifunction ovens
- Pizza Pizzeria 350 °C function
- AirFry (oven-frying) function
- Pyrolytic self-cleaning ovens
- Fast pre-heat function
- Main oven with dual convection
- Ventilated accessory oven
- Meat Probe
- Cool touch soft-close door
- Creative Digital Control with knobs
- Glass-Ceramic Surface
- Metal knobs with stainless steel finish
- Pan Detection Sensor
- 7 Cooking Zones
- 1 Dual Max Power Zone Ø 28 cm
- Trilaminare Stainless Steel Griddle

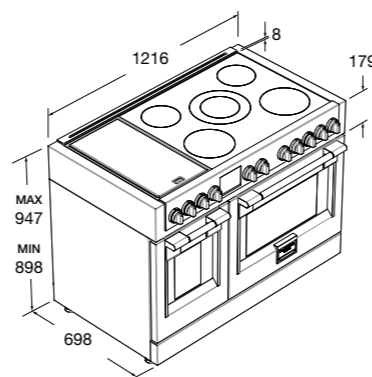

Features

The SOFIA Induction Range with Griddle, in the new 48" version, represents a refined expression of FULGOR MILANO design. The cooktop is equipped with seven powerful induction zones, including both an efficient DUAL MAX POWER and a flexible BRIDGE zone. The stainless steel Teppanyaki plate is perfect for replicating the traditional Japanese cooking and it's easily removable, significantly simplifying the cleaning of the entire cooktop. The intuitive knob control allows the adjustment of both the cooktop and the two high-performance pyrolytic multifunction ovens. The main 30" oven, along with the auxiliary 18" one, confirm SOFIA's versatility, making it a flexible tool that enhances the creativity of professional chefs. The standard accessories for the main oven, include : a fully extendable telescopic rack, two flat racks, a meat probe, a pizza set (round rack, pizza peel, and refractory stone), an enamel-coated anti-splash tray, and an AirFry tray. The auxiliary 18" oven has a fully extendable telescopic rack, two flat racks, and an AirFry tray.

Accessories on request  
Technical data

page 302  
page 314



STAINLESS STEEL  
FSRC 4807 P MI MK 2F G X  
EAN 8019801035144



MATTE BLACK  
FSRC 4807 P MI MK 2F G MBK  
EAN 8019801035151



Sofia Induction 48"

FSRC 4807 P MI MK 2F X



- Electronic multifunction ovens
- Pizza Pizzeria 350 °C function
- AirFry (oven-frying) function
- Pyrolytic self-cleaning ovens
- Fast pre-heat function
- Main oven with dual convection
- Ventilated accessory oven
- Meat Probe
- Cool touch soft-close door
- Creative Digital Control with knobs
- Glass-Ceramic Surface
- Metal knobs with stainless steel finish
- Pan Detection Sensor
- 7 Cooking Zones
- 1 Dual Max Power Zone Ø 28 cm

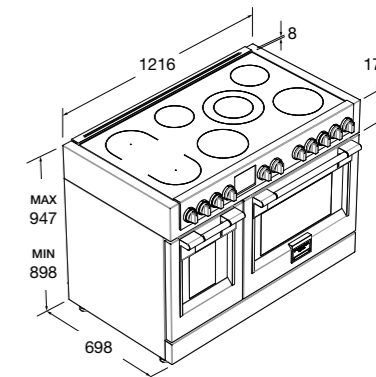

Features

The Sofia Induction range, now available in the new 48" version, represents a refined expression of FULGOR MILANO design. The cooktop is equipped with seven powerful induction zones, including both a flexible BRIDGE and an efficient DUAL MAX POWER zone. The intuitive knob control allows adjustment of both the cooktop and the two high-performance pyrolytic multifunction ovens. The main 30" oven, along with 18" auxiliary oven, confirm the versatility of SOFIA, making it a flexible tool capable of enhancing the creativity of professional chefs. The standard accessories for the main oven include a fully extendable telescopic rack, two flat racks, a meat probe, a pizza set (round rack, pizza peel, and refractory stone), an enamel-coated anti-splash tray, and an AirFry tray. The auxiliary oven has fully extendable telescopic rack, two flat racks, and an AirFry tray.

Accessories on request  
Technical data

page 302  
page 315



STAINLESS STEEL  
FSRC 4807 P MI MK 2F X  
EAN 8019801035120



MATTE BLACK  
FSRC 4807 P MI MK 2F MBK  
EAN 8019801035137



**FULGOR**  
MILANO

# 30 | 36 INDUCTION SOFIA PROFESSIONAL

The SOFIA range stands out for its iconic design and high performance. It comes with a 30 and 36 inches induction module. Fulgor Milano has fitted the oven and cooktop with a user-friendly knob control to meet the requests of professional chefs. The cooktop control display is located under the glass. The elegant glass-ceramic surface with its special anti-scratch texture is easy to clean. SOFIA is fitted with top-quality inductors ensuring durability, efficiency, and energy savings.

SOFIA's main multifunction oven features dual convection and produces a balanced airflow, ensuring even temperature. Cooking is optimized throughout the cavity's various layers. The Meat Probe monitors the food temperature, digitally controlling the cooking process. The electric grill heating element inside the cavity is ideal for grilling and browning food over high heat. Besides the classic cooking programmes, the oven includes a set of features, such as the 4-pane glass cool-touch door, soft closing system, meat probe, telescopic rails, and self-cleaning function.

SOFIA: a Modern Classic.

**FULGOR**  
MILANO

SOFIA PROFESSIONAL

# INDUZIONE

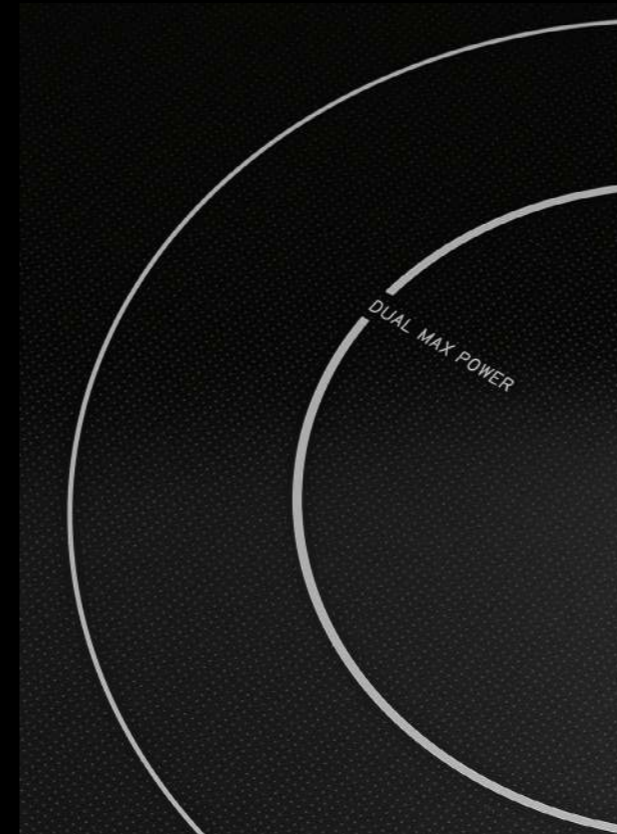

## DUAL MAX POWER

Sofia 36" features an exclusive Premium five-zone cooktop with a special anti-scratch surface. The large and powerful DUAL MAX POWER zone at the centre is incredibly versatile as it automatically recognises the pan size and choosing the cooking zone accordingly.

## KNOBS AND TIMER

The user-friendly knobs control the oven and the induction cooktop, ensuring fast cooking and efficiency while combining style, ergonomic design, and sturdiness. With the knob interface, Fulgor Milano meets the requests of professional chefs.

The digital timer helps chefs control the progress of their preparations. Its countdown is displayed on the induction cooktop.

NEW

FULGOR  
MILANO

SOFIA PROFESSIONAL  
NEW 90 CM INDUCTION

The new 90 centimeter Sofia Kitchen is a versatile and efficient product designed to maximize space. It features an exclusive five zone premium cooktop with black ceramic glass surface and under glass display. The Piro multifunction oven includes self-cleaning function (Pyrolysis), 4 glass "cold" door and soft close mechanism.



**New Induction hob 90 CM**  
FSRC 9005 P MI MK 2F X



- Professional Digit Control
- Pizza Pizzeria 350 °C function
- AirFry (oven-frying) function
- Metal knobs with stainless steel finish
- 5 cooking zones
- 1 Dual Max Power Zone - Ø 28 cm
- Glass-ceramic surface
- Pan detection sensor
- Pyrolytic Multifunction Oven
- Fast Pre-Heat BOOSTER
- Interior dual convection

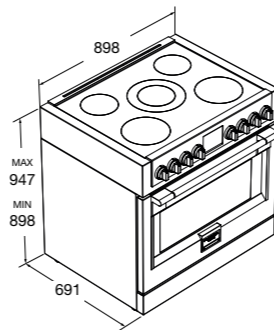

Features

Sofia 90 centimeter Induction is characterized by an exclusive five-zone Premium cooktop (knob control), the black glass-ceramic surface has an anti-scratch texture and control glass display. The DUAL MAX POWER cooking zone in the center is capable of automatically recognizing pot size. The pyro multifunction oven includes a series of features that make it unique: 4-glazed "cool" door, door soft close mechanism and self-cleaning function (Pyrolysis). The standard accessories of the oven include a fully extractable telescopic rack, a meat probe, two flat racks, a pizza set (round rack, peel and pizza stone), enameled tray with anti-splash and tray for AirFry.

Accessories on request page 302  
Technical data page 316



ACCIAIO INOX  
FSRC 9005 P MI MK 2F X  
EAN 8019801033300



MATTE BLACK  
FSRC 9005 P MI MK 2F MBK  
EAN 8019801033492



**Induction hob 36"**  
FSRC 3605 P MI MK 2F X



- Professional Digit Control
- Pizza Pizzeria 350 °C function
- AirFry (oven-frying) function
- Metal knobs with stainless steel finish
- 5 cooking zones
- 1 Dual Max Power Zone - Ø 28 cm
- Glass-ceramic surface
- Pan detection sensor
- Pyrolytic Multifunction Oven
- Fast Pre-Heat BOOSTER
- Interior dual convection

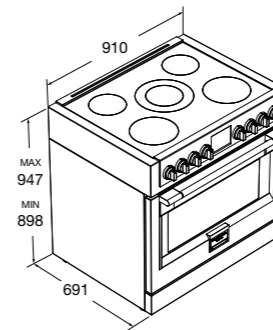

Features

Sofia 36" Induction is characterized by an exclusive five-zone Premium cooktop (knob control), the black glass-ceramic surface has an anti-scratch texture and control glass display. The DUAL MAX POWER cooking zone in the center is capable of automatically recognizing pot size. The 36" pyro multifunction oven includes a series of features that make it unique: 4-glazed "cool" door, door soft close mechanism and self-cleaning function (Pyrolysis). The standard accessories of the oven include a fully extractable telescopic rack, a meat probe, two flat racks, a pizza set (round rack, peel and pizza stone), enameled tray with anti-splash and tray for AirFry.

Accessories on request page 302  
Technical data page 316



STAINLESS STEEL  
FSRC 3605 P MI MK 2F X  
EAN 8019801031887



MATTE BLACK  
FSRC 3605 P MI MK 2F MBK  
EAN 8019801031917



**Induction hob 30"**  
FSRC 3004 P MI MK 2F X



- Professional Digit Control
- Pizza Pizzeria 350 °C function
- AirFry (oven-frying) function
- Metal knobs with stainless steel finish
- 4 cooking zones
- Glass-ceramic surface
- Pan detection sensor
- Pyrolytic Multifunction Oven
- Fast Pre-Heat BOOSTER
- Interior dual convection
- Cool touch soft-close door

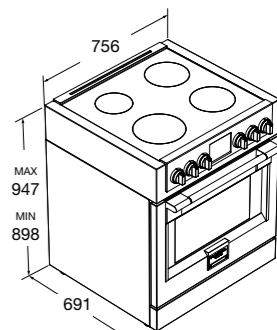

Features

Sofia PRO 30" Induction is characterized by an exclusive Premium cooktop with four cooking zones controlled by the intuitive knob control. The heavy-duty black ceramic glass surface has a special anti-scratch texture and a control display. The oven, in addition to the classic cooking modes, includes a series of features that make it unique: 4-glazed "cool" door, door soft close mechanism and self-cleaning function (Pyrolysis). The standard accessories of the oven include a fully extractable telescopic rack, a meat probe, two flat racks, a pizza set (round rack, peel and pizza stone), enameled tray with anti-splash and tray for AirFry.

Accessories on request page 302  
Technical data page 316



STAINLESS STEEL  
FSRC 3004 P MI MK 2F X  
EAN 8019801031894



MATTE BLACK  
FSRC 3004 P MI MK 2F MBK  
EAN 8019801031924

**FULGOR**  
MILANO

**SOFIA**

**PROFESSIONAL**



### CLASSIC BEAUTY

The iconic SOFIA range features a modern and rigorous Italian design where style meets technology. Fulgor Milano's Professional range ensures Italy's proverbial quality and high performance. SOFIA combines tradition and innovation, winning over international cuisine lovers.

# SOFIA PROFESSIONAL

**FULGOR**  
MILANO

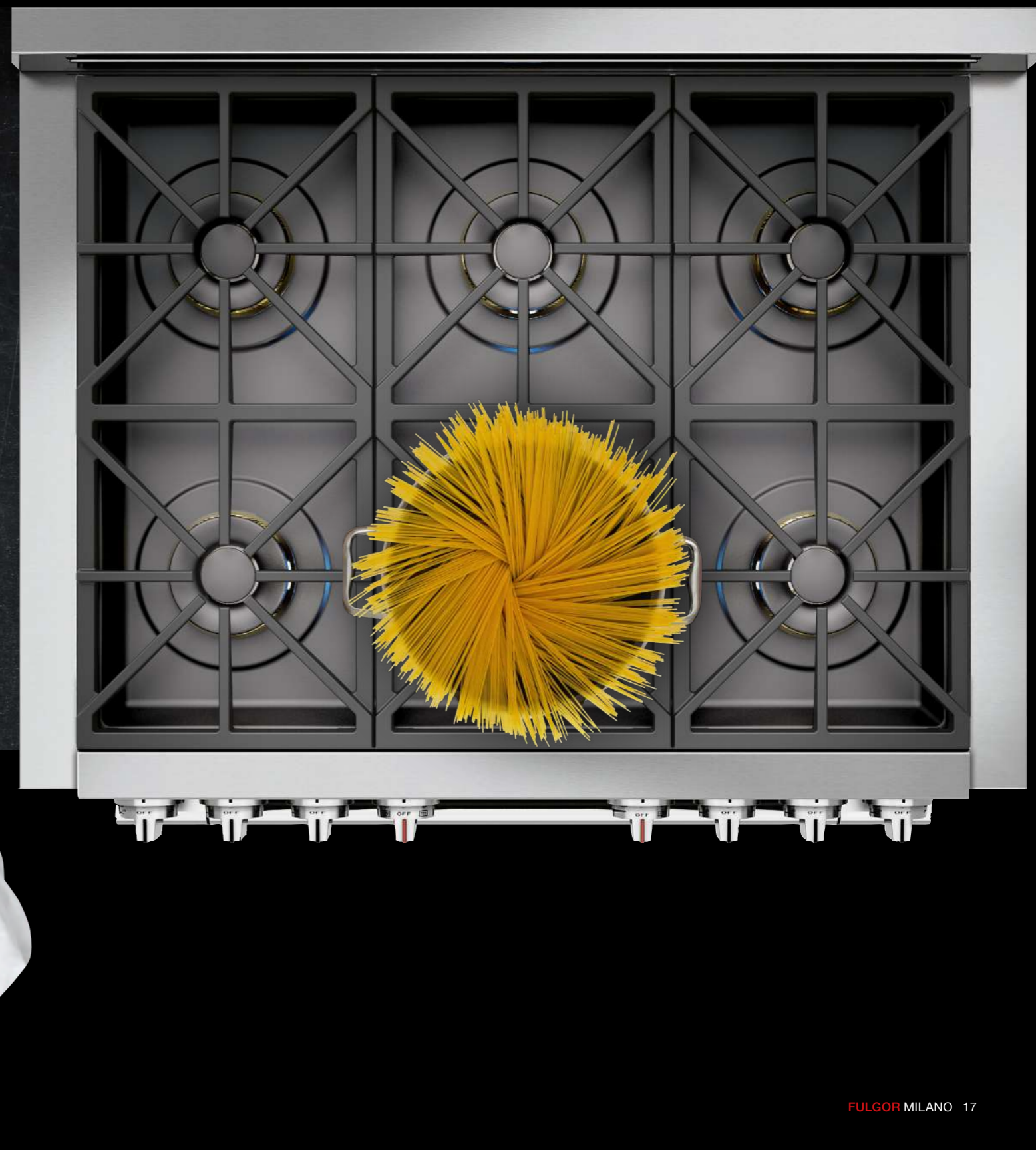

# SOFIA PROFESSIONAL

**FULGOR**  
MILANO



## SOFIA IS UNIQUE

We designed a professional Range with a unique style. Sofia integrates valuable metals such as stainless steel, brass, heavy duty cast-iron, and brushed aluminium for an elegant and distinctive design.

## CONTROL AND SENSITIVITY

The Professional range stands out in every detail. And the top cooking surface is no exception. The matte black enamelled bowl promotes cleanliness. Moreover, CRESCENDO GAS burners with 5 power levels ensure accuracy and flexibility.

## EASY ACCESS

All functions are easy to manage thanks to the user-friendly knob control and graphic interface. The user-friendly control panel allows users to easily select all the multiple oven functions as well as timer setting and meat probe.

## ARTISANAL CARE

FULGOR MILANO's multifunction range combines the characteristics of a professional product with the elegance of a craft made process, enhancing the unique Italian style.

# 5 in 1

## "CRESCENDO" BURNERS

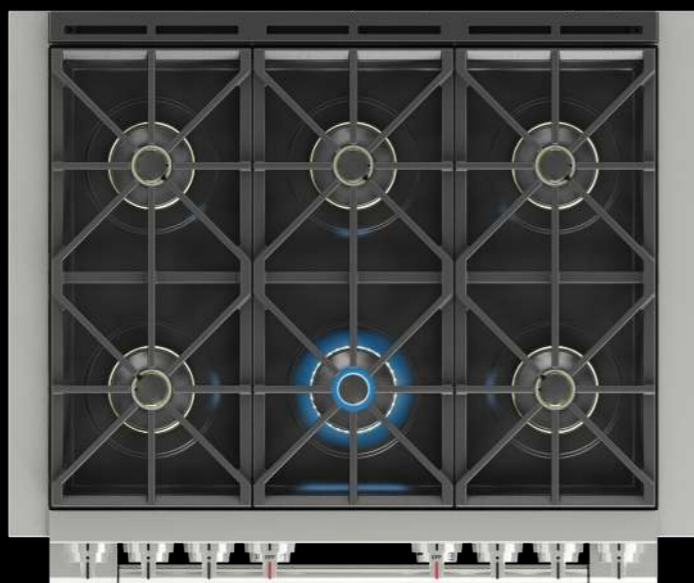

CRESCENDO is a special brass gas burner that ensures powerful and flexible heat distribution, making it suitable for any pan size and meeting any culinary needs.



**STRONG**

1

At the peak of its 20,000 BTU capability, meat is seared to produce a crust worthy of your favorite chef. Large pots quickly recover to a rigorous boil, and no culinary conquest seems unattainable. All burner rings engage to produce the most powerful flame for cooking.



**MEDIUM/STRONG**

2

Perfect al dente pasta is a snap. Progressive control of the burner ensures maximum heat distribution without excessive flame for an even and moderate boil.



**MEDIUM**

3

Creamy risotto and smooth custards come to life as the burner rings combine to provide enough heat to encourage the cooking but discourage scorching.



**MEDIUM/LOW**

4

Simmer, poach, or braise your way to a tender sauce, soup or stew. Flame curls around the diffuser cap to barely brush the base of the cooking vessel with perfect control for extended periods of low heat cooking.



**LOW**

5

Melt butter, temper chocolate, or gently coax the flavor from savory vegetables, this lowest setting is achieved by the flame from the simmer burner rolling gently under the diffuser cap to radiate whisper soft heat.

**FULGOR**  
MILANO

# 48 DUAL FUEL

## SOFIA PROFESSIONAL

SOFIA 48 DUAL FUEL is an example of FULGOR MILANO's excellence. It is a combination of Italian style, design, and accuracy. Since its beginnings, SOFIA 48 has been an international style icon thanks to its dimensions, and functionality. Moreover, it is flexible and enhances the creativity of professional chefs.



# 48 SOFIA PROFESSIONAL

## THE BEST PERFORMANCE

### UNRIVALLED WORKMANSHIP

Italy's proverbial workmanship in producing and processing steel ensures kitchens made with the utmost attention to detail, outstanding finishes, and excellent component assembly.

### COOL-TOUCH DOOR

The four heat-reflecting door glass panes are an efficient safety barrier as they maintain the heat inside the oven cavity even during the pyrolytic self-cleaning process (460 °C).

### ACCESSORY OVEN

This smaller multi-function and self-cleaning oven adds efficiency and flexibility to a SOFIA kitchen. It is fitted with telescopic racks, a ventilation system, and a soft closing door.

### CAST IRON GRATES

The professional continuous cast iron grates allows users to move the pans from one burner to another easily. The cast iron rear chimney perfectly blends in with the racks, allowing for ventilation.

### BRASS BURNERS

SOFIA 48" features six cooking zones (besides the Teppanyaki grill), each with CRESCENDO brass burners with five power levels. These burners have a double ring and combine power with even heat distribution, allowing optimal results using small and large pans.

### MAIN OVEN

The CREATIVE technology embedded in the main oven allows users to program specific functions and predefined recipes with the utmost flexibility. The Pizza Pizzeria 350° function bakes pizzas in 3 minutes, like our favourite pizzeria's wood-burning oven. The telescopic rack allows users to remove the trays easily. The pyrolytic function self-cleans oven: heat power against dirt. The door is always cool, thanks to its four heat-reflecting glass panels.

### SOFT-CLOSING DOOR

The oven's door is fitted with a SOFT CLOSING system that slows down the closing movement.

**FULGOR**  
MILANO

# 48 SOFIA PROFESSIONAL

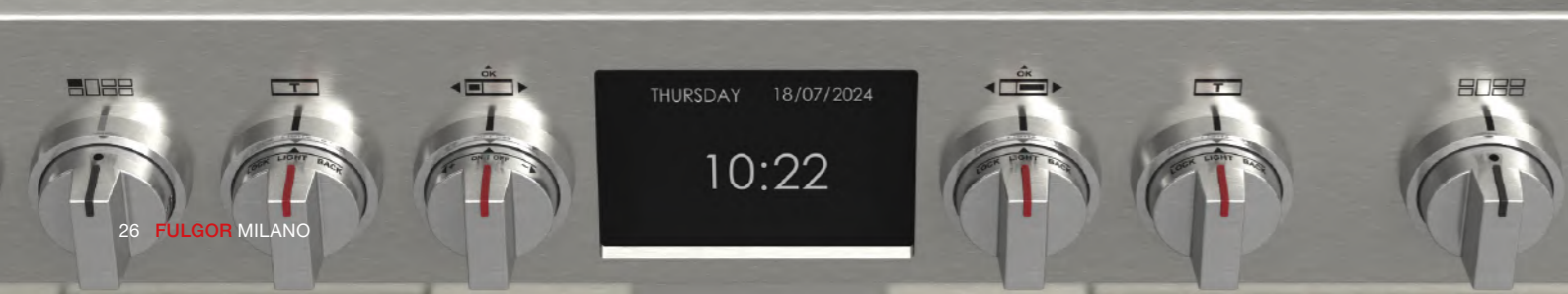
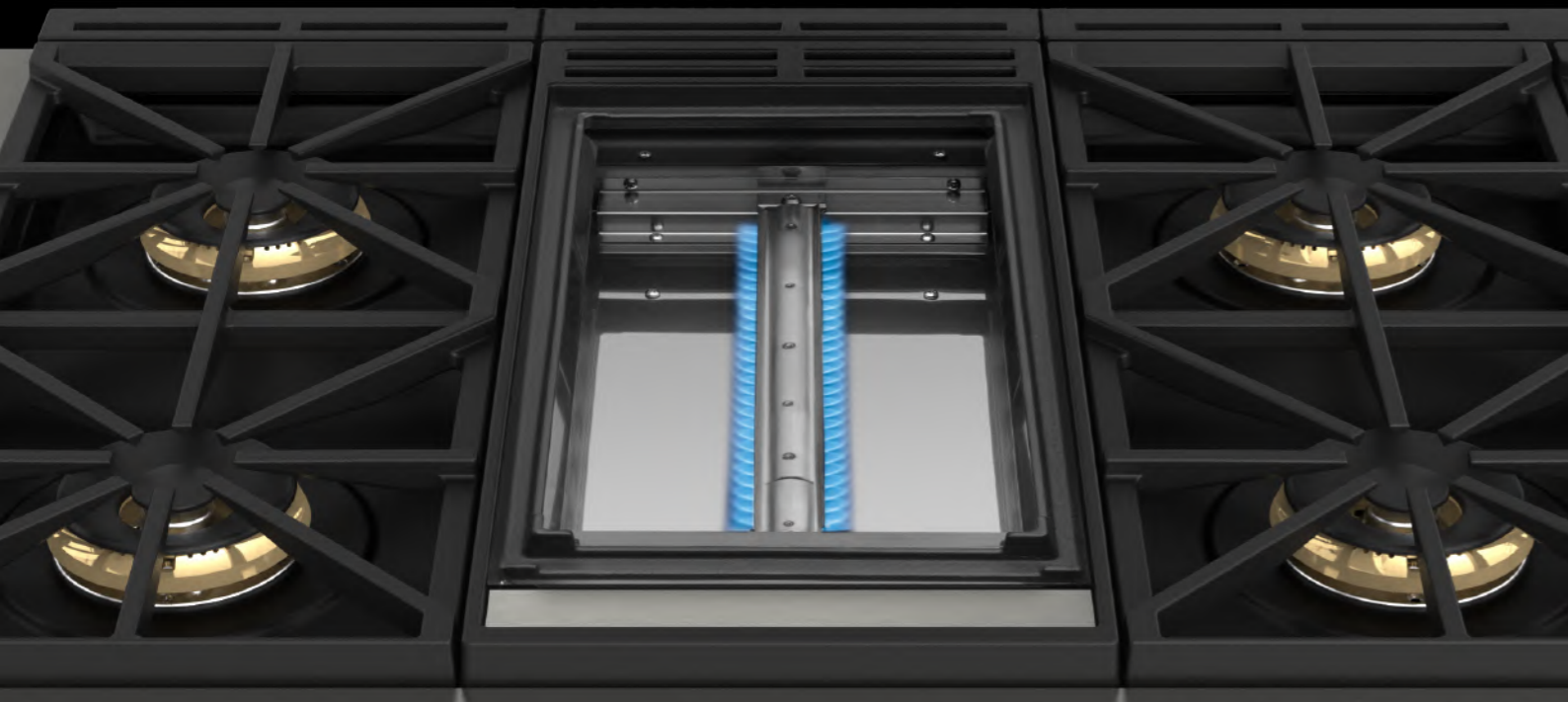
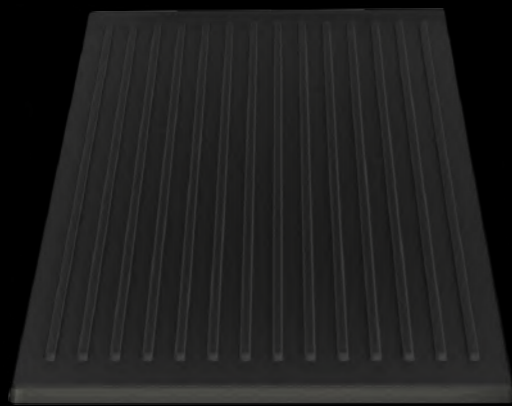

## GRILL | TEPPANYAKI

SOFIA 48 ensures the highest performance and versatility. Besides the CRESCENDO brass burners, it is equipped with a double-sided cast iron griddle. One side has special grooves for an authentic barbecue effect. The other side is a smooth griddle surface, ideal for Teppanyaki, a traditional Japanese cooking method known as one of the most healthy. Alternatively, the Teppanyaki griddle (tri-laminated with a stainless steel surface for even heat distribution) can be purchased separately. This cooking method enhances the taste of your preparations, maintaining their nutritional and organoleptic properties.

The special tubular aluminium burner distributes the flame evenly across the griddle surface, always ensuring optimal performance.

Therefore, the cooking method becomes a personal and exclusive cooking experience.

**FULGOR**  
MILANO

# 36 DUAL FUEL | GAS SOFIA PROFESSIONAL

SOFIA is synonymous with Italian style, craftsmanship, and design. It is available in the Dual Fuel and All Gas versions. This product has become extremely popular worldwide because of its design and functionality. Moreover, it is flexible and enhances the creativity of professional chefs. SOFIA's iconic style combines minimalist design with timeless classic lines, fitting harmoniously into the best international kitchens.

## COOKING COOKTOP

Sofia 36" cooktop features a special matte black enamelled surface, ensuring high resistance and easy cleaning. The six 5-in-1 CRESCENDO burners are the cooktop's core and are made of double-ring brass elements. These burners perfectly combine power and even heat distribution, for excellent results with both large and small pans. The professional continuous cast iron grates allow users to move the pans from one burner to another easily. The cast iron rear chimney perfectly blends in with the cooktop grates, allowing for ventilation.

## MULTIFUNCTION OVEN

SOFIA 36" professional oven features a 161 Liters cavity and a dual convection system to ensure perfect and homogeneous results. Moreover, the oven comes with professional racks and telescopic rails (fully removable). The pyrolytic self-cleaning function (Dual Fuel version) uses heat against dirt; whereas the four heat-reflecting door glass panes are an efficient safety barrier as they maintain the heat inside the oven cavity. The oven's door is fitted with a SOFT CLOSING system that slows the closing movement.





**Pro Multifunction 48"**

FSRC 4807 2P MK 2F X/2



- Electronic multifunction ovens
- Pizza Pizzeria 350 °C function
- AirFry (oven-frying) function
- Pyrolytic self-cleaning ovens
- Fast pre-heat function
- Main oven with dual convection
- Ventilated accessory oven
- Meat Probe
- Cool touch soft-close door
- Creative Digital Control with knobs
- INOX finish reversible plate cover
- Metal knobs with stainless steel finish
- Professional cast iron grates
- Pro Heavy Duty Enamelled Ribbon Plate / Griddle
- Matte black enamelled bowl
- 6 Crescendo Dual Gas Burners
- 1 Teppanyaki tubular burner
- NG or LPG supply

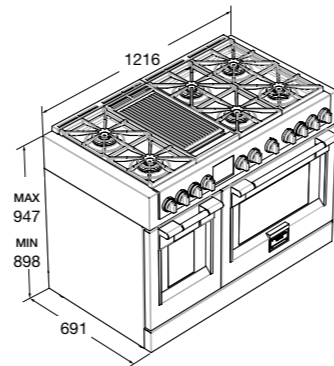

**Features**

SOFIA PRO 48 DUAL FUEL represents the excellence of FULGOR MILANO, it is synonymous with Italian style, mastery in product development and accuracy in workmanship. Thanks to the cooktop equipped with 6 Crescendo Dual brass gas burners, the reversible griddle featuring grills or TeppanYaki, and the two high-performance pyrolytic multifunction ovens, this version proves to be a flexible tool, capable of enhancing the creative aptitudes of kitchen professionals. The standard accessories of the main oven include a fully extractable telescopic rack, two flat racks, a MEAT probe, pizza set (round rack, peel and pizza stone), enameled tray with anti-splash and tray for AirFry. The support oven has a fully extractable telescopic rack, two flat racks and a stainless-steel tray for AirFry.

Accessories on request  
Technical data

page 302  
page 317



STAINLESS STEEL  
FSRC 4807 2P MK 2F X/2  
EAN 8019801022649

MATTE BLACK  
FSRC 4807 2P MK 2F MBK/2  
EAN 8019801022656



**Pro Multifunction 36"**

FSRC 3606 P MG MK 2F X



- Professional Digit Control
- Pizza Pizzeria 350 °C function
- AirFry (oven-frying) function
- Metal knobs with stainless steel finish
- 6 Crescendo Dual Burners
- Matte black enamelled bowl
- Professional cast iron grates
- NG or LPG supply
- Pyrolytic Multifunction Oven
- Fast Pre-Heat BOOSTER
- Interior dual convection

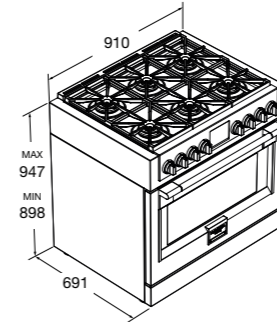

**Features**

SOFIA PRO 36" MULTIFUNCTION is synonymous with Italian style, masterful design and accuracy in steel processing. The professional cooktop is equipped with 6 flexible gas burners (Crescendo Dual brass burners), sturdy continuous cast iron pan supports and bowl coated with special matt black enamel which guarantees durability and easy cleaning. The 36" pyrolytic multifunction oven is the largest currently produced by Fulgor Milano. The standard accessories of the oven include a fully extractable telescopic rack, a meat probe, two flat racks, a pizza set (round rack, peel and pizza stone), enameled tray with anti-splash and tray for AirFry.

Accessories on request  
Technical data

page 302  
page 318



STAINLESS STEEL  
FSRC 3606 P MG MK 2F X  
EAN 8019801031870

MATTE BLACK  
FSRC 3606 P MG MK 2F MBK  
EAN 8019801031900



**Pro Gas 36"**

FSRC 3606 GG ED 2F X



- Professional Digit Control
- Metal knobs with stainless steel finish
- 6 Crescendo Dual Burners
- Matte black enamelled bowl
- Professional cast iron grates
- NG or LPG supply
- Gas-powered oven (NG or LPG)
- Interior dual convection
- Cool touch soft-close door
- Telescopic rack

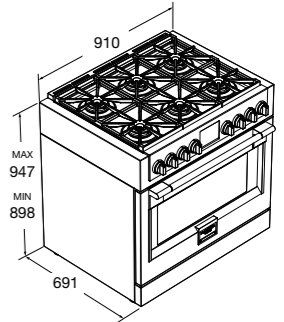

**Features**

SOFIA 36" PRO GAS is designed for those who appreciate the typical cooking characteristics of a gas oven. Like the other models, this version is characterized by an iconic style recognized all over the world. The professional cooktop is equipped with 6 flexible burners gas oven (Crescendo Dual brass burners), sturdy continuous cast iron grates and bowl coated with special matt black enamel, which guarantees durability and easy cleaning. The oven is the largest gas oven in terms of size and capacity (161 liters) currently produced by Fulgor Milano. The standard equipment of the oven includes a fully extractable telescopic rack, two flat racks and an enameled tray with anti-splash.

Accessories on request  
Technical data

page 302  
page 318



STAINLESS STEEL  
FSRC 3606 GG ED 2F X  
EAN 8019801017263

MATTE BLACK  
FSRC 3606 GG ED 2F MBK  
EAN 8019801031931

**FULGOR**  
MILANO

## SOFIA PROFESSIONAL OVEN



The Professional product line dedicated to built-in appliances includes the SOFIA 30" Pyrolytic Multifunction oven. Fulgor Milano provides the possibility to arrange products from the same family, like the steam oven, microwave oven and warming drawer, on the same column to meet the needs of the most demanding clients. The various Professional built-in product combinations allow for extraordinary aesthetic results.



### Piro Oven 30"

FSO 300 P MK 2F X



- Stainless steel finish
- Pizza Pizzeria 350 °C function
- AirFry (oven-frying) function
- Digital timer and steel knobs
- 18 cooking functions
- Pyrolytic self-cleaning oven
- Fast Pre-Heat BOOSTER
- Interior dual convection
- Cool touch soft-close door
- Telescopic rack
- Energy Class A

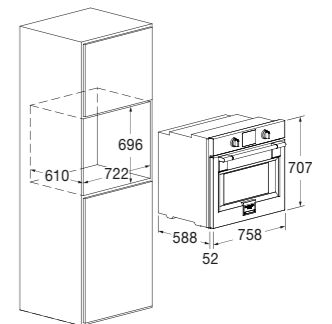

### Features

This 30" pyrolytic oven features a great structure, functional and aesthetic qualities that characterize the products of the Sofia Professional series. In addition to the classic cooking modes, there are a series of important technical features such as: double internal convection, "cool" door with 4 glasses, door soft close mechanism and self-cleaning function (Pyrolysis). The standard accessories of the oven include a fully extractable telescopic rack, a meat probe, two flat racks, a pizza set (round rack, peel and pizza stone), enameled tray with anti-splash and tray for AirFry.

Accessories on request  
Technical data

page 302  
page 319



STAINLESS STEEL  
FSO 300 P MK 2F X  
EAN 8019801031948



**FULGOR**  
MILANO

# 30 SPECIAL OVENS

## MICROWAVE

With Fulgor Milano's Combi Microwave Oven, chefs can enjoy all the advantages of combined cooking. They can grill or choose one of the many combined cooking functions to speed up the cooking. It perfectly combines with the other Professional built-in home appliances.



## STEAM

Practical and versatile oven that uses steam heat to cook food healthily and maintain all its organoleptic properties. This oven can alternate steam cooking with the thermo-convection mode. Once the water boiler has heated the water, the steam is sprayed inside the cooking chamber.



**Combi 30" Steam Oven**

FPCSO 300 TEM X



**Combi 30" Microwave Oven**

FPCMO 300 TEM X



- Stainless steel finish
- 12 cooking functions
- AirFry (oven-frying) function
- Steam recovery cycle
- Combined cooking mode
- CLEAN assisted cleaning cycle
- Stainless steel interior

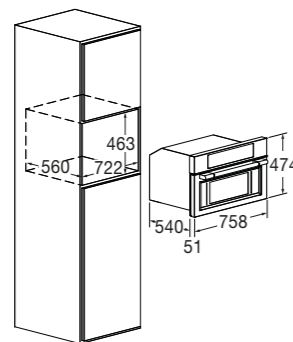

- Stainless steel finish
- 10 cooking functions
- AirFry (oven-frying) function
- Microwave modes (6 levels)
- Assisted ventilation mode
- Combined cooking mode
- Microwave and grill mode
- Defrosting
- Stainless steel interior

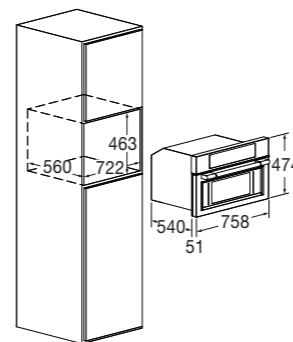

**Features**

The Professional product line, dedicated to the built-in, offers to the most demanding customers the possibility of placing products in columns, combining, for example, the products of the same line; such as, the 30" oven, steam oven, microwave and warming drawer, allowing thus obtaining extraordinary aesthetic and cooking results. The steam oven has 12 cooking functions, among which we mention, for example, the combined cooking capacity, combined cooking modes and AirFry cooking. The digital control allows the use of predefined cooking modes as well as the ability to create new recipes. The standard accessories include a meat probe, a perforated tray with lid, a stainless steel support for perforated tray, a stainless steel tray, a flat grill rack and a water tank.

Accessories on request page 306  
 Technical data page 320

**Features**

The Professional product line, dedicated to built-in, offers to the most demanding customers the possibility of placing products in columns, for example by combining the 30" oven with products from the same line such as the steam oven, microwave oven and warming drawer, allowing thus obtaining extraordinary aesthetic and cooking results. The microwave oven has 10 cooking functions, among which we mention for example the combined cooking capacity, microwave, grilling modes and AirFry cooking. The digital control allows the use of programs predefined cooking modes as well as the possibility of creating new recipes. The standard accessories include a glass turntable plate, a stainless steel tray, a flat grill rack and a round grill rack.

Accessories on request page 307  
 Technical data page 320



STAINLESS STEEL  
 FPCSO 300 TEM X  
 EAN 8019801031153



STAINLESS STEEL  
 FPCMO 300 TEM X  
 EAN 8019801031160



**FULGOR**  
 MILANO

**FULGOR**  
MILANO

PROFESSIONAL  
**30 COFFEE  
MACHINE**



The integrated coffee machine can be considered as a personal barista. It instantly grinds and automatically stores coffee beans while storing the coffee waste in the waste container. At the touch of a button, you can choose among 5 variants, from espresso to cappuccino, just like at the bar. Besides being easy to use, this Italian professional coffee machine perfectly complements your Fulgor Milano kitchen appliances. The exclusive 30" KIT PRO (optional) perfectly combines with the other Professional built-in home appliances.

**PROFESSIONAL**



**30" coffee machine**

**FCM 4500 TF BK + F6PTK30BC**



- Deep Black finish
- 30 functions
- TFT touch control display
- Automatic programs
- Coffee bean container (200 g)
- Integrated and adjustable grinding
- Milk container
- Water container (1.8 l)
- Removable hot water dispenser
- Liquid collection container
- Five types of cup

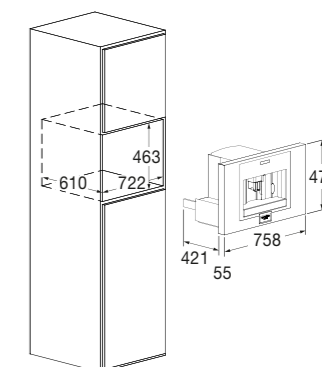

**Features**

The integrated coffee machine can be considered a personal barista. It allows the conservation of coffee beans, their instant grinding and the automatic storage of the grounds in the collection tray. Coffee like at the coffeeshop, with the possibility, with the simple touch of a button, of choosing 5 different coffee variations, passing from espresso to cappuccino. This professional quality machine, easy to use and made in Italy, is the perfect complement to your Fulgor Milano kitchen products. The exclusive PRO FRAME KIT (optional) allows perfect combination with the other built-in appliances of the Professional 30" series. The touch control and the digital display make the use of the coffee machine intuitive and immediate. There is the possibility of choose coffee quantity and intensity, from very light to extra strong. In addition to this, numerous drinks can be prepared thanks to the automatic cappuccino maker and the hot water dispensing for tea and herbal teas. For an optimal result, it is also possible to verify the water hardness. The system is equipped with stand-by to save electricity and an extensive safety system: light indicator for no water, no coffee, need for a cleaning cycle and replacement of the limescale filter. Access to the service compartments is through a practical opening. The badge with the Fulgor Milano logo can optionally be positioned as desired by the customer.

Accessories on request

Technical data

page 309

page 365



BLACK GLASS  
FCM 4500 TF BK  
EAN 8019801025077



PRO FRAME KIT  
F6PTK30BC  
EAN 8019801026265



## 30" warming drawer

FPWD 3024 X



- Stainless steel finish
- Handle opening
- Keep-warm function
- Defrosting
- Dough leavening
- Slow cooking up to 85 °C
- Dish pre-heating function
- Coffee cup pre-heating function
- Convection
- Internal light
- Soft closing

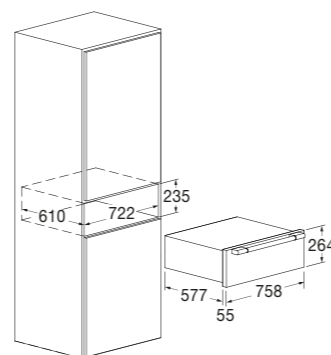

## Features

The warming drawer of the Professional line is made entirely of metal and is characterized by a front panel in stainless steel and handle of the Professional series. It has various functions including, for example: maintaining food temperature, defrosting, dough leavening, delicate cooking up to 85°C and dishes preheating. With generous internal dimensions (60 litres), the drawer is equipped with: adjustable control thermostat from 30°C to 85°C, non-slip rubber mat, internal lighting, soft closing (telescopic rails).

Technical data

page 321



STAINLESS STEEL  
FPWD 3024 X  
EAN 8019801031221

**FULGOR**  
MILANO

NEW

**FULGOR**  
MILANO

# PROFESSIONAL 48 RANGE TOP

Professional Range top: style and performance, elegance and efficiency. The combination of solid materials and cutting-edge technologies ensures an iconic design that is particularly versatile and functional. Distinctive elements of this striking Range top include the robustness of the stainless steel structure, the sleekness of the induction system, and the functionality of the knob controls. The Range top features seven zones, including a flexible BRIDGE zone and a high-performance DUAL MAX POWER zone.





48" Induction Range Top

FSRT 4807 ID X



- Stainless Steel Aesthetic
- Metal knobs with INOX finish
- 7 cooking zones, including 1 Dual Max Power zone Ø 28 cm
- Glass-ceramic surface
- Pan detection sensor
- BOOST Fast preheating
- Bridge Zone
- Child Safety Function

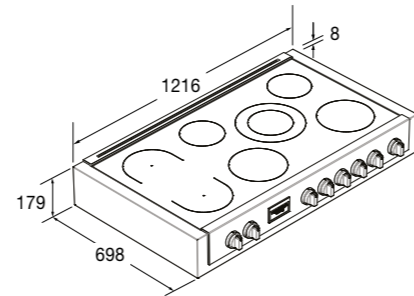

Features

The Range Top by Fulgor Milano features the iconic design of the Sofia Professional series, combining elegance and performance in a single solution. Designed for built-in installation, it blends durable materials with cutting-edge technologies. The cooktop is equipped with seven powerful induction zones, including a flexible BRIDGE and an efficient DUAL MAX POWER zone with a 28 cm diameter. The black ceramic glass surface with a scratch-resistant finish integrates an under-glass control display, while the practical knobs allow for immediate control of the cooking zones.

Accessories on request  
 Technical data

page 302  
 page 322



STAINLESS STEEL  
 FSRT 4807 ID X  
 EAN 8019801035021



36" Induction Range Top

FSRT 3605 ID X



- Stainless Steel Aesthetic
- Metal knobs with INOX finish
- 5 cooking zones, including 1 Dual Max Power zone Ø 28 cm
- Glass-ceramic surface
- Pan detection sensor
- BOOST Fast preheating
- Child Safety Function

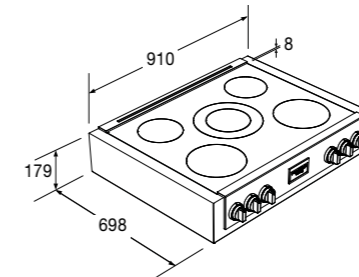

Features

The Range Top by Fulgor Milano features the iconic design of the Sofia Professional series, combining elegance and performance in a single solution. Designed for built-in installation, it blends durable materials with cutting-edge technologies. The cooktop is equipped with five powerful induction zones, including an efficient DUAL MAX POWER zone with a 28 cm diameter. The black ceramic glass surface with a scratch-resistant finish integrates an under-glass control display, while the practical knobs allow for immediate control of the cooking zones.

Accessories on request  
 Technical data

page 302  
 page 323



STAINLESS STEEL  
 FSRT 3605 ID X  
 EAN 8019801035007



30" Induction Range Top

FSRT 3004 ID X



- Stainless Steel Aesthetic
- Metal knobs with INOX finish
- 4 Cooking Zones
- Glass-ceramic surface
- Pan detection sensor
- BOOST Fast preheating
- Child Safety Function

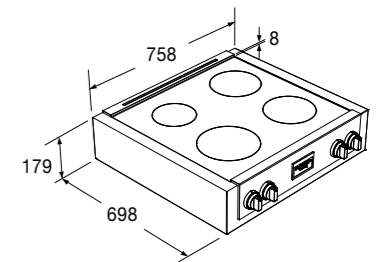

Features

The Range Top by Fulgor Milano features the iconic design of the Sofia Professional series, combining elegance and performance in a single solution. Designed for built-in installation, it blends high-quality materials with cutting-edge technologies. The cooktop is equipped with four powerful induction zones, designed to ensure high performance and maximum efficiency in the kitchen. The black ceramic glass surface with a scratch-resistant finish integrates an under-glass control display, while the practical knobs allow for immediate control of the cooking zones.

Accessories on request  
 Technical data

page 302  
 page 324



STAINLESS STEEL  
 FSRT 3004 ID X  
 EAN 8019801035014

NEW

**FULGOR**  
MILANO

# PROFESSIONAL 48 RANGE TOP



The 48" Fulgor Milano Range Top embodies the iconic elegance of the Sofia Professional collection, combining refined design with high-performance cooking. Designed for built-in installation, it features solid cast iron grates and six powerful Crescendo burners, delivering exceptional precision and complete creative freedom in the kitchen. The reversible cast iron griddle adds outstanding versatility: one side is designed with special grooves to create authentic barbecue-style grill marks, while the other offers a teppanyaki surface, ideal for exploring traditional Japanese cooking, widely regarded as one of the healthiest culinary techniques.

## PROFESSIONAL

HOB



### 48" Gas Range Top

FSRT 4807 G X



- Stainless steel finish
- NG or LPG supply
- 6 Crescendo Dual Burners
- 1 Tubular Teppanyaki burner
- Matte black enamelled bowl
- Professional cast iron grates
- Steel knobs

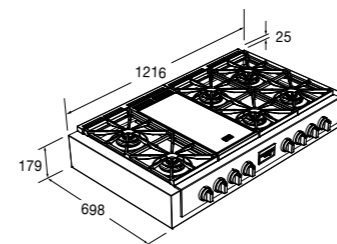

### Features

The Range Top by Fulgor Milano features the iconic design of the Sofia Professional series, combining elegance and performance in a single solution. Designed for built-in installation, it merges durable materials with cutting-edge technologies. The cooktop features sturdy cast iron grates, a stylish surface with a special matte black finish, and practical knobs that allow precise control of the six powerful Crescendo burners. The cast iron griddle comes with a reversible surface: one side has special grooves to guarantee a perfect grilling, while the other side offers a teppanyaki surface, ideal for experimenting the refined traditional Japanese cooking technique. The cooktop is also equipped with a Gas-Stop Safety System that automatically shuts off the gas flow when necessary, providing greater tranquility during its use.

Accessories on request

page 302

Technical data

page 325



STAINLESS STEEL  
FSRT 4807 G X  
EAN 8019801035083



### 36" Gas Range Top

FSRT 3606 G X



- Stainless steel finish
- NG or LPG supply
- 6 Crescendo Burners
- Matte black enamelled bowl
- Professional cast iron grates
- Steel knobs

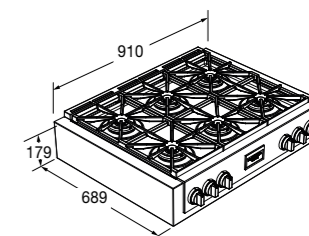

### Features

The Range Top by Fulgor Milano has inherited the iconic design of the Sofia Professional series. For those who want a built-in installation, this product (combined with the professional built-in oven) features a combination of solid materials and cutting-edge technologies, ensuring versatile and functional solutions. Distinctive elements with a sure visual effect are the sturdiness of the stainless-steel structure (handcrafted), the continuous grates, bowl with a special matt black enameled finish and the metal knobs. The high-quality Crescendo Dual gas burners adjustable from 450 to 4500 W (NG), offer infinite adjustment possibilities in all six cooking zones. The cooktop is naturally equipped with a Gas-Stop safety devices.

Accessories on request

page 302

Technical data

page 326



STAINLESS STEEL  
FSRT 3606 G X  
EAN 8019801017294

**FULGOR**  
MILANO

# PROFESSIONAL EXTRACTION

48 | 36



## FEATURES

### TWIN MOTOR

Twin aluminum body electric motor allow for suitable extraction even under intensive use.

### PROFESSIONAL FILTERS

The stainless steel labyrinth filters improve ventilation and grease collection. Moreover, thanks to the oil drip trays, they are the best solution for maintaining and cleaning the product.

### SOFT-TOUCH CONTROLS

The user-friendly controls ensure operation precision and function coordination.

### LED LIGHTING

The two high-efficiency LED side bars provide optimal illumination to the cooking area.



The matching wall-mounted hood (available in two sizes) was designed to keep the kitchen free from smoke, food residues, and excess heat. Two powerful electric motors combined with stainless steel labyrinth filters silently extract all odours. The LED side bars light up the cooking area.



**48" wall-mounted hood**

FPRHD 482 TC X



- Soft touch controls
- AISI 430 stainless steel finish
- 2 motors
- Suction power 1,450 m³/h
- 4 extraction levels
- Power off timer
- Sound power from 48 to 75 dBA
- 2 LED bars
- Stainless steel labyrinth grease filter + filter saturation warning light
- Oil drip tray + non-return valve
- Energy Class A

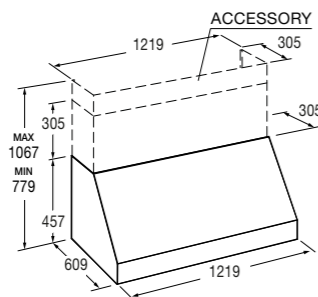

**Features**

The 48" wall hood comes in two different finishes: stainless steel and matt black. Designed to keep the kitchen environment free from smoke, steam and excess heat, it is equipped with two powerful motors which, in combination with the stainless-steel grease filters (Baffle) allow odors to be expelled in silence. With the HP activated carbon filter accessory, the hood can work in filtering mode. The LED lighting guaranteed by two side bars illuminates the cooking surface area.

On request:

- 48" stainless steel chimney kit
- 48" matte black chimney kit
- HP activated carbon filter

Accessories on request page 303  
 Technical data page 327



STAINLESS STEEL  
 FPRHD 482 TC X  
 EAN 8019801022038



MATTE BLACK  
 FPRHD 482 TC MBK  
 EAN 8019801022076



**36" wall-mounted hood**

FPRHD 362 TC X



- Soft touch controls
- AISI 430 stainless steel finish
- 2 motors
- Suction power 1,450 m³/h
- 4 extraction levels
- Power off timer
- Sound power from 48 to 75 dBA
- 2 LED bars
- Stainless steel labyrinth grease filter + filter saturation warning light
- Oil drip tray + non-return valve
- Energy Class A

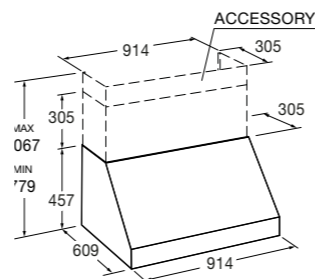

**Features**

The 36" wall hood comes in two different finishes: stainless steel and matt black. Designed to keep the kitchen environment free from smoke, steam and excess heat, it is equipped with two powerful motors which, in combination with the stainless-steel grease filters (Baffle) allow silent operation. With the HP activated carbon filter accessory the hood can work in filtering mode. The LED lighting guaranteed by two side bars illuminates the cooking surface area.

On request:

- 36" stainless steel chimney kit
- 36" matte black chimney kit
- HP activated carbon filter

Accessories on request page 303  
 Technical data page 327



STAINLESS STEEL  
 FPRHD 362 TC X  
 EAN 8019801022021



MATTE BLACK  
 FPRHD 362 TC MBK  
 EAN 8019801022069

**FULGOR**  
 MILANO



FULGOR  
MILANO

BBQ

BBQ



**FULGOR**  
MILANO

# BBQ

## COOKING OUTDOORS

Thanks to the FULGOR BBQ range, you can grill, cook, and roast meat, fish, and vegetables in your garden, by the poolside or on the terrace. FULGOR barbecues ensure versatility and high performance.

## MAINTENANCE AND CLEANING

Cleaning the barbecue has never been easier, thanks to the stainless steel finish and cooking surfaces. Stainless steel is a highly hygienic and durable material. Moreover, it does not alter food flavours. Every component is interlocked in the structure to facilitate their removal. Therefore, the grill racks and griddle can be easily removed and washed.

## TEPPANYAKI

The stainless steel griddle is suitable for Teppanyaki, a Japanese cooking style considered one of the most healthy methods because it maintains nutritional and organoleptic properties. The griddle and grill racks can be positioned depending on the cooking needs. However, users must remember to reposition the gas burner baffles provided for the grill racks.

## GRILLING

The oversized stainless steel grill racks supplied with the barbecue are perfect for cooking generous portions of meat or fish. They are also available in cast iron (to be purchased separately).

## LIDS

FULGOR BBQ can be completed with a lid (accessory) available in two versions (high or low), depending on your preference.

The high lid has two walls and a thermometer to control the cavity's temperature when the BBQ is closed. The low lid is designed to protect the BBQ's surface from harsh weather conditions. Both these lids are fitted with a Professional handle.

## SAFETY

No electric connection, just a battery to start the burners, which are equipped with a detection and supply blocking valve.

## METAL KNOBS

FULGOR Professional metal knobs are large to ensure an ergonomic grip.

# BBQ

## MATTE BLACK FINISH

The matte black finish provides a unique style to the barbecue and lids.

## ERGONOMIC CONTROLS

The steel handle and knobs are particularly resistant and easy to use.

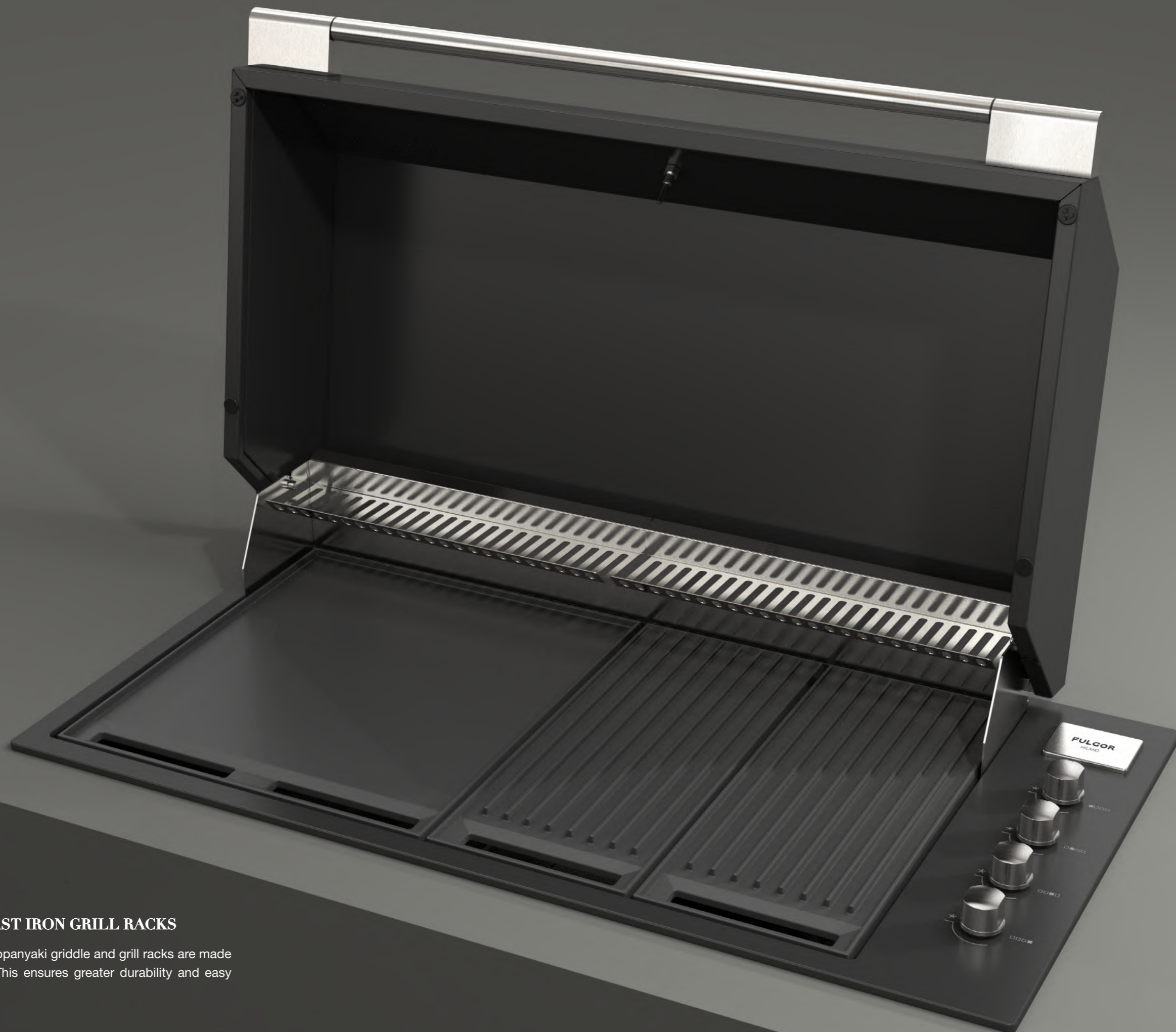

## TEPPANYAKI GRIDDLE AND CAST IRON GRILL RACKS

In the elegant matte black version, the Teppanyaki griddle and grill racks are made of highly resistant enamelled cast iron. This ensures greater durability and easy cleaning.

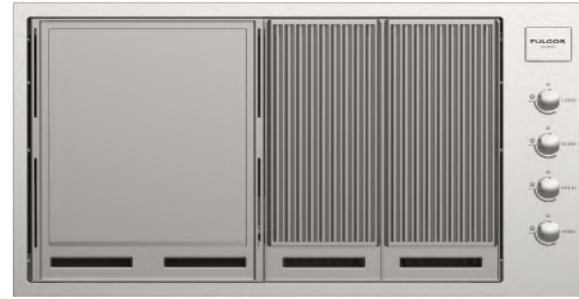

## Barbecue 1000

FOBQ 1000 G X



- AISI 316 stainless steel
- NG or LPG supply
- 4 in-line tubular gas burners
- Metal knobs
- Battery-operated electronic ignition
- Stainless steel Teppanyaki griddle
- 2 stainless steel grill racks
- Removable drip tray

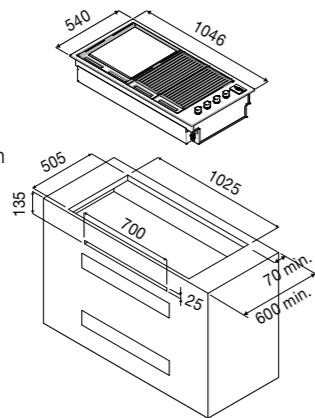

### Features

The Fulgor Milano built-in barbecue in AISI 316 stainless steel has 4 tubular gas burners, with a total power of approximately 15,2 kW. Special gas conversion nozzles are supplied as standard to allow the use with both NG and LPG. The in-line arrangement of the burners allows you to separate the cooking zones and also allowing the use of different temperatures. The BBQ is equipped with Gas-Stop safety devices. Among the accessories on request, in addition to the different types of grates, two different lid models are available (high and low).

Accessories on request page 304  
 Technical data page 328



STAINLESS STEEL  
 FOBQ 1000 G X  
 EAN 8019801021857



## Barbecue 1000

FOBQ 1000 G MBK



- Matte black enameled steel
- NG or LPG supply
- 4 in-line tubular gas burners
- Metal knobs
- Battery-operated electronic ignition
- Cast-iron Teppanyaki griddle
- 2 cast-iron grill racks
- Removable drip tray

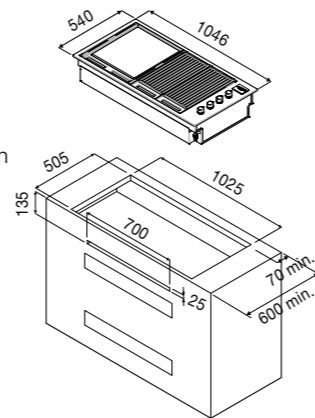

### Features

The Fulgor Milano built-in barbecue with matt black enameled steel finish is equipped as standard with sturdy cast iron grates and has 4 tubular gas burners, with a total power of approximately 15,2 kW. Special gas conversion nozzles are supplied as standard to allow the use with both NG and LPG. The in-line arrangement of the burners allows you to separate the cooking zones and also allowing the use of different temperatures. The BBQ is equipped with Gas-Stop safety devices. Among the accessories on request, in addition to the different types of grates, two different lid models are available (high and low).

Accessories on request page 304  
 Technical data page 329



MATTE BLACK  
 FOBQ 1000 G MBK  
 EAN 8019801021888



## High lid 1000

FOBQ HL 1000 X



- AISI 316 stainless steel finish
- External thermometer
- Inner temperature control
- Steel tubular knob

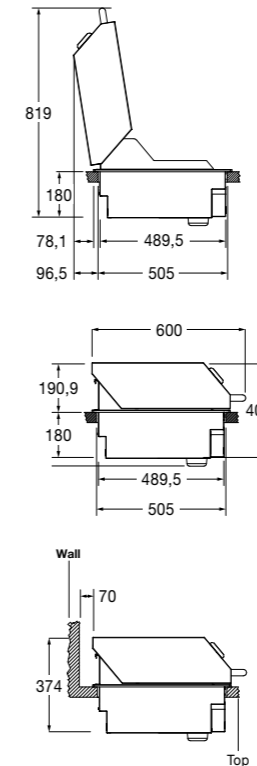

NOTE: In the image, other than seeing the lid also the BBQ is shown (sold separately)

Technical data Stainless Steel page 228  
 Technical data Matte Black page 329



STAINLESS STEEL  
 FOBQ HL 1000 X  
 EAN 8019801021864



MATTE BLACK  
 FOBQ HL 1000 MBK  
 EAN 8019801021895



## Low lid 1000

FOBQ LL 1000 X



- AISI 316 stainless steel finish
- Steel flat knob

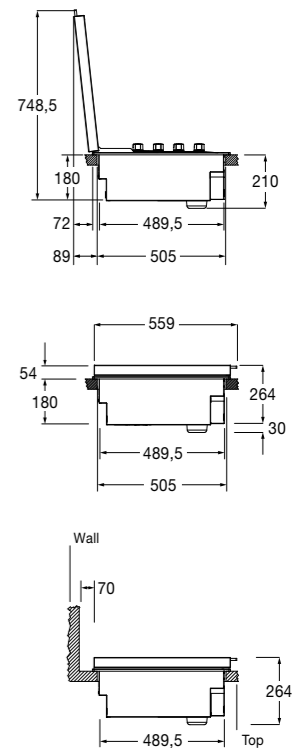

NOTE: In the image, other than seeing the lid also the BBQ is shown (sold separately)

Technical data Stainless Steel page 228  
 Technical data Matte Black page 329



STAINLESS STEEL  
 FOBQ LL 1000 X  
 EAN 8019801021871



MATTE BLACK  
 FOBQ LL 1000 MBK  
 EAN 8019801021901

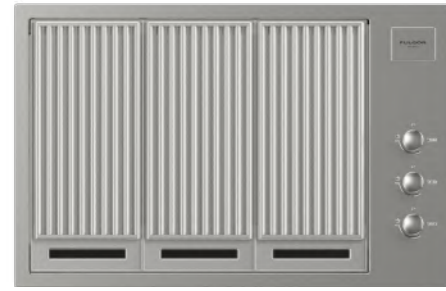

## Barbecue 800

FOBQ 803 G X



- AISI 316 stainless steel
- NG or LPG supply
- 3 in-line tubular gas burners
- Metal knobs
- Battery-operated electronic ignition
- 3 stainless steel grill racks
- Removable drip tray

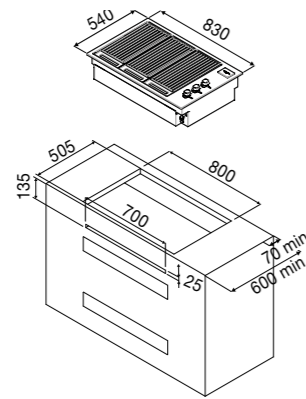

### Features

The Fulgor Milano built-in barbecue in AISI 316 stainless steel has 3 tubular gas burners, with a total power of approximately 11,4 kW. Special gas conversion nozzles are supplied as standard to allow the use with both NG and LPG. The in-line arrangement of the burners allows you to separate the cooking zones and also allowing the use of different temperatures. The BBQ is equipped with Gas-Stop safety devices. Among the accessories on request, in addition to a TeppanYaki griddle and the different types of grates, two different lid models are available (high and low).

Accessories on request page 304  
 Technical data page 330



STAINLESS STEEL  
 FOBQ 803 G X  
 EAN 8019801027392



## Barbecue 800

FOBQ 803 G MBK



- Black matte enamelled steel
- NG or LPG supply
- 3 in-line tubular gas burners
- Metal knobs
- Battery-operated electronic ignition
- 3 cast-iron grill racks
- Removable drip tray

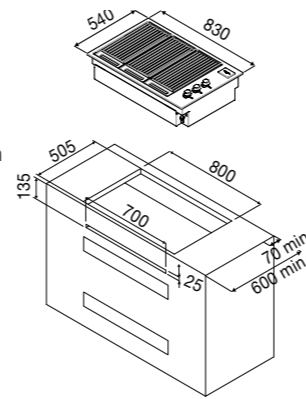

### Features

The Fulgor Milano built-in barbecue with matt black enameled steel finish is equipped as standard with sturdy cast iron grates and has 3 tubular gas burners, with a total power of approximately 11,4 kW. Special gas conversion nozzles are supplied as standard to allow the use with both NG and LPG. The in-line arrangement of the burners allows you to separate the cooking zones and also allowing the use of different temperatures. The BBQ is equipped with Gas-Stop safety devices. Among the accessories on request, in addition to a TeppanYaki griddle and the different types of grates, two different lid models are available (high and low).

Accessories on request page 304  
 Technical data page 331



MATTE BLACK  
 FOBQ 803 G MBK  
 EAN 8019801031344



## High lid 800

FOBQ HL 800 X



- AISI 316 stainless steel finish
- External thermometer
- Inner temperature control
- Steel tubular knob

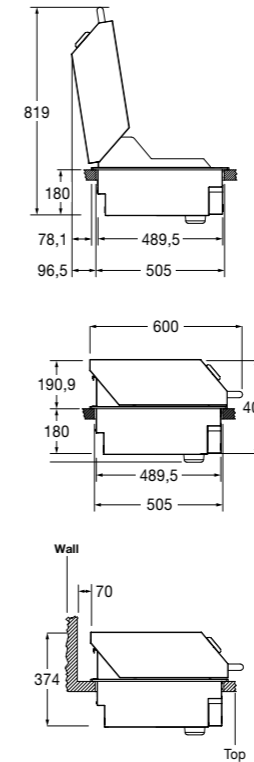

NOTE: In the image, other than seeing the lid also the BBQ is shown (sold separately)

Technical data Stainless Steel page 330  
 Technical data Matte Black page 331



STAINLESS STEEL  
 FOBQ HL 800 X  
 EAN 8019801027453



MATTE BLACK  
 FOBQ HL 800 MBK  
 EAN 8019801031269



## Low lid 800

FOBQ LL 800 X



- AISI 316 stainless steel finish
- Steel flat knob

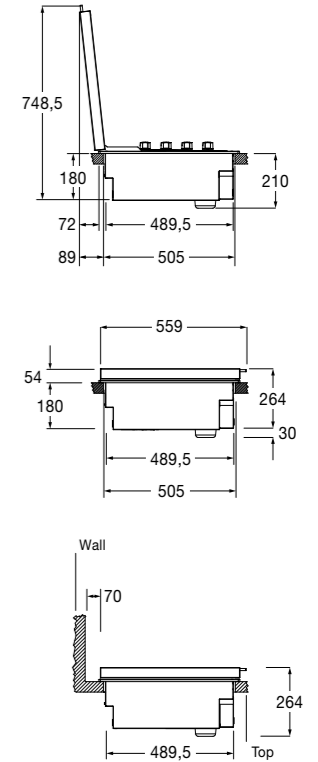

NOTE: In the image, other than seeing the lid also the BBQ is shown (sold separately)

Technical data Stainless Steel page 330  
 Technical data Matte Black page 331



STAINLESS STEEL  
 FOBQ LL 800 X  
 EAN 8019801027446



MATTE BLACK  
 FOBQ LL 800 MBK  
 EAN 8019801031962



## Barbecue 600

FOBQ 601 TY G X



- NG or LPG supply
- AISI 316 stainless steel finish
- 2 in-line tubular gas burners
- Metal knobs
- Battery-operated electronic ignition
- Stainless steel Teppanyaki griddle
- Removable drip tray

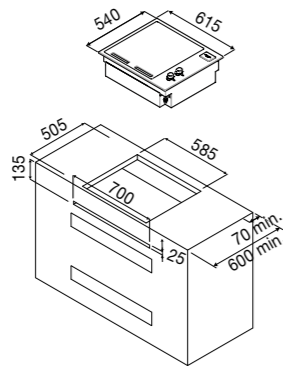

## Features

The Fulgor Milano built-in barbecue in AISI 316 stainless steel comes with Teppanyaki plate and has 2 tubular gas burners, with a total power of approximately 7,6 kW. Special gas conversion nozzles are supplied as standard to allow the use with both NG and LPG. The in-line arrangement of the burners allows you to separate the cooking zones and also allowing the use of different temperatures. The BBQ is equipped with Gas-Stop safety devices. Among the accessories on request, in addition to different types of grates, two different lid models are available (high and low).

Accessories on request page 304  
 Technical data page 330



STAINLESS STEEL  
 FOBQ 601 TY G X  
 EAN 8019801027415



## Barbecue 600

FOBQ 602 G X



- NG or LPG supply
- AISI 316 stainless steel finish
- 2 in-line tubular gas burners
- Metal knobs
- Battery-operated electronic ignition
- 2 stainless steel grates
- Removable drip tray

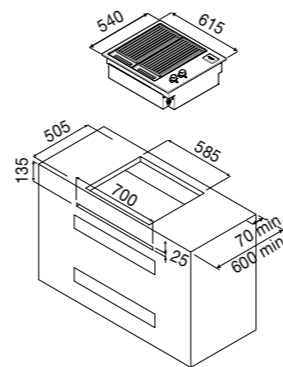

## Features

The Fulgor Milano built-in barbecue in AISI 316 stainless steel comes with two stainless steel grates and has 2 tubular gas burners, with a total power of approximately 7,6 kW. Special gas conversion nozzles are supplied as standard to allow the use with both NG and LPG. The in-line arrangement of the burners allows you to separate the cooking zones and also allowing the use of different temperatures. The BBQ is equipped with Gas-Stop safety devices. Among the accessories on request, in addition to Teppanyaki and different types of grates, two different lid models are available (high and low).

Accessories on request page 304  
 Technical data page 330



STAINLESS STEEL  
 FOBQ 602 G X  
 EAN 8019801027408



## High lid 600

FOBQ HL 600 X



- AISI 316 stainless steel finish
- External thermometer
- Inner temperature control
- Steel tubular knob

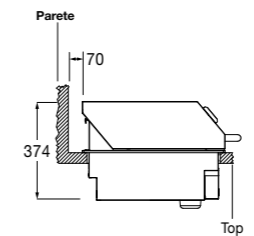
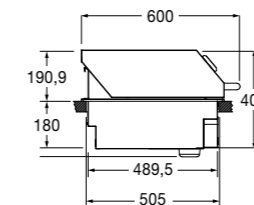
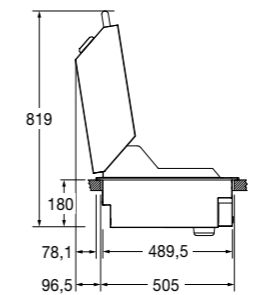

NOTE: In the image, other than seeing the lid also the BBQ is shown (sold separately)

Technical data page 330



STAINLESS STEEL  
 FOBQ HL 600 X  
 EAN 8019801027439



## Low lid 600

FOBQ LL 600 X



- AISI 316 stainless steel finish
- Steel flat knob

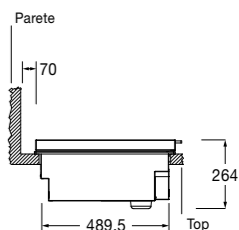
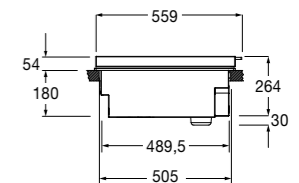
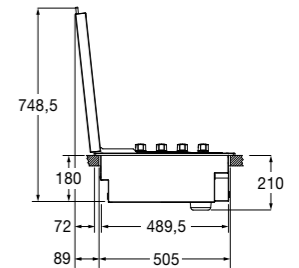

NOTE: In the image, other than seeing the lid also the BBQ is shown (sold separately)

Technical data page 330



STAINLESS STEEL  
 FOBQ LL 600 X  
 EAN 8019801027422

**FULGOR**  
MILANO

**WATER ASPIRES TO BECOME  
STEAM AND STEAM  
TO TURN WATER AGAIN**

(Marguerite Yourcenar)



CLUSTER

**ATMOS STEAM OVEN**

**FULGOR**  
MILANO

# CLUSTER COLLECTION

Deep Black and metal, black glass and stainless steel finish: the combination of materials in CLUSTER's distinguishing features creates a trendy appearance.

The original design of the handle and control panel makes the CLUSTER range unique and exclusive.

FULGOR  
MILANO

# CLUSTER MULTIFUNCTION OVENS

**FULGOR**  
MILANO



## PIZZA PIZZERIA 350°C

FULGOR MILANO's Piro Pizza oven is the first oven for household use that cooks several pizzas simultaneously in 3 minutes, like a traditional wood-burning oven. The result is a perfectly cooked pizza. The oven reaches a temperature of 350 °C, ensuring a steaming pizza for all diners.

Thanks to the Creative Extended control with dual keypad, selecting the appropriate cooking function will be a piece of cake. All you have to do is select the recipes on the display, and the oven will do the rest.

## COOL TOUCH - SOFT-CLOSE DOOR

The three heat-reflecting door glass panes are an efficient safety barrier as they isolate the heat inside the oven cavity even during the pyrolytic self-cleaning process.

Some ovens include fully removable telescopic rails to help you remove the trays easily.

60/75/90 Cluster ovens are fitted with a SOFT CLOSING door.

# CLUSTER ATMOS OVEN

## AUTO CONTROL PANEL OPENING

ATMOS, a premium product, presents an automatic control panel opening system. This system allows you to fill the water tank without opening the oven's door, dispersing heat. The large water tank is easy to reach, and is fitted with baffles to prevent water spillage. Thanks to a sensor system, you can check the water level in the tank from the control panel.

## SPECIAL BOILER

ATMOS has a special boiler with two power levels to reach the set temperature quickly and maintain it to increase, for the same amount of water, the cooking times.

## EASY CLEANING

The automatic descaling program (to be launched periodically) and the cleaning functions of the cavity and circuit place ATMOS as a TOP-range product.

## 100 X 100 STEAM

Thanks to the 100x100 steam function, you can steam cook your food, preserving its flavour and nutritional properties.

## PUFF OF STEAM

During fan or static cooking, once the temperature exceeds 100 °C, you can add a steam puff any time you want, thanks to the PUFF of STEAM function. This function is particularly suitable for cooking vegetables, fish, side dishes, and even fruit.

## ADJUSTABLE STEAM

Temperature increments are 1°C for all steam cooking and some special recipes up to 100°C, beyond which the increment is 5°C. This allows you to calibrate the right amount of steam for each recipe.



ATMOS is the latest addition to FULGOR MILANO's oven range. ATMOS is a steam oven with 24 cooking functions, ideal for complex and easy preparations. ATMOS is synonymous with versatility. For example, there's a cooking function for any preparation, which you can use with the peace of mind that only a product in energy class A++ can ensure. One oven for steam and traditional cooking.

ATMOS is available in the elegant aesthetics of the CLUSTER range and with the professional stainless steel finish of the PLANO range. Made with top-quality materials, taking care of the smallest details, this oven's structure is intended to last over time.

# CREACTIVE

## THE OPERATING SYSTEM FOR ASSISTED COOKING

### EXTENDED

Selecting the appropriate cooking function is now a piece of cake. All you have to do is select the recipes on the display, and the oven will do the rest. The CREAACTIVE EXTENDED operating system allows you to adapt preset recipes to your needs, varying the weight and cooking time. This system improves the overall performance, reduces energy consumption, and increases the number of cooking functions. Even safety is improved, thanks to the automatic control system that warns and prevents damage.

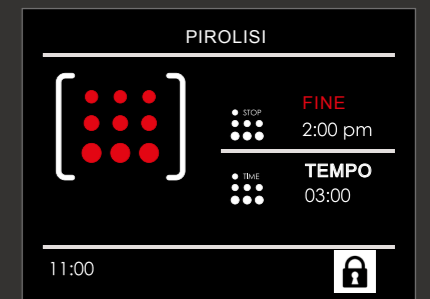
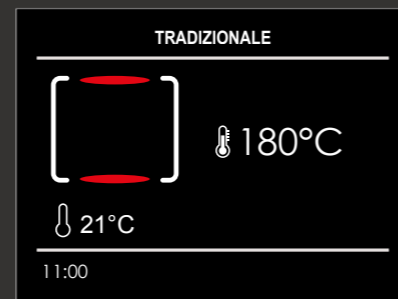
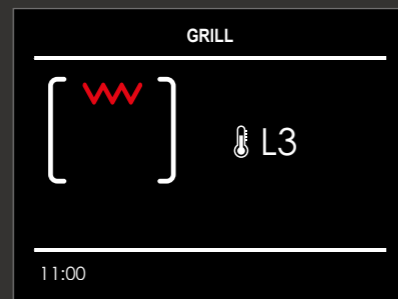

#### MULTILEVEL COOKING

Heat is distributed evenly and consistently inside the oven. You can cook several dishes simultaneously on several levels without contamination, thanks to the assisted ventilation system.

#### GRILLING

The grill function is the best way to brown a steak or roast while keeping it soft and tender.

#### TRADITIONAL CUISINE

This method is perfect for blending flavours naturally while heat is evenly distributed across the oven.

#### PIZZA PIZZERIA 350°C

What a feeling when you bake your dough in a wood-burning oven! Piro Pizza oven is built with top-quality materials and fitted with state-of-the-art technology. It reaches a temperature of 350 °C to cook pizza in just three minutes

#### CUSTOMISABLE RECIPES

The control board uses predefined cooking programs with pre-selected settings to make your life easier when cooking your dishes. However, you can modify cooking times and methods to unleash your creativity and meet everyone's needs.

#### SELF-CLEANING FUNCTION

You can select the self-cleaning function from the display. In this case, the oven's cavity reaches a high temperature to burn off residues of grease or food while the safety system blocks the door. Once the cycle is complete, you can remove the ashes using a damp cloth without detergent.



**XXL 90 Multifunction Oven**

FCLO 9615 TEM 2F BK



- Deep Black finish
- 16 functions
- AirFry (oven-frying) function
- Creative Extended controls
- Meat probe
- Fast Pre-Heat BOOSTER
- Soft Closing
- Telescopic rails
- CLEAN assisted cleaning cycle
- 3-pane glass cool-touch door
- Energy Class A+

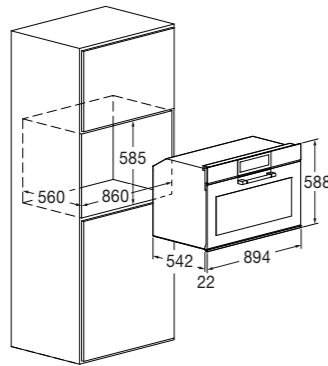

**Features**

The 90 cm multifunction oven is equipped with a practical Touch Control interface that allows you to easily select from numerous preset programs or customize new recipes according to your needs. The large 100-litre cavity enables simultaneous cooking of multiple dishes, while the dual-fan system ensures even heat distribution for uniform cooking results. Thanks to the Meat Probe, you can precisely monitor cooking by measuring the internal temperature of the food. The standard accessory set includes two telescopic guide sets, a temperature probe, an enamelled tray, a flat rack, a rotisserie kit, and an enamelled AirFry tray.

Accessories on request page 305  
 Technical data page 332



DEEP BLACK GLASS  
 FCLO 9615 TEM 2F BK  
 EAN 8019801023288



**XL 75 Multifunction Pyro Oven**

FCLPO 7515 P TEM BK



- Deep Black finish
- 18 functions
- AirFry (oven-frying) function
- Creative Extended controls
- Meat probe
- Fast Pre-Heat BOOSTER
- Soft Closing
- Telescopic rails
- Pyrolytic self-cleaning oven
- 4-pane glass cool-touch door
- Energy Class A+

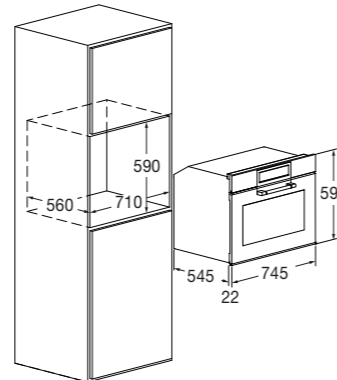

**Features**

Piro Pizza oven cooks pizza at 350 °C in three minutes (Pizza Pizzeria Function). The control panel has different functions, including preset cooking functions and the possibility to modify the recipes. With the Meat Probe, you can monitor the cooking progress by measuring the food core temperature. The oven's cavity is cleaned automatically, thanks to the pyrolytic self-cleaning function. This product comes with the following accessories: two sets of telescopic rails, a Meat Probe, an enamelled tray, a flat rack, an enamelled AirFry tray, and a pizza kit (round grill rack, shovel, and firestone).

Accessories on request page 305  
 Technical data page 333



DEEP BLACK GLASS  
 FCLPO 7515 P TEM BK  
 EAN 8019801037223



**XL 75 Multifunction Oven**

FCLO 7515 TEM BK



- Deep Black finish
- 16 functions
- AirFry (oven-frying) function
- Creative Extended controls
- Meat probe
- Pre-Heat BOOSTER
- Soft Closing
- Telescopic rails
- CLEAN assisted cleaning cycle
- 3-pane glass cool-touch door
- Energy Class A+

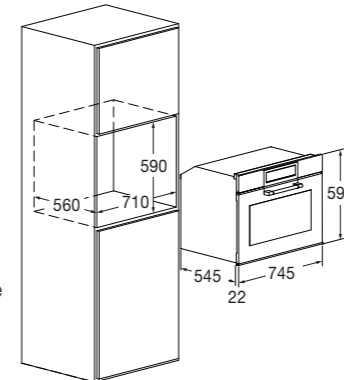

**Features**

Through the elegant and intuitive Touch Control, it is easy to select the preset programs and create and save personalized recipes, ensuring maximum flexibility and precision in every preparation. In the practical 75 cm size, this multifunction oven allows you to cook multiple dishes at the same time. Thanks to the Meat Probe, achieving perfect results is even simpler: you can check the cooking by measuring the internal temperature of the food. The standard accessories include two sets of telescopic guides, a temperature probe, an enamelled tray, a flat grill, a rotisserie kit, and an enamelled tray for AirFry.

Accessories on request page 305  
 Technical data page 332



DEEP BLACK GLASS  
 FCLO 7515 TEM BK  
 EAN 8019801023264



**Steam oven 75x45**

FCLSO 7510 TEM BK



- Deep Black finish
- 11 functions
- AirFry (oven-frying) function
- Creative Extended controls
- Meat probe
- Steam cooking
- Combined cooking
- Steam recovery cycle
- CLEAN assisted cleaning cycle
- 3-pane glass cool-touch door
- Energy Class A++

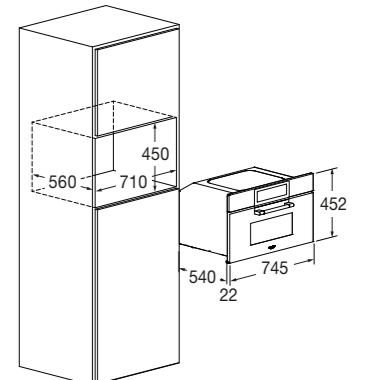

**Features**

The control panel has different functions, including preset cooking functions and the possibility to modify the recipes. With the Meat Probe, you can obtain perfect results because it allows you to monitor the cooking progress by measuring the food core temperature. This product comes with the following accessories: a meat probe, a perforated tray with lid, a stainless steel support for perforated tray, a stainless steel tray, a flat grill rack and a water tank.

Accessories on request page 305  
 Technical data page 334



DEEP BLACK GLASS  
 FCLSO 7510 TEM BK  
 EAN 8019801031979



**Microwave oven 75x45**

FCLMO 7510 TEM BK



- Deep Black finish
- 10 Combined Functions
- AirFry (oven-frying) function
- Creative Extended controls
- Automatic Cooking
- Microwave with 6 power levels
- Microwave & ventilation
- Microwave & grill
- Defrosting
- 3-pane glass cool-touch door

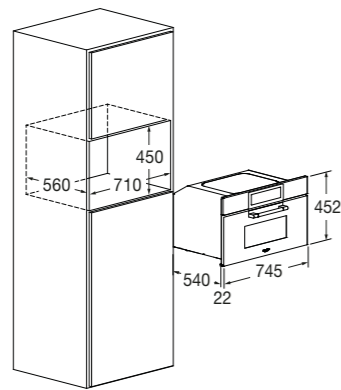

**Features**

The control panel has different functions, including preset cooking functions and the possibility to modify the recipes. Fulgor Milano combi oven is the solution to heat and cook food quickly, combining the advantages of a microwave oven with a traditional ventilated one. A complete and performing household appliance in a small space. With the microwave & ventilation function, you can cook golden broan dishes on the outside and well-cooked on the inside. This product comes with the following accessories: a glass turntable plate, a stainless steel tray, a flat grill rack and a round grill rack.

Accessories on request page 305  
 Technical data page 334



DEEP BLACK GLASS  
 FCLMO 7510 TEM BK  
 EAN 8019801031986



**ATMOS Cluster Steam Oven 60**

FCLSO 6023 TEM BK



- Deep Black finish
- Classic Pizza mode + AirFry
- Meat probe
- TFT touch control display
- 1300 ml water tank
- 11 classic cooking functions
- 6 steam cooking functions
- 7 special cooking functions
- 100% steam in 5 minutes
- Soft Closing
- Energy Class A++

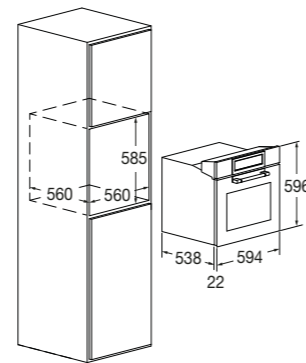

**Features**

Atmos steam oven has 24 cooking functions. Its control panel opens automatically to help you fill the water tank without opening the oven. Numerous are recipes available, even for prolonged cooking (up to 3 hours of continuous steam). Water level sensor and reset notice. Cavity and circuit cleaning and descaling functions. This product comes with the following accessories: fully removable telescopic rails, a Meat Probe, a stainless steel steam kit (perforated tray and surface with support), an AirFry tray, an enamelled tray, and a flat grill rack.

Accessories on request page 305  
 Technical data page 335



DEEP BLACK GLASS  
 FCLSO 6023 TEM BK  
 EAN 8019801031993



**Multifunction Piro Pizza 60**

FCLPO 6215 P TEM BK



- Deep Black finish
- 18 functions
- Pizza Pizzeria 350 °C function
- AirFry (oven-frying) function
- Pyrolytic self-cleaning oven
- Creative Extended controls
- Meat probe
- Fast Pre-Heat BOOSTER
- Soft Closing + Telescopic rails
- 4-pane glass cool-touch door
- Energy Class A+

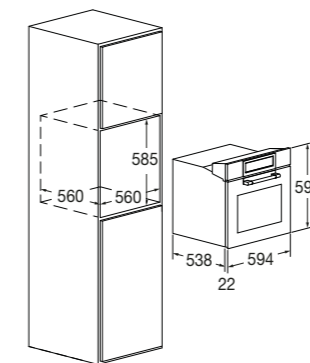

**Features**

Piro Pizza oven cooks pizza at 350 °C in three minutes (Pizza Pizzeria Function). The control panel has different functions, including preset cooking functions and the possibility to modify the recipes. With the Meat Probe, you can monitor the cooking progress by measuring the food core temperature. The oven's cavity is cleaned automatically, thanks to the pyrolytic self-cleaning function. This product comes with the following accessories: two sets of telescopic rails, a Meat Probe, an enamelled tray, a flat rack, an enamelled AirFry tray, and a pizza kit (round grill rack, shovel, and firestone).

Accessories on request page 305  
 Technical data page 336



DEEP BLACK GLASS  
 FCLPO 6215 P TEM BK  
 EAN 8019801023219



**Multifunction Oven 60**

FCLO 6215 TEM BK



- Deep Black finish
- 16 functions
- AirFry (oven-frying) function
- Creative Extended controls
- Meat probe
- Fast Pre-Heat BOOSTER
- Soft Closing
- Telescopic rails
- CLEAN assisted cleaning cycle
- 3-pane glass cool-touch door
- Energy Class A++

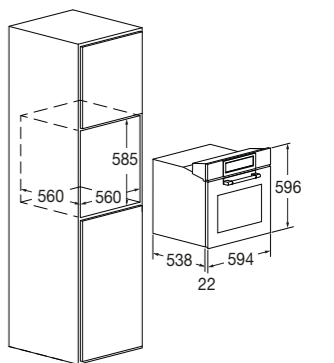

**Features**

The control panel has different functions, including preset cooking functions and the possibility to modify the recipes. With the Meat Probe, you can obtain perfect results because it allows you to monitor the cooking progress by measuring the food core temperature. This product comes with the following accessories: two sets of telescopic rails, a Meat Probe, an enamelled tray, a flat rack, a rotisseries kit and an enamelled AirFry tray.

Accessories on request page 305  
 Technical data page 336



DEEP BLACK GLASS  
 FCLO 6215 TEM BK  
 EAN 8019801023202



**Combi Steam Oven 45**

FCLCSO 4510 TEM BK



- Deep Black finish
- 11 functions
- AirFry (oven-frying) function
- Creative Extended controls
- Meat probe
- Steam cooking
- Combined cooking
- Steam recovery cycle
- CLEAN assisted cleaning cycle
- 3-pane glass cool-touch door
- Energy Class A++

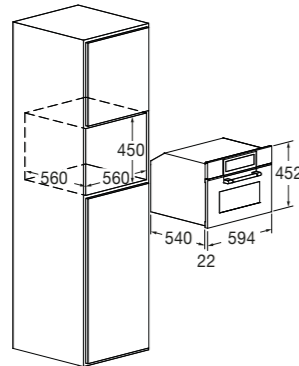

**Features**

Steam ovens cook food gently, healthily, and efficiently while preserving its organoleptic properties. The control panel has different functions, including preset steam cooking functions and the possibility to modify the recipes. With the Meat Probe, you can obtain perfect results because it allows you to monitor the cooking progress by measuring the food core temperature. This product comes with the following accessories: a meat probe, a perforated tray with lid, a stainless steel support for perforated tray, a stainless steel tray, a flat grill rack and a water tank.

Accessories on request page 305  
 Technical data page 337



DEEP BLACK GLASS  
 FCLCSO 4510 TEM BK  
 EAN 8019801023233



**Combi Microwave Oven 45**

FCLCMO 4510 TEM BK



- Deep Black finish
- 10 Combined functions
- AirFry (oven-frying) function
- Creative Extended controls
- Automatic Cooking
- Microwave with 6 power levels
- Cooking with assisted ventilation
- Combined cooking (microwave & grill)
- Defrosting
- 3-pane glass cool-touch door

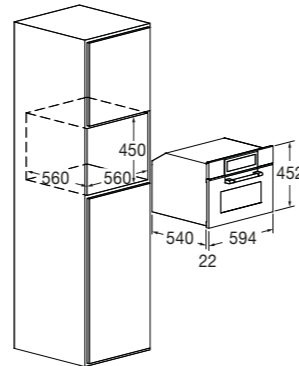

**Features**

The control panel has different functions, including preset cooking functions and the possibility to modify the recipes. Fulgor Milano combi oven is the solution to heat and cook food quickly, combining the advantages of a microwave oven with a traditional ventilated one. A complete and performing household appliance in a small space. With the microwave & ventilation function, you can cook golden brown dishes on the outside and well-cooked on the inside. This product comes with the following accessories: a glass turntable plate, a stainless steel tray, a flat grill rack and a round grill rack.

Accessories on request page 305  
 Technical data page 337



DEEP BLACK GLASS  
 FCLCMO 4510 TEM BK  
 EAN 8019801023226



**Microwave and grill oven 45**

FCLGMO 4508 TEM BK

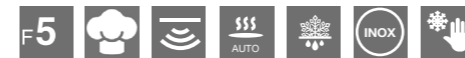

- Deep Black finish
- 5 functions
- Creative Extended controls
- Automatic Cooking
- Microwave with 6 power levels
- Microwave & grill
- Defrosting
- 3-pane glass cool-touch door

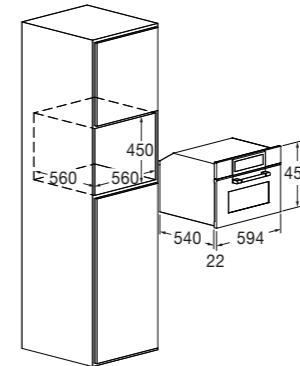

**Features**

FULGOR MILANO microwave oven is perfect for cooking and heating food and beverages. Thanks to the microwave & grill function, your dishes will be perfectly brown and crusty. The control panel has different functions, including preset cooking functions and the possibility to modify the recipes. This product comes with the following accessories: a glass turntable plate, a stainless steel tray, a flat grill rack and a round grill rack.

Accessories on request page 305  
 Technical data page 337



DEEP BLACK GLASS  
 FCLGMO 4508 TEM BK  
 EAN 8019801023240



**Wine Cellar 45**

FCLWC 4500 TC FO BK



- Deep Black finish
- Digital touch display
- Drop-down door
- Adjustable temp. between 5-20 °C
- Capacity: 22 Ø 76 mm bottles
- Telescopic rails
- Soft Closing

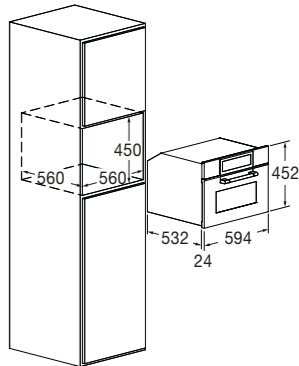

**Features**

FULGOR MILANO's wine cellars are ideal for storing wine. You can set the storage temperature based on the type of wine, with a thermal condition that ranges between 5 °C and 20 °C. Temperature is adjusted using the user-friendly Touch Control system. Moreover, the cellar is equipped with antivibration and anticondensation systems and a UV-insulating glass pane. Internal LED lighting. The cellar's door is fitted with a SOFT CLOSING system that slows the closing movement. This appliance comes with the following accessories: 3 beech wood sliding champagne shelves (4 bottles).

Technical data page 364



DEEP BLACK GLASS  
 FCLWC 4500 TC FO BK  
 EAN 8019801032006

**FULGOR**  
MILANO

**COFFEE IS  
THE BALSAM OF  
THE HEART AND SPIRIT**

(Giuseppe Verdi)

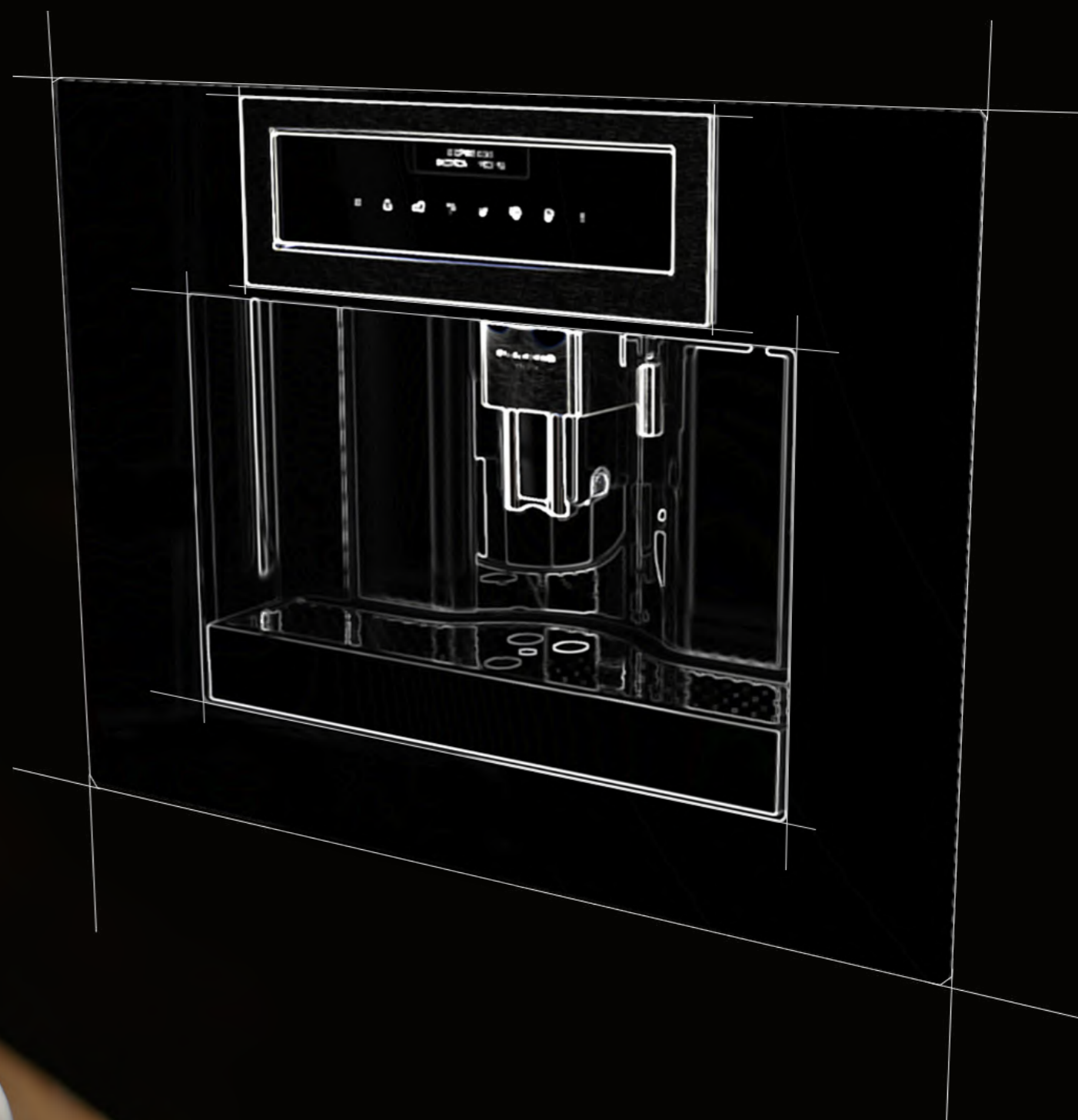



**Coffee machine 45**

FCLCM 4500 TF BK



**Blast chillers 45**

FCLBC 4500 TF BK



- Black finish
- 30 functions
- TFT touch control display
- Automatic programs
- Coffee bean container (200 g)
- Integrated and adjustable grinding
- Milk container
- Water container (1.8 l)
- Removable hot water dispenser
- Liquid collection container
- Five types of cup

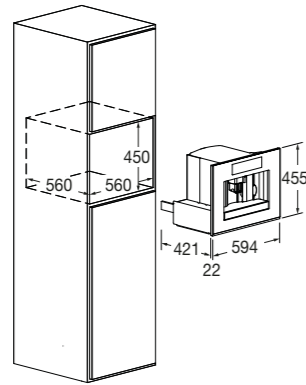

- Deep Black finish
- 11 functions
- TFT touch control display
- Blast chilling temperature + 3°C
- Deep freezing -18°C
- Quick cooling
- Storage at 0°C
- Raw fish sanitation
- Temperature drop to 30 °C
- Defrosting
- Slow cooking + Leavening

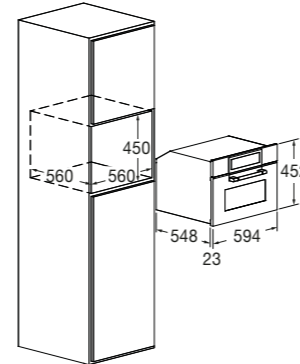

**Features**

This product's design features a user-friendly touch control and digital display. Possibility to choose the type of coffee (e.g. long, short, light or strong) and make teas and herbal teas thanks to the automatic cappuccino maker and the hot water dispenser. The water hardness can also be adjusted. This system can be put on standby to save electricity. Moreover, it is fitted with a safety system, i.e. a warning light to indicate the absence of water or coffee and when it is time to run the cleaning cycle and replace the anti-scale filter. A telescopic opening gives access to the service compartment.

**Features**

The blast chiller has a 40 l capacity. This appliance comes with the following accessories: a meat probe, a heat-resistant glass tray, and a rack. The best results are obtained with the vacuum sealing drawer enhancing the blast chiller functions. This appliance can be combined with the 45 and 60 cm ranges and Fulgor Milano's wide range of drawers.

Technical data page 365

Technical data page 338

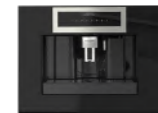

BLACK GLASS  
FCLCM 4500 TF BK  
EAN 8019801024971



DEEP BLACK GLASS  
FCLBC 4500 TF BK  
EAN 8019801019915



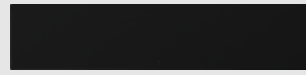

**Warming drawer 15**

FCLWD 150 BK

- Deep Black Glass finish
- 15 cm high front panel
- Adjustable thermostat

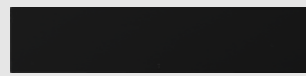

**Storage drawer 15**

FCLD 150 BK

- Deep Black Glass finish
- 15 cm high front panel
- Anti-slip rubber mat

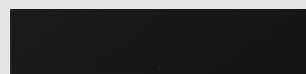

**Vacuum sealing drawer 15**

FCLVSD 150 TC BK

- Deep Black Glass finish
- 15 cm high front panel
- Vacuum chamber container



**Gas hob 90**

FCLH 905 G T WK BK

- Black Glass Ceramic finish
- Halo Vision knobs
- Brass burners



**Gas hob 75**

FCLH 755 G T WK BK

- Black Glass Ceramic finish
- Halo Vision knobs
- Brass burners



**Hybrid hob 90**

FCHH 905 ID TS G DWK BK

- Black Glass Ceramic finish
- Touch Slider controls
- 4 cooking zones (2 vertical bridge zones)

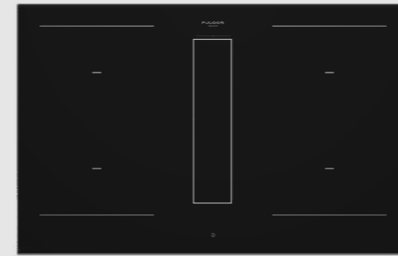

**Aria+ Induction Hob 80**

FHH 800 ID TC BK

- Black Glass Ceramic finish
- Multifunction Touch Control
- 4 cooking zones (2 vertical bridge zones)

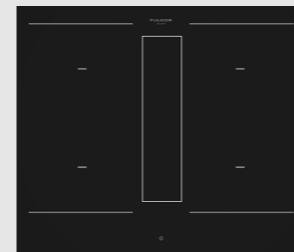

**Aria+ Induction Hob 60**

FHH 600 ID TC BK

- Black Glass Ceramic finish
- Multifunction Touch Control
- 4 cooking zones (2 vertical bridge zones)



**Lift Hood 90**

FDDH 900 TRC BK

- Black Glass finish
- Touch controls and remote control
- 4 suction levels



**Wall-mounted hood 90**

FCLHD 900 TC BK

- Black Glass finish
- Touch controls
- 4 suction levels



**Island hood 90**

FTIHD 960 TC BK X

- Black Glass finish
- Touch controls
- 4 suction levels



**FULGOR**  
MILANO

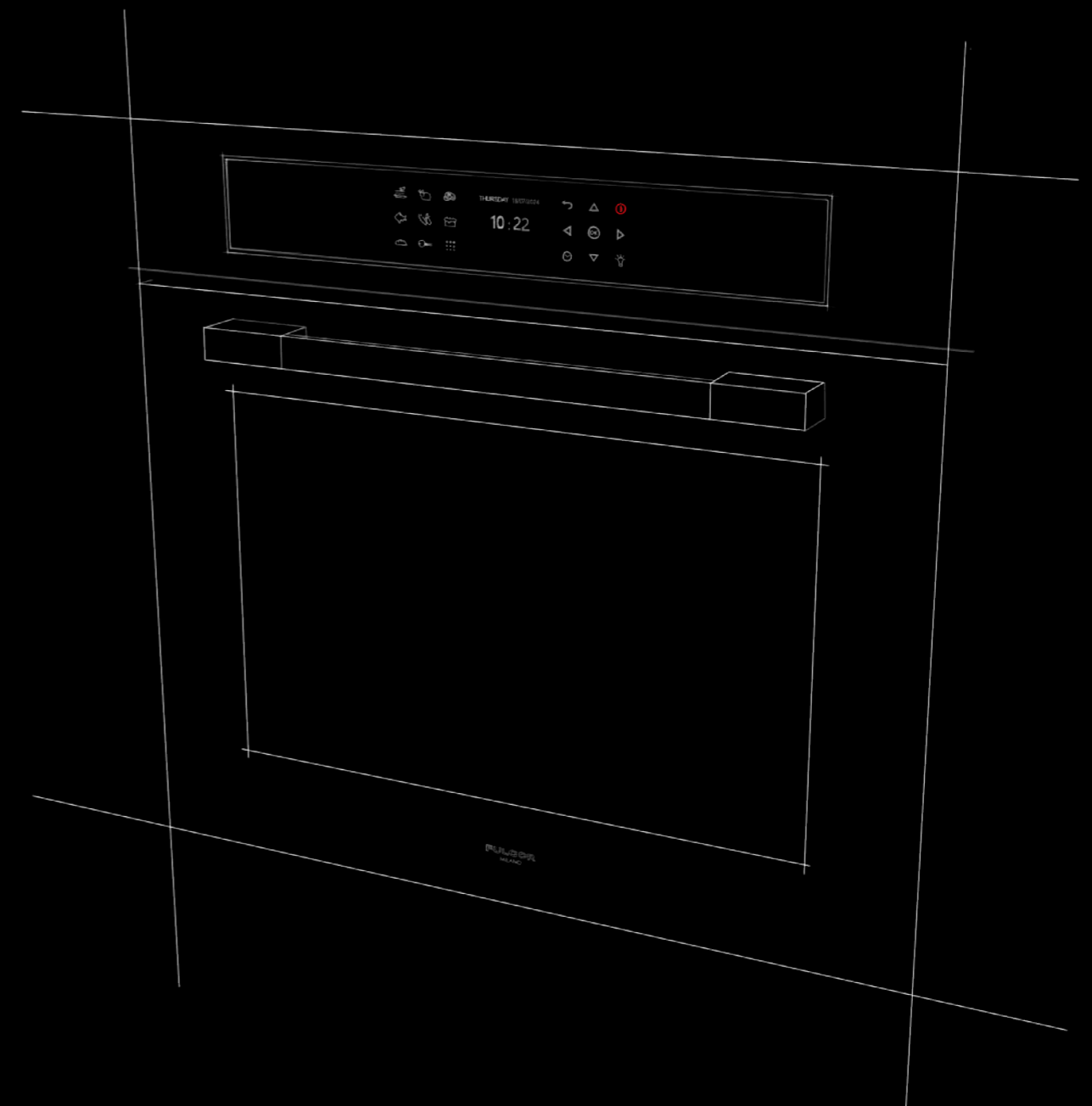

URBANTECH TOUCH

**THE SCENT OF A FRESHLY  
BAKED DESSERT IS THE  
SIMPLEST FORM OF HAPPINESS.**

NEW

**FULGOR**  
MILANO

# URBANTECH TOUCH COLLECTION

We present the Urbantech Touch line: a perfect balance between style and technology. Its exclusive Matte Black Metal finish adds a touch of elegance to any space, while the modern, minimalist design pairs beautifully with an innovative and functional touch control. For those who prefer a classic touch, it is also available in the refined Inox version.

FULGOR  
MILANO

URBANTECH TOUCH

# MULTIFUNCTION OVENS

FULGOR  
MILANO



## CREACTIVE EXTENDED

The Creative EXTENDED operating system offers the possibility to customize preset recipes, adapting them to your needs by adjusting the weight and cooking times. This technology optimizes performance, reduces energy consumption, and expands the available cooking functions. The automatic control system ensures a higher level of safety by detecting and preventing potential malfunctions.

## RECIPES

The control panel offers predefined cooking programs with preset settings to simplify dish preparation. However, to meet individual needs and stimulate creativity, it is possible to customize cooking times, modes, and even create new recipes.

## PIZZA PIZZERIA 350°C

With the Piro Pizza oven, baking your dough like in a wood-fired oven becomes a truly satisfying experience. Thanks to advanced technologies and high-quality materials, it is possible to reach 350°C and bake pizzas in just three minutes.

## AIRFRY

The AirFry mode, available through the control interface of all ovens in the Plano line, allows you to cook crispy foods using very little oil, thanks to an optimally distributed airflow. The AirFry tray, specifically designed for this function, is included as standard or can be purchased separately.

## MEAT PROBE

The Meat Probe sensor measures the internal temperature of foods, monitoring the cooking progress in real time. Thanks to this accessory, it is possible to achieve precise cooking, optimizing the flavor and quality of the dish. During preparation, the screen displays the active function, along with the cavity temperature and the internal temperature of the food.

## TELESCOPIC RAILS

All ovens in the Urbantech Touch line, available in 60, 75, and 90 cm versions, are equipped with telescopic rails. These allow for easy placement of the grill or enamel tray, enabling convenient removal of dishes and simple, safe monitoring of the cooking progress.



**30" Pyro Multifunction**

FUTPO 315 P TEM 2F MBK



- Matte Black Metal finish
- 18 functions
- Pizza Pizzeria 350 °C function
- AirFry (oven-frying) function
- Pyrolytic self-cleaning oven
- Creative Extended controls
- Meat probe
- Fast Pre-Heat BOOSTER
- Interior dual convection
- 4-pane glass cool-touch door
- Energy Class A

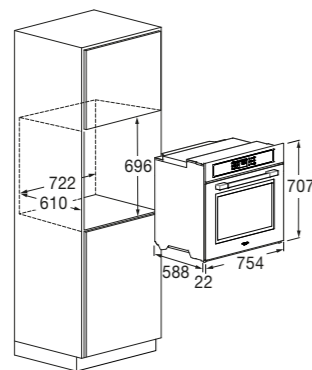

**Features**

With an Extra Large capacity of 125 litres, this oven is perfect for baking large dishes or managing multiple preparations at the same time. The Touch Control system offers a wide range of advanced features, including the "Pizza Pizzeria 350 Function" mode ideal for achieving perfectly baked pizzas in just 3 minutes and the AirFry function. The oven also includes 18 preset cooking programs and the option to customize recipes according to your needs. The standard accessory set includes two full-extension telescopic guides, a temperature probe, a large enamelled tray, a flat rack, an enamelled AirFry tray, and a pizza set (round rack, pizza peel, and refractory stone).

Accessories on request page 305  
 Technical data page 339



MATTE BLACK METAL  
 FUTPO 315 P TEM 2F MBK  
 EAN 8019801034611

STAINLESS STEEL  
 FUTPO 315 P TEM 2F IX  
 EAN 8019801034628



**30" Combi Steam oven**

FUTSO 310 TEM MBK



- Matte Black Metal finish
- 11 combined functions
- AirFry (oven-frying) function
- Creative Extended controls
- Meat probe
- Steam recovery cycle
- Combined cooking
- CLEAN assisted cleaning cycle
- 3-pane glass cool-touch door

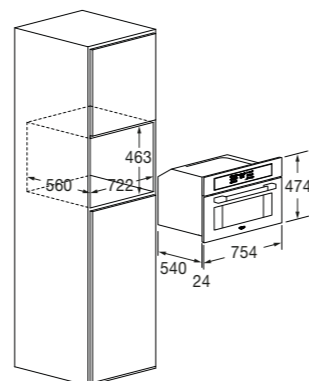

**Features**

The 30" combined steam oven offers a 34-litres internal capacity and 12 versatile cooking functions, including combined cooking, AirFry mode, Steam Boost, and steam reheating. The intuitive Touch Control interface allows you to choose from preset cooking programs or to create and save customised recipes, providing maximum flexibility and precision in the kitchen. The standard accessory set includes a food temperature probe, a perforated tray with lid, a stainless-steel support for the perforated tray, a stainless-steel tray, a flat rack, and a water tank.

Accessories on request page 305  
 Technical data page 340



MATTE BLACK METAL  
 FUTSO 310 TEM MBK  
 EAN 8019801034635

STAINLESS STEEL  
 FUTSO 310 TEM IX  
 EAN 8019801034642



**30" Combi Microwave Oven**

FUTMO 310 TEM MBK



- Matte Black Metal finish
- 10 Combined functions
- AirFry (oven-frying) function
- Creative Extended controls
- Automatic Cooking
- Microwave with 6 power levels
- Cooking with assisted ventilation
- Combined cooking
- Defrosting
- 3-pane glass cool-touch door

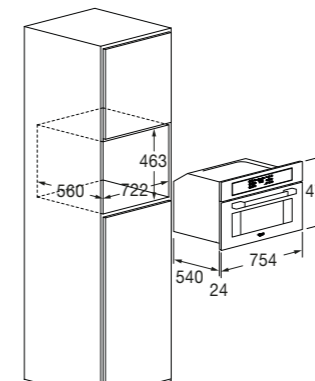

**Features**

The microwave in this collection combines innovation and versatility, integrating traditional cooking modes with microwave technology. The intuitive Touch Control allows you to easily select preset programs and to create and save customized recipes, ensuring maximum flexibility and precision in every preparation. The standard accessory set includes a turnable glass, a round rack, a flat rack, and an AirFry cooking tray.

Accessories on request page 305  
 Technical data page 340



MATTE BLACK METAL  
 FUTMO 310 TEM MBK  
 EAN 8019801034659

STAINLESS STEEL  
 FUTMO 310 TEM IX  
 EAN 8019801034666



**90 Multifunction Oven**

FUTO 9615 TEM 2F MBK



- Matte Black Metal finish
- 16 functions
- AirFry (oven-frying) function
- Creative Extended controls
- Meat probe
- Fast Pre-Heat BOOSTER
- Soft Closing
- Telescopic rails
- CLEAN assisted cleaning cycle
- 3-pane glass cool-touch door
- Energy Class A+

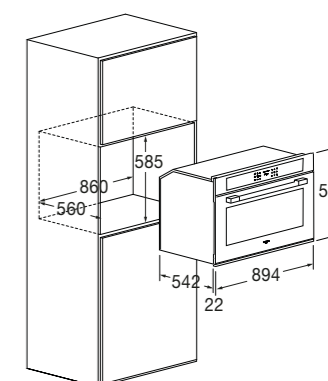

**Features**

The 90 cm multifunction oven is equipped with a practical Touch Control interface that allows you to easily select from numerous preset programs or customize new recipes according to your needs. The large 100-litre cavity enables simultaneous cooking of multiple dishes, while the dual-fan system ensures even heat distribution for uniform cooking results. Thanks to the Meat Probe, you can precisely monitor cooking by measuring the internal temperature of the food. The standard accessory set includes two telescopic guide sets, a temperature probe, an enamelled tray, a flat rack, a rotisserie kit, and an enamelled AirFry tray.

Accessories on request page 305  
 Technical data page 341



MATTE BLACK METAL  
 FUTO 9615 TEM 2F MBK  
 EAN 8019801034444

STAINLESS STEEL  
 FUTO 9615 TEM 2F IX  
 EAN 8019801034437



**XL 75 Multifunction Pyro Oven** ⚡  
FUTPO 7515 P TEM MBK



- Matte Black Metal finish
- 18 functions
- AirFry (oven-frying) function
- Creative Extended controls
- Meat probe
- Fast Pre-Heat BOOSTER
- Soft Closing
- Telescopic rails
- Pyrolytic self-cleaning oven
- 4-pane glass cool-touch door
- Energy Class A+

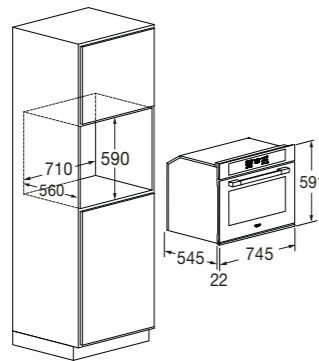

**Features**

Piro Pizza oven cooks pizza at 350 °C in three minutes (Pizza Pizzeria Function). The control panel has different functions, including preset cooking functions and the possibility to modify the recipes. With the Meat Probe, you can monitor the cooking progress by measuring the food core temperature. The oven's cavity is cleaned automatically, thanks to the pyrolytic self-cleaning function. This product comes with the following accessories: two sets of telescopic rails, a Meat Probe, an enamelled tray, a flat rack, an enamelled AirFry tray, and a pizza kit (round grill rack, shovel, and firestone).

Accessories on request page 305  
Technical data page 341



MATTE BLACK METAL  
FUTPO 7515 P TEM MBK  
EAN 8019801034468



STAINLESS STEEL  
FUTPO 7515 P TEM IX  
EAN 8019801034451



**XL 75 Multifunction Oven** ⚡  
FUTO 7515 TEM MBK



- Matte Black Metal Finish
- 16 functions
- AirFry
- Creative Extended
- Meat Probe
- Fast Pre-Heat BOOSTER
- Soft Closing
- Telescopic rails
- CLEAN assisted cleaning cycle
- 3-pane glass cool-touch door
- Energy Class A+

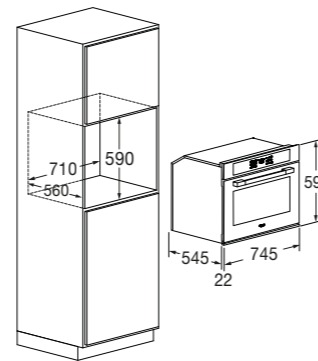

**Features**

Through the elegant and intuitive Touch Control, it is easy to select the preset programs and create and save personalized recipes, ensuring maximum flexibility and precision in every preparation. In the practical 75 cm size, this multifunction oven allows you to cook multiple dishes at the same time. Thanks to the Meat Probe, achieving perfect results is even simpler: you can check the cooking by measuring the internal temperature of the food. The standard accessories include two sets of telescopic guides, a temperature probe, an enamelled tray, a flat grill, a rotisserie kit, and an enamelled tray for AirFry.

Accessories on request page 305  
Technical data page 342



MATTE BLACK METAL  
FUTO 7515 TEM MBK  
EAN 8019801035076



STAINLESS STEEL  
FUTO 7515 TEM IX  
EAN 8019801035069



**Steam oven 75x45** ⚡  
FUTCSO 7510 TEM MBK



- Matte Black Metal finish
- 11 functions
- AirFry (oven-frying) function
- Creative Extended controls
- Meat probe
- Steam cooking
- Combined cooking
- Steam recovery cycle
- CLEAN assisted cleaning cycle
- 3-pane glass cool-touch door
- Energy Class A++

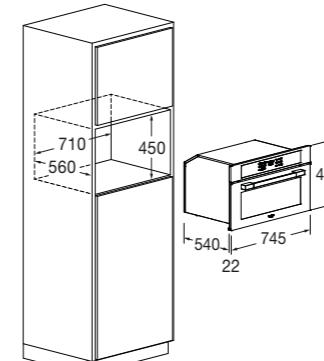

**Features**

The control panel has different functions, including preset cooking functions and the possibility to modify the recipes. With the Meat Probe, you can obtain perfect results because it allows you to monitor the cooking progress by measuring the food core temperature. This product comes with the following accessories: a meat probe, a perforated tray with lid, a stainless steel support for perforated tray, a stainless steel tray, a flat grill rack and a water tank.

Accessories on request page 305  
Technical data page 343



MATTE BLACK METAL  
FUTCSO 7510 TEM MBK  
EAN 8019801034482



STAINLESS STEEL  
FUTCSO 7510 TEM IX  
EAN 8019801034475



**Microwave Oven 75x45** ⚡  
FUTCMO 7510 TEM MBK



- Matte Black Metal finish
- 10 functions
- AirFry (oven-frying) function
- Creative Extended controls
- Automatic Cooking
- Combined cooking
- Microwave with 6 power levels
- Microwave & ventilation
- Microwave & grill
- Defrosting
- 3-pane glass cool-touch door

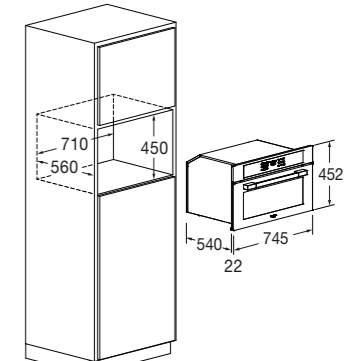

**Features**

The control panel has different functions, including preset cooking functions and the possibility to modify the recipes. Fulgor Milano combi oven is the solution to heat and cook food quickly, combining the advantages of a microwave oven with a traditional ventilated one. A complete and performing household appliance in a small space. With the microwave & ventilation function, you can cook golden brown dishes on the outside and well-cooked on the inside. This product comes with the following accessories: a glass turntable plate, a stainless steel tray, a flat grill rack and a round grill rack.

Accessories on request page 305  
Technical data page 343



MATTE BLACK METAL  
FUTCMO 7510 TEM MBK  
EAN 8019801034505



STAINLESS STEEL  
FUTCMO 7510 TEM IX  
EAN 8019801034499



**ATMOS Steam Oven 60**

FUTSO 6023 TEM MBK



- Matte Black Metal finish
- Classic Pizza Mode
- AirFry (oven-frying) function
- TFT touch control display
- 1500 ml water tank
- 11 classic cooking functions
- 6 steam cooking functions
- 7 special cooking functions
- Meat Probe
- Soft Closing
- Energy Class A++

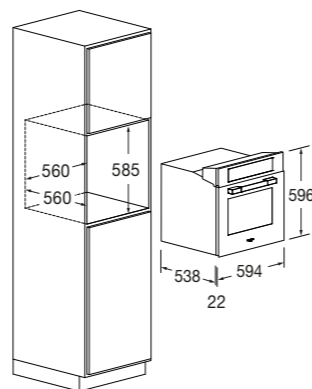

**Features**

Atmos steam oven has 24 cooking functions. Its control panel opens automatically to help you fill the water tank without opening the oven. Numerous are recipes available, even for prolonged cooking (up to 3 hours of continuous steam). Water level sensor and reset notice. Cavity and circuit cleaning and descaling functions. This product comes with the following accessories: fully removable telescopic rails, a Meat Probe, a stainless steel steam kit (perforated tray and surface with support), an AirFry tray, an enamelled tray, and a flat grill rack.

Accessories on request  
Technical data

page 305  
page 344



MATTE BLACK METAL  
FUTSO 6023 TEM MBK  
EAN 8019801034529

STAINLESS STEEL  
FUTSO 6023 TEM IX  
EAN 8019801034512



**Multifunction Pyro Pizza 60**

FUTPO 6215 P TEM MBK



- Matte Black Metal finish
- 18 functions
- Pizza Pizzeria 350°C function
- AirFry (oven-frying) function
- Pyrolytic self-cleaning oven
- Creative Extended controls
- Meat probe
- Fast Pre-Heat BOOSTER
- Soft Closures + Telescopic rails
- 4-pane glass cool-touch door
- Energy Class A+

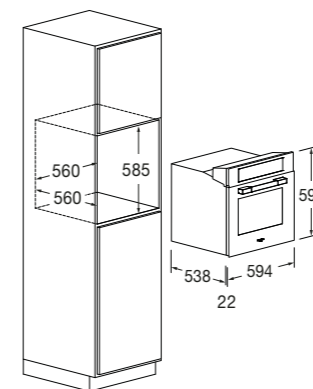

**Features**

Piro Pizza oven cooks pizza at 350 °C in three minutes (Pizza Pizzeria Function). The control panel has different functions, including preset cooking functions and the possibility to modify the recipes. With the Meat Probe, you can monitor the cooking progress by measuring the food core temperature. The oven's cavity is cleaned automatically, thanks to the pyrolytic self-cleaning function. This product comes with the following accessories: two sets of telescopic rails, a Meat Probe, an enamelled tray, a flat rack, an enamelled AirFry tray, and a pizza kit (round grill rack, shovel, and firestone).

Accessories on request  
Technical data

page 305  
page 345



MATTE BLACK METAL  
FUTPO 6215 P TEM MBK  
EAN 8019801034673

STAINLESS STEEL  
FUTPO 6215 P TEM IX  
EAN 8019801034680



**Multifunction Oven 60**

FUTO 6215 TEM MBK



- Matte Black Metal finish
- 16 functions
- AirFry (oven-frying) function
- Creative Extended controls
- Meat probe
- Fast Pre-Heat BOOSTER
- CLEAN assisted cleaning cycle
- Soft Closing
- Telescopic rails
- 3-pane glass cool-touch door
- Energy Class A++

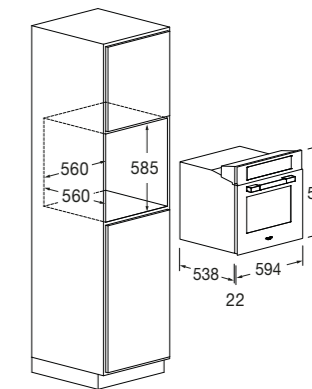

**Features**

The control panel has different functions, including preset cooking functions and the possibility to modify the recipes. With the Meat Probe, you can obtain perfect results because it allows you to monitor the cooking progress by measuring the food core temperature. This product comes with the following accessories: two sets of telescopic rails, a Meat Probe, an enamelled tray, a flat rack, a rotisseries kit and an enamelled AirFry tray.

Accessories on request  
Technical data

page 305  
page 345



MATTE BLACK METAL  
FUTO 6215 TEM MBK  
EAN 8019801034697

STAINLESS STEEL  
FUTO 6215 TEM IX  
EAN 8019801034703

FULGOR  
MILANO

# URBANTECH TOUCH STEAM OVEN



Discover all the benefits of the steam cooking: a modern technique that renews the way we cook, making it healthier, more natural, and more efficient. This method preserves the essential nutrients of foods and enhances their authentic flavors, allowing you to prepare tasty and light dishes. Ventilation ensures the distribution of the heat, guaranteeing perfectly uniform cooking. Each dish thus becomes a genuine, well-balanced, and flavorful experience.

## URBANTECH TOUCH

OVEN



### Combi Steam Oven 45

FUTSO 4510 TEM MBK



- Matte Black Metal finish
- 11 functions
- AirFry (oven-frying) function
- Creative Extended controls
- Meat probe
- Steam cooking
- Combined cooking
- Steam recovery cycle
- CLEAN assisted cleaning cycle
- 3-pane glass cool-touch door
- Energy Class A++

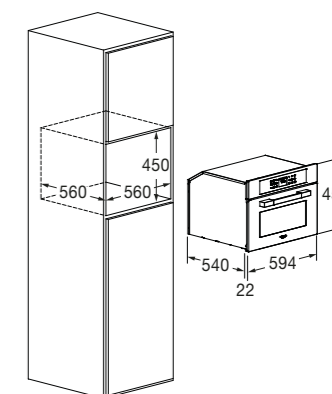

### Features

Steam ovens cook food gently, healthily, and efficiently while preserving its organoleptic properties. The control panel has different functions, including preset steam cooking functions and the possibility to modify the recipes. With the Meat Probe, you can obtain perfect results because it allows you to monitor the cooking progress by measuring the food core temperature. This product comes with the following accessories: a meat probe, a perforated tray with lid, a stainless steel support for perforated tray, a stainless steel tray, a flat grill rack and a water tank.

Accessories on request  
Technical data

page 305  
page 346



MATTE BLACK METAL  
FUTSO 4510 TEM MBK  
EAN 8019801034710



STAINLESS STEEL  
FUTSO 4510 TEM IX  
EAN 8019801034727



Microwave combi oven 60x45

FUTMO 4510 TEM MBK



- Matte Black Metal finish
- 10 functions
- AirFry (oven-frying) function
- Creative Extended controls
- Automatic Cooking
- Microwave with 6 power levels
- Microwave & ventilation
- Microwave & grill
- Defrosting
- 3-pane glass cool-touch door

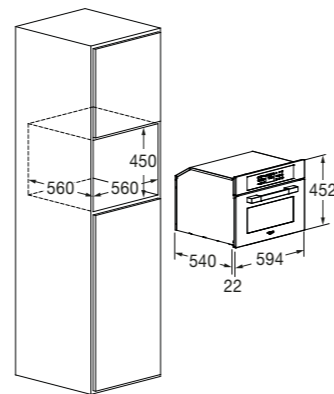

Features

The control panel has different functions, including preset cooking functions and the possibility to modify the recipes. Fulgor Milano combi oven is the solution to heat and cook food quickly, combining the advantages of a microwave oven with a traditional ventilated one. A complete and performing household appliance in a small space. With the microwave & ventilation function, you can cook golden broan dishes on the outside and well-cooked on the inside. This product comes with the following accessories: a glass turntable plate, a stainless steel tray, a flat grill rack and a round grill rack.

Accessories on request  
 Technical data

page 305  
 page 347



MATTE BLACK METAL  
 FUTMO 4510 TEM MBK  
 EAN 8019801034734



STAINLESS STEEL  
 FUTMO 4510 TEM IX  
 EAN 8019801034741

FULGOR  
 MILANO

URBANTECH TOUCH  
 MICROWAVE OVEN



In addition to the traditional quick cooking, the FULGOR MILANO microwave also offers grill and convection modes, which can be used individually or combined thanks to the “combi” function. In a compact space, it connects the advantages of microwave cooking with those of a traditional oven, ensuring optimal results in a short time.

The “Recipes” function allows you to prepare meat, fish, desserts, and many other dishes using preset programs developed by professional chefs. Simply selecting the desired recipe, the microwave will automatically set the ideal cooking mode, temperature, and time for a perfect result.

FULGOR  
MILANO

# URBANTECH TOUCH COFFEE MACHINE



## THE ART OF COFFEE IN YOUR HOME

The Fulgor Milano coffee machine controls every stage of the preparation with precision: from bean storage to grinding, from coffee extraction to the automatic collection of used coffee grounds, all the way to programmed automatic cleaning. Every type of coffee—whether an espresso, a long coffee, or a cappuccino—can be prepared with ease. The Urbantech Touch line, with its modern, minimalist design, combined with an innovative touch control system, it integrates perfectly with your kitchen style.

## EXCELLENCE IN PREPARATION

Thanks to this coffee machine, it is possible to select different intensity levels: extra strong, strong, medium, light, and very light. In addition, with the “cappuccinatore” accessory, you can prepare a perfect cappuccino. The advanced integrated bean-grinding technology ensures coffee that is always fresh and with an impeccable flavor. With the hot water and steam dispenser, you can prepare a wide range of beverages such as tea, herbal teas, and infusions. Among the available functions, the automatic rinsing mode ensures maximum hygiene and convenience.

## URBANTECH TOUCH

OVEN



### Built-In Coffee machine 45

FUTCM 4500 TF MBK



- Matte Black Metal finish
- 30 functions
- TFT touch control display
- Automatic programs
- Coffee bean container (200 g)
- Integrated and adjustable grinding
- Milk container (0,75 l)
- Water container (1.8 l)
- Removable hot water dispenser
- Liquid collection container
- Five types of cup

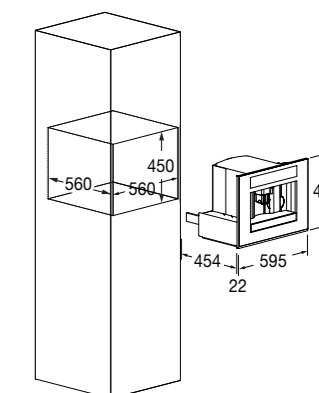

## Features

This product's design features a user-friendly touch control and digital display. Possibility to choose the type of coffee (e.g. long, short, light or strong) and make teas and herbal teas thanks to the automatic cappuccino maker and the hot water dispenser. The water hardness can also be adjusted. This system can be put on standby to save electricity. Moreover, it is fitted with a safety system, i.e. a warning light to indicate the absence of water or coffee and when it is time to run the cleaning cycle and replace the anti-scale filter. A telescopic opening gives access to the service compartment.

Technical data

page 365



MATTE BLACK METAL  
FUTCM 4500 TF MBK  
EAN 8019801034758



STAINLESS STEEL  
FUTCM 4500 TF IX  
EAN 8019801034765



**Wine Cellar 45**

FUTWC 4500 TC FO MBK



- Matte Black Metal finish
- Digital touch display
- Drop-down door
- Adjustable temperature between 5 and 20°C
- Capacity: 22 Ø 76 mm bottles
- Telescopic rails
- Soft Closing

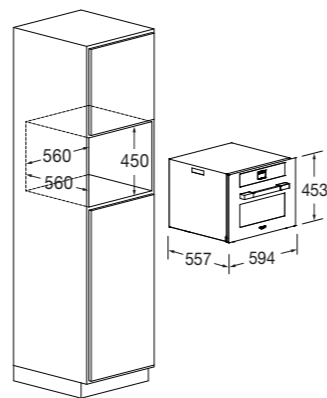

**Features**

FULGOR MILANO's wine cellars are ideal for storing wine. You can set the storage temperature based on the type of wine, with a thermal condition that ranges between 5 °C and 20 °C. Temperature is adjusted using the user-friendly Touch Control system. Moreover, the cellar is equipped with antivibration and anticondensation systems and a UV-insulating glass pane. Internal LED lighting. The cellar's door is fitted with a SOFT CLOSING system that slows the closing movement. This appliance comes with the following accessories: 3 beech wood sliding champagne shelves (4 bottles).

Technical data

page 364



MATTE BLACK METAL  
FUTWC 4500 TC FO MBK  
EAN 8019801034543



STAINLESS STEEL  
FUTWC 4500 TC FO IX  
EAN 8019801034536

FULGOR  
MILANO

URBANTECH TOUCH  
WINE CELLAR



EXCELLENCE IN EVERY BOTTLE

Fulgor Milano wine cellars provide the ideal environment to preserve your wine bottles at their best. The storage temperature is easily adjustable and can range from 5°C to 20°C, depending on the specific needs of each type of wine. Equipped with three natural wooden shelves, the cellar offers space for 22 bottles. The upper shelf is designed to accommodate bottles with a larger diameter, while the two lower shelves are perfect for smaller bottles.

An advanced anti-vibration system ensures that the sediments settle properly at the bottom of the bottle. In addition, the anti-condensation system maintains a constant humidity level between 60% and 80%, creating the ideal conditions for the wine to mature slowly and perfectly.

ELEGANCE AND PERFORMANCE

Adjusting the storage conditions of the wine cellar has never been easier, thanks to the electronic touch control system. Equipped with telescopic rails, the cellar allows the shelves to glide effortlessly, ensuring convenient and immediate access to the bottles. The door, made of insulated glass, protects the wine from harmful UV rays. Inside, the LED lighting provides uniform illumination that prevents overheating while enhancing the beauty of your wine collection.

**FULGOR**  
MILANO

THE SIGHT AND SMELL OF FRESHLY BAKED BREAD  
HAS A ROMANTIC APPEAL THAT TRANSCENDS  
ANY OTHER CULINARY ACHIEVEMENT

(Elisabeth Luard)



URBANTECH OVENS

**FULGOR**  
MILANO

# URBANTECH MATTE BLACK LINE

The URBANTECH range combines a modern minimalist design with ever-green classic lines. The philosophy behind URBANTECH can be summarised in one sentence: Less is more.

As Adolf Loos once said: "Don't fear being judged as non-modern. Changes in the traditional way of building are only permitted if they are an improvement. Otherwise, stay with what is traditional." This philosophy has inspired the design of this product range, where the classic knob control is completed with a functional digital display. The various timing functions are easy to set and clearly intelligible.

The Matte Black Metal finish of this range includes Fulgor Milano's iconic Badge and unique and ergonomic URBANTECH handle. Even multifunction ovens are fitted with a Soft-Closing system, which, combined with the various cooking modes, will allow you to unleash your culinary creativity.

**FULGOR**  
MILANO

FULGOR  
MILANO

# URBANTECH MATTE BLACK

FULGOR  
MILANO



## URBANTECH DESIGN

With its matte black painted steel finish, the URBANTECH range reveals a unique, pleasant, essential and memorable design. URBANTECH develops a range of built-in, steam and microwave ovens, where you can choose among a variety of sizes and uses.

## URBANTECH TECHNIQUE

URBANTECH ovens combine the precision of electronics with the ergonomic design of the knob controls. Direct, immediate, and easily intelligible function setting. The UltraBlack pyrolytic enamel of the cavity and accessories makes the oven easy to clean. URBANTECH pyro ovens are fitted with two interior lights to improve visibility.

# OVENS MULTIFUNCTION MATTE BLACK

75|90

FULGOR  
MILANO



URBANTECH multifunction ovens are also available in 75 and 90 cm. Their maxi cavity (89 and 105 l) allows you to cook several dishes simultaneously.

Thanks to the state-of-the-art auxiliary ventilation system, hot air circulates evenly, thus ensuring excellent results, regardless of how the dish is positioned inside the oven.



**XXL 90 Multifunction Oven**

FUO 9609 MT MBK



- Matte Black Metal finish
- Metal knobs
- 10 functions
- Digit Timer (on-off) | Knobs
- Ventilation cooking
- Soft Closing
- Telescopic rails
- 3-pane glass cool-touch door
- Energy Class A

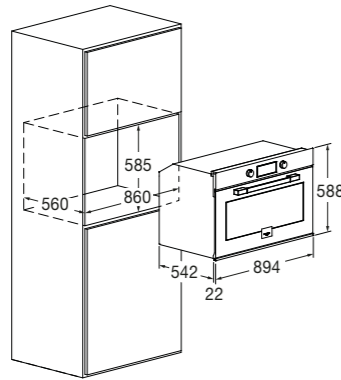

**Features**

This product stands out for its classic user-friendly knob control completed with a functional digital display. The various timing functions are easy to set and clearly intelligible. The URBANTECH oven reveals a unique, pleasant, essential design that doesn't go unnoticed. It features a 105 l ultra black enamelled cooking chamber. Moreover, it's fitted with an efficient safety system, including tangential cooling ventilation. This product comes with the following accessories: set of fully removable telescopic rails, enamelled tray, flat rack, and rotisseries kit.

Accessories on request page 305  
 Technical data page 348



MATTE BLACK METAL  
 FUO 9609 MT MBK  
 EAN 8019801031252



**Ventilated Gas Oven 90**

FUTO 9605 FG EM 2F MBK



- Matte Black Metal finish
- Metal knobs
- 4 functions
- Digit Timer | Knobs
- Gas burner
- Electric grill
- Assisted cooking
- Ventilation cooking
- Soft Closing
- 3-pane glass cool-touch door
- Energy Class A

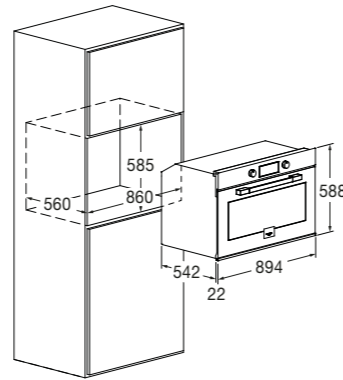

**Features**

This product stands out for its classic user-friendly knob control completed with a functional digital display. The various timing functions are easy to set and clearly intelligible. The oven features a 96 l ultra black enamelled cooking chamber. Moreover, it's fitted with an efficient safety system, including a gas detection and stop system. This product comes with the following accessories: set of fully removable telescopic rails, enamelled tray, flat rack, and rotisseries kit.

Accessories on request page 305  
 Technical data page 349



MATTE BLACK METAL  
 FUTO 9605 FG EM 2F MBK  
 EAN 8019801034253



**Multifunction Oven 75**

FUO 7509 MT MBK



- Matte Black Metal finish
- Metal knobs
- 10 functions
- Digit Timer (on-off) | Knobs
- Ventilation cooking
- Soft Closing
- Telescopic rails
- 3-pane glass cool-touch door
- Energy Class A

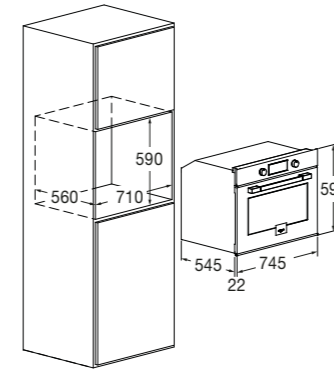

**Features**

This product stands out for its classic user-friendly knob control completed with a functional digital display. The various timing functions are easy to set and clearly intelligible. This oven features an 89 l ultra black enamelled cavity. Moreover, it's fitted with an efficient safety system, including tangential cooling ventilation. This product comes with the following accessories: set of fully removable telescopic rails, a tray, a flat rack, and a rotisseries kit.

Accessories on request page 305  
 Technical data page 350



MATTE BLACK METAL  
 FUO 7509 MT MBK  
 EAN 8019801031245



**Steam oven 75x45**

FUSO 7505 MT MBK



- Matte Black Metal finish
- Metal knobs
- 2 functions
- Digit Timer (on-off) | Knobs
- Steam cooking
- Grill
- Automatic descaling system
- Safe door
- Energy Class A++

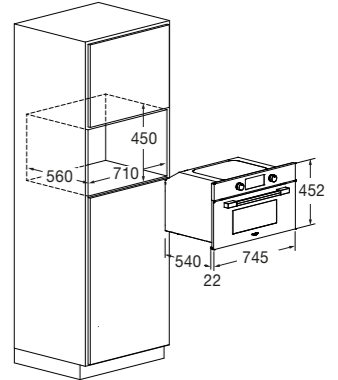

**Features**

Steam ovens cook food gently, healthily, and efficiently while preserving its organoleptic properties. The oven features a 34 l stainless steel cooking chamber. Moreover, it's fitted with an efficient safety system, including a door contact switch and tangential cooling ventilation. The appliance comes with the following accessories: a perforated tray with lid, a stainless steel support for perforated tray, a stainless steel tray, a flat grill rack and a water tank.

Accessories on request page 305  
 Technical data page 350



MATTE BLACK METAL  
 FUSO 7505 MT MBK  
 EAN 8019801032037



**Microwave oven 75x45**

FUGMO 7505 MT MBK



- Matte Black Metal finish
- Metal knobs
- 3 functions
- Digit Timer (on-off) | Knobs
- Microwave with 6 power levels
- Microwave & grill
- Defrosting
- 3-pane glass cool-touch door

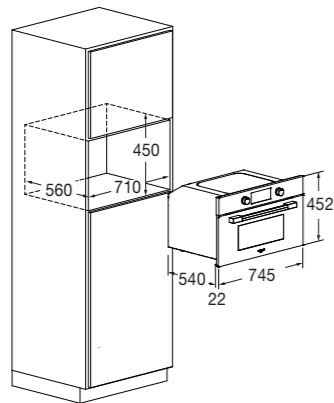

**Features**

This product stands out for its classic user-friendly knob control completed with a functional digital display. The various timing functions are easy to set and clearly intelligible. The oven features a 34 l stainless steel cooking chamber. Moreover, it's fitted with an efficient safety system, including a door with a safety lock and tangential cooling ventilation. The appliance comes with a glass turntable plate, a flat grill rack and a round grill rack.

Accessories on request page 305  
 Technical data page 351



MATTE BLACK METAL  
 FUGMO 7505 MT MBK  
 EAN 8019801032044



**Piro Multifunction Oven 60**

FUO 6011 P MT MBK



- Matte Black Metal finish
- Metal knobs
- 9 functions
- Pyrolytic self-cleaning oven
- Digit Control | Knobs
- Ventilation cooking
- Soft Closing
- Telescopic rails
- 4-pane glass cool-touch door
- Energy Class A+

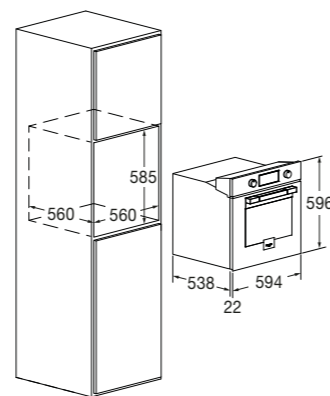

**Features**

This product stands out for its user-friendly knob control completed with a functional digital display. The various timing functions are easy to set and clearly intelligible. The oven features a 65 l ultra black enamelled cooking chamber. Moreover, it's fitted with an efficient safety system, including a door with an automatic lock during the self-cleaning cycle, a control panel with safety switch and tangential cooling ventilation. This product comes with the following accessories: set of fully removable telescopic rails, a tray, and two flat grill racks.

Accessories on request page 305  
 Technical data page 351



MATTE BLACK METAL  
 FUO 6011 P MT MBK  
 EAN 8019801027910



**Multifunction Oven 60**

FUO 6009 MT MBK



- Matte Black Metal finish
- Metal knobs
- 9 functions
- Digit Timer (on-off) | Knobs
- Ventilation cooking
- Soft Closing
- Telescopic rails
- 3-pane glass cool-touch door
- Energy Class A

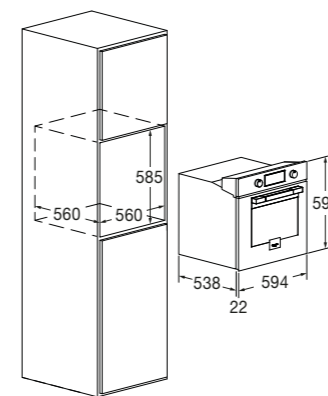

**Features**

This product stands out for its classic user-friendly knob control completed with a functional digital display. The various timing functions are easy to set and clearly intelligible. The oven features a 65 l ultra black enamelled cooking chamber. Moreover, it's fitted with an efficient safety system, including tangential cooling ventilation. This product comes with the following accessories: set of fully removable telescopic rails, a tray, and a flat rack.

Accessories on request page 305  
 Technical data page 352



MATTE BLACK METAL  
 FUO 6009 MT MBK  
 EAN 8019801027903



**Ventilated Gas Oven 60**

FUTO 6005 FG EM MBK



- Matte Black finish
- Metal knobs
- 3 functions
- Digit Timer | Knobs
- Gas burner
- Ventilation cooking
- Timer
- 3-pane glass cool-touch door
- Energy Class A+

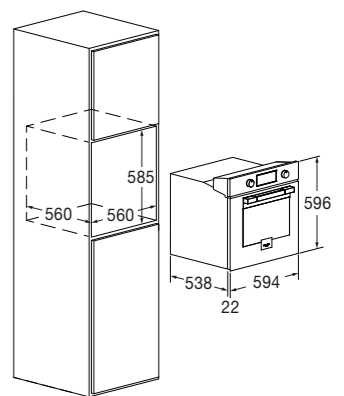

**Features**

This product stands out for its classic user-friendly knob control completed with a functional digital display. The various timing functions are easy to set and clearly intelligible. The URBANTECH oven reveals a unique, pleasant, essential design that doesn't go unnoticed. The oven features a 65 l ultra black enamelled cooking chamber. This product comes with the following accessories: enamelled tray, flat rack, and rotisserie kit.

Accessories on request page 305  
 Technical data page 352



MATTE BLACK METAL  
 FUTO 6005 FG EM MBK  
 EAN 8019801034246



**Grill steam oven 45**

FUSO 4505 MT MBK



- Matte Black Metal finish
- Metal knobs
- 2 functions
- Digit Timer (on-off) | Knobs
- Steam cooking
- Grill
- Automatic descaling system
- 3-pane glass cool-touch door
- Energy Class A++

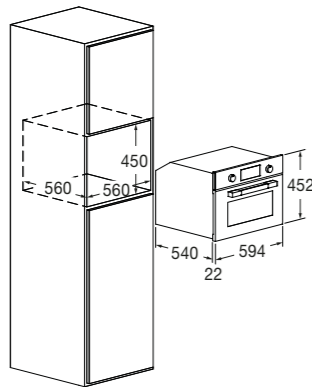

**Features**

Steam ovens cook food gently, healthily, and efficiently while preserving its organoleptic properties. The oven features a 34 l stainless steel cooking chamber. Moreover, it's fitted with an efficient safety system, including a door contact switch and tangential cooling ventilation. The appliance comes with the following accessories: a perforated tray with lid, a stainless steel support for perforated tray, a stainless steel tray, a flat grill rack and a water tank.

Accessories on request page 305  
 Technical data page 353



MATTE BLACK METAL  
 FUSO 4505 MT MBK  
 EAN 8019801027880



**Microwave and grill oven 45**

FUGMO 4505 MT MBK



- Matte Black Metal finish
- Metal knobs
- 3 functions
- Digit Timer (on-off) | Knobs
- Microwave with 6 power levels
- Microwave & grill
- Defrosting
- 3-pane glass cool-touch door

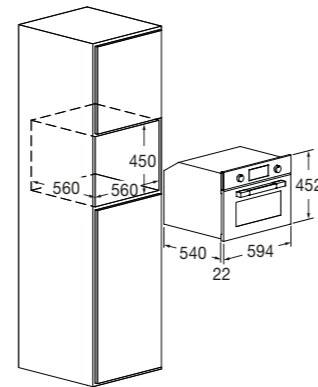

**Features**

This product stands out for its classic user-friendly knob control completed with a functional digital display. The various timing functions are easy to set and clearly intelligible. The oven features a 34 l stainless steel cooking chamber. Moreover, it's fitted with an efficient safety system, including a door with a safety lock and tangential cooling ventilation. The appliance comes with the following accessories: a glass turntable plate, a flat grill rack and a round grill rack.

Accessories on request page 305  
 Technical data page 353



MATTE BLACK METAL  
 FUGMO 4505 MT MBK  
 EAN 8019801027897



**Coffee machine 45**

FUCM 4500 TF MBK



- Matte Black Metal finish
- 30 functions
- TFT touch control display
- Automatic programs
- Coffee bean container (200 g)
- Integrated and adjustable grinding
- Milk container
- Water container (1.8 l)
- Removable hot water dispenser
- Liquid collection container
- Five types of cup

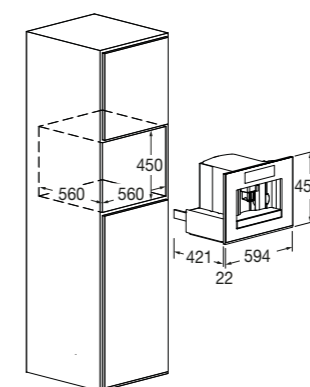

**Features**

This product's design features a user-friendly touch control and digital display. Possibility to choose the type of coffee (e.g. long, short, light or strong) and make teas and herbal teas thanks to the automatic cappuccino maker and the hot water dispenser. The water hardness can also be adjusted. This system can be put on standby to save electricity. Moreover, it is fitted with a safety system, i.e. a warning light to indicate the absence of water or coffee and when it is time to run the cleaning cycle and replace the anti-scale filter. A telescopic opening gives access to the service compartment.

Technical data page 365



MATTE BLACK METAL  
 FUCM 4500 TF MBK  
 EAN 8019801030408



**Wine Cellar 45**

FUWC 4500 TC FO MBK



- Matte Black Metal finish
- Digital touch display
- Drop-down door
- Adjustable temperature between 5 and 20 °C
- Capacity: 22 Ø 76 mm bottles
- Telescopic rails
- Soft Closing

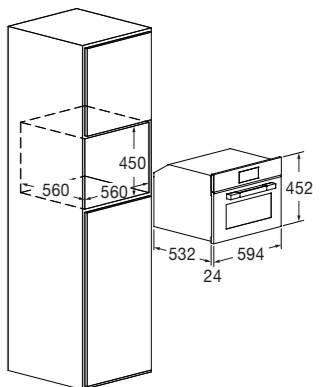

**Features**

FULGOR MILANO's wine cellars are ideal for storing wine. You can set the storage temperature based on the type of wine, with a thermal condition that ranges between 5 °C and 20 °C. Temperature is adjusted using the user-friendly Touch Control system. Moreover, the cellar is equipped with antivibration and anticondensation systems and a UV-insulating glass pane. Internal LED lighting. The cellar's door is fitted with a SOFT CLOSING system that slows the closing movement. This appliance comes with the following accessories: 3 beech wood sliding champagne shelves (4 bottles).

Technical data page 364



MATTE BLACK METAL  
 FUWC 4500 TC FO MBK  
 EAN 8019801032051

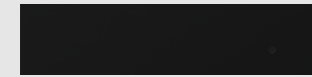

**Warming drawer 15**

FUWD 150 MBK

- Matte Black Metal finish
- 15 cm high front panel
- Adjustable thermostat



**Storage drawer 15**

FUD 150 MBK

- Matte Black Metal finish
- 15 cm high front panel
- Anti-slip rubber mat



**Gas hob 90**

FUH 905 G DWK MBK

- Matte Black Metal finish
- Electronic ignition
- Matte black brass burners



**Gas hob 90**

FUH 9041 G DWK MBK

- Matte Black Metal finish
- Electronic ignition
- Matte black brass burners



**Gas hob 75**

FUH 755 G DWK MBK

- Matte Black Metal finish
- Electronic ignition
- Matte black brass burners



**Gas hob 60**

FUH 604 G DWK MBK

- Matte Black Metal finish
- Electronic ignition
- Matte black brass burners



**Induction hob 90**

FSH 905 ID WT MBK

- Matte Black Glass Ceramic finish
- WAVE Touch Slider controls
- 5 cooking zones



**Induction hob 80**

FSH 804 ID WT MBK

- Matte Black Glass Ceramic finish
- WAVE Touch Slider controls
- 4 cooking zones

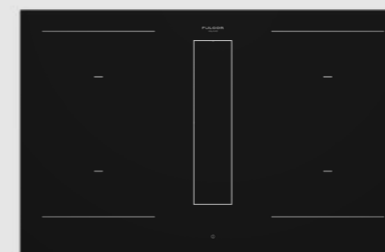

**Aria+ Induction Hob 80**

FHH 800 ID TC BK

- Black Glass Ceramic finish
- Multifunction Touch Control
- 4 cooking zones (2 vertical bridge zones)

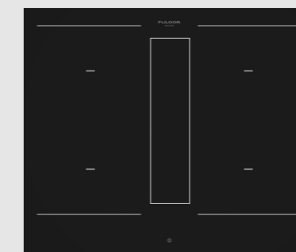

**Aria+ Induction Hob 60**

FHH 600 ID TC BK

- Black Glass Ceramic finish
- Multifunction Touch Control
- 4 cooking zones (2 vertical bridge zones)



**FULGOR**  
MILANO

# URBANTECH STAINLESS STEEL AND BLACK GLASS



## URBANTECH DESIGN

Besides the elegant matte black metal version, URBANTECH is available with stainless steel and black glass finishes. This product stands out for its classic user-friendly knob control completed with a functional digital display. The various timing functions are easy to set and clearly intelligible.

The URBANTECH range reveals a unique, pleasant, essential design that doesn't go unnoticed. A wide range of products (electrical and/or gas), e.g. multifunction ovens, steam ovens, coffee machines, wine cellars, etc., where you can choose among a variety of sizes and uses is available.



**XXL 90 Multifunction Oven**

FUTO 9609 MT IX



- Stainless steel finish
- Metal knobs
- 10 functions
- Digit Timer (on-off) | Knobs
- Ventilation cooking
- Soft Closing
- Telescopic rails
- 3-pane glass cool-touch door
- Energy Class A

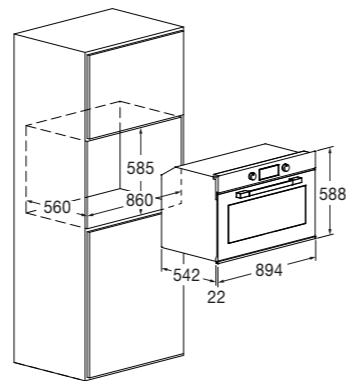

**Features**

This product stands out for its classic user-friendly knob control completed with a functional digital display. The various timing functions are easy to set and clearly intelligible. The URBANTECH oven reveals a unique, pleasant, essential design that doesn't go unnoticed. It features a 105 l ultra black enamelled cooking chamber. Moreover, it's fitted with an efficient safety system, including tangential cooling ventilation. This product comes with the following accessories: set of fully removable telescopic rails, enamelled tray, flat rack, and rotisseries kit.

Accessories on request  
 Technical data

page 305  
 page 348



STAINLESS STEEL  
 FUTO 9609 MT IX  
 EAN 8019801032068



**Ventilated Gas Oven 90**

FUTO 9605 FG EM 2F IX



- Stainless steel finish
- Metal knobs
- 4 functions
- Digit Timer | Knobs
- Gas burner
- Electric grill
- Assisted cooking
- Ventilation cooking
- Soft Closing
- 3-pane glass cool-touch door
- Energy Class A

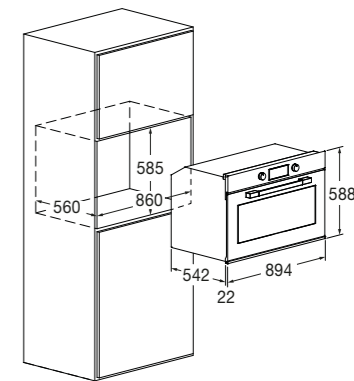

**Features**

This product stands out for its classic user-friendly knob control completed with a functional digital display. The various timing functions are easy to set and clearly intelligible. The oven features a 96 l ultra black enamelled cooking chamber. Moreover, it's fitted with an efficient safety system, including a gas detection and stop system. This product comes with the following accessories: set of fully removable telescopic rails, enamelled tray, flat rack, and rotisseries kit.

Accessories on request  
 Technical data

page 305  
 page 349



STAINLESS STEEL  
 FUTO 9605 FG EM 2F IX  
 EAN 8019801032075



BLACK GLASS  
 FUTO 9605 FG EM 2F GBK  
 EAN 8019801037193



**Multifunction Oven 75**

FUTO 7509 MT IX



- Stainless steel finish
- Metal knobs
- 10 functions
- Digit Timer (on-off) | Knobs
- Ventilation cooking
- Soft Closing
- Telescopic rails
- 3-pane glass cool-touch door
- Energy Class A

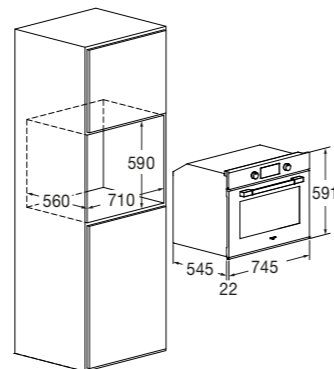

**Features**

This product stands out for its classic user-friendly knob control completed with a functional digital display. The various timing functions are easy to set and clearly intelligible. The URBANTECH oven reveals a unique, pleasant, essential design that doesn't go unnoticed. This model features an 89 l ultra black enamelled cooking chamber. Moreover, it's fitted with an efficient safety system, including tangential cooling ventilation. This product comes with the following accessories: set of fully removable telescopic rails, enamelled tray, flat rack, and rotisserie kit.

Accessories on request  
Technical data

page 305  
page 350



STAINLESS STEEL  
FUTO 7509 MT IX  
EAN 8019801032099

BLACK GLASS  
FUTO 7509 MT GBK  
EAN 8019801032181



**Steam oven 75x45**

FUSO 7505 MT IX



- Stainless steel finish
- Metal knobs
- 2 functions
- Digit Timer (on-off) | Knobs
- Steam cooking
- Grill
- Automatic descaling system
- Safe door
- Energy Class A++

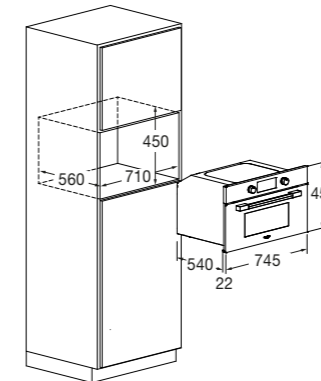

**Features**

Steam ovens cook food gently, healthily, and efficiently while preserving its organoleptic properties. The oven features a 34 l stainless steel cooking chamber. Moreover, it's fitted with an efficient safety system, including a door contact switch and tangential cooling ventilation. The appliance comes with the following accessories: a perforated tray with lid, a stainless steel support for perforated tray, a stainless steel tray, a flat grill rack and a water tank.

Accessories on request  
Technical data

page 305  
page 350



STAINLESS STEEL  
FUSO 7505 MT IX  
EAN 8019801032105

BLACK GLASS  
FUSO 7505 MT GBK  
EAN 8019801032198



**Microwave oven 75x45**

FUGMO 7505 MT IX



- Stainless steel finish
- Metal knobs
- 3 functions
- Digit Timer (on-off) | Knobs
- Microwave with 4 power levels
- Microwave & grill
- Grill
- Defrosting
- 3-pane glass cool-touch door

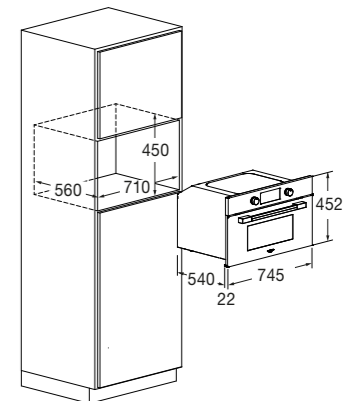

**Features**

This product stands out for its classic user-friendly knob control completed with a functional digital display. The various timing functions are easy to set and clearly intelligible. The oven features a 34 l stainless steel cooking chamber. Moreover, it's fitted with an efficient safety system, including a door with a safety lock, a door contact switch, and tangential cooling ventilation. The appliance comes with the following accessories: a glass turntable plate, a flat grill rack and a round grill rack.

Accessories on request  
Technical data

page 305  
page 351



STAINLESS STEEL  
FUGMO 7505 MT IX  
EAN 8019801032112

BLACK GLASS  
FUGMO 7505 MT GBK  
EAN 8019801032204



**Multifunction Oven Pyro 60**

FUTO 6011 P MT IX



- Stainless steel finish
- Metal knobs
- 9 functions
- Pyrolytic self-cleaning oven
- Digit Control | Knobs
- Ventilation cooking
- Soft Closing
- Telescopic rails
- 4-pane glass cool-touch door
- Energy Class A+

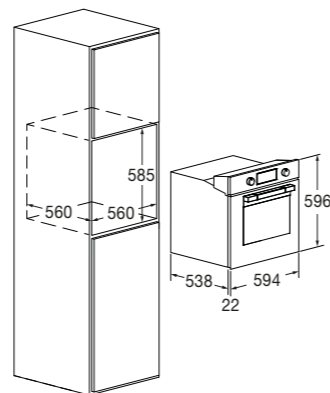

**Features**

This product stands out for its user-friendly knob control completed with a functional digital display. The various timing functions are easy to set and clearly intelligible. The oven features a 65 l ultra black enamelled cooking chamber. Moreover, it's fitted with an efficient safety system, including a door with an automatic lock during the self-cleaning cycle, a control panel with safety switch and tangential cooling ventilation.

This product comes with the following accessories: set of fully removable telescopic rails, a tray, and two flat grill racks.

Accessories on request  
Technical data

page 305  
page 351



STAINLESS STEEL  
FUTO 6011 P MT IX  
EAN 8019801032907



BLACK GLASS  
FUTO 6011 P MT GBK  
EAN 8019801032914



**Multifunction Oven 60**

FUTO 6009 MT IX



- Stainless steel finish
- Metal knobs
- 9 functions
- Digit Timer (on-off) | Knobs
- Ventilation cooking
- Soft Closing
- Telescopic rails
- 3-pane glass cool-touch door
- Energy Class A

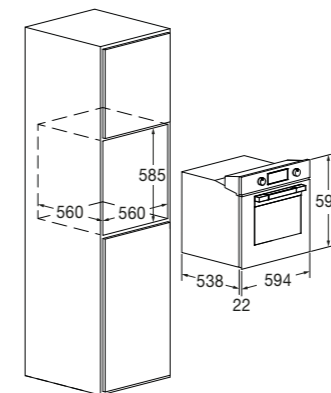

**Features**

This product stands out for its classic user-friendly knob control completed with a functional digital display. The various timing functions are easy to set and clearly intelligible. The URBANTECH oven reveals a unique, pleasant, essential design that doesn't go unnoticed. The oven features a 65 l ultra black enamelled cooking chamber. Moreover, it's fitted with an efficient safety system, including tangential cooling ventilation.

This product comes with the following accessories: set of fully removable telescopic rails, enamelled tray, and flat rack.

Accessories on request  
Technical data

page 305  
page 352



STAINLESS STEEL  
FUTO 6009 MT IX  
EAN 8019801032129



BLACK GLASS  
FUTO 6009 MT GBK  
EAN 8019801032211



**Ventilated Gas Oven 60**

FUTO 6005 FG EM IX



- Stainless steel finish
- Metal knobs
- 3 functions
- Digit Timer | Knobs
- Gas burner
- Ventilation cooking
- Timer
- 3-pane glass cool-touch door
- Energy Class A+

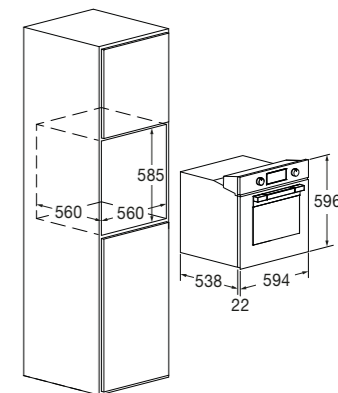

**Features**

This product stands out for its classic user-friendly knob control completed with a functional digital display. The various timing functions are easy to set and clearly intelligible. The URBANTECH oven reveals a unique, pleasant, essential design that doesn't go unnoticed. The oven features a 65 l ultra black enamelled cooking chamber.

This product comes with the following accessories: enamelled tray, flat rack, and rotisseries kit.

Accessories on request  
Technical data

page 305  
page 352



STAINLESS STEEL  
FUTO 6005 FG EM IX  
EAN 8019801032136



BLACK GLASS  
FUTO 6005 FG EM GBK  
EAN 8019801037209



**Grill steam oven 45**  
FUTGSO 4505 MT IX



- Stainless steel finish
- Metal knobs
- 2 functions
- Digit Timer (on-off) | Knobs
- Steam cooking
- Grill
- Automatic descaling system
- Safe door
- Energy Class A++

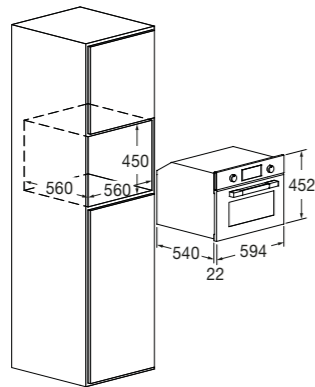

**Features**

Steam ovens cook food gently, healthily, and efficiently while preserving its organoleptic properties. The oven features a 34 l stainless steel cooking chamber. Moreover, it's fitted with an efficient safety system, including a door contact switch and tangential cooling ventilation. The appliance comes with the following accessories: a perforated tray with lid, a stainless steel support for perforated tray, a stainless steel tray, a flat grill rack and a water tank.

Accessories on request page 305  
Technical data page 353



STAINLESS STEEL  
FUTGSO 4505 MT IX  
EAN 8019801032143



BLACK GLASS  
FUTGSO 4505 MT GBK  
EAN 8019801032228



**Microwave and grill oven 45**  
FUTGMO 4505 MT IX



- Stainless steel finish
- Metal knobs
- 3 functions
- Digit Timer (on-off) | Knobs
- Microwave with 6 power levels
- Microwave & grill
- Grill
- Defrosting
- 3-pane glass cool-touch door

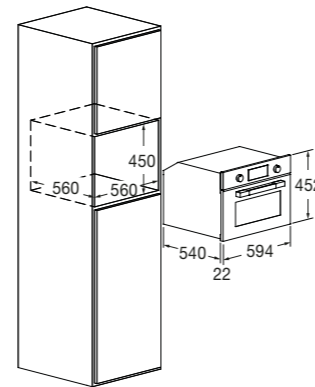

**Features**

This product stands out for its classic user-friendly knob control completed with a functional digital display. The various timing functions are easy to set and clearly intelligible. The oven features a 34 l stainless steel cooking chamber. Moreover, it's fitted with an efficient safety system, including a door with a safety lock and tangential cooling ventilation. The appliance comes with the following accessories: a glass turntable plate, a flat grill rack and a round grill rack.

Accessories on request page 305  
Technical data page 353



STAINLESS STEEL  
FUTGMO 4505 MT IX  
EAN 8019801032150



BLACK GLASS  
FUTGMO 4505 MT GBK  
EAN 8019801032235



**Coffee machine 45**  
FUCM 4500 TF IX



- Stainless steel finish
- 30 functions
- TFT touch control display
- Automatic programs
- Coffee bean container (200 g)
- Integrated and adjustable grinding
- Milk container
- Water container (1.8 l)
- Removable hot water dispenser
- Liquid collection container
- Five types of cup

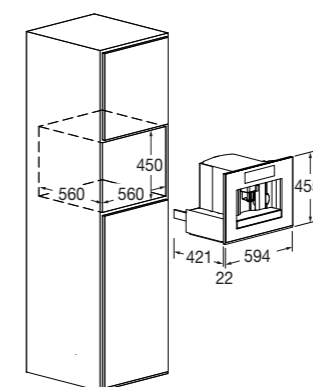

**Features**

This product's design features a user-friendly touch control and digital display. Possibility to choose the type of coffee (e.g. long, short, light or strong) and make teas and herbal teas thanks to the automatic cappuccino maker and the hot water dispenser. The water hardness can also be adjusted. This system can be put on standby to save electricity. Moreover, it is fitted with a safety system, i.e. a warning light to indicate the absence of water or coffee and when it is time to run the cleaning cycle and replace the anti-scale filter. A telescopic opening gives access to the service compartment.

Technical data page 365



STAINLESS STEEL  
FUCM 4500 TF IX  
EAN 8019801032167



**Wine Cellar 45**  
FUWC 4500 TC FO IX



- Stainless steel finish
- Digital touch display
- Drop-down door
- Adjustable temp. between 5-20 °C
- Capacity: 22 Ø 76 mm bottles
- Telescopic rails
- Soft Closing

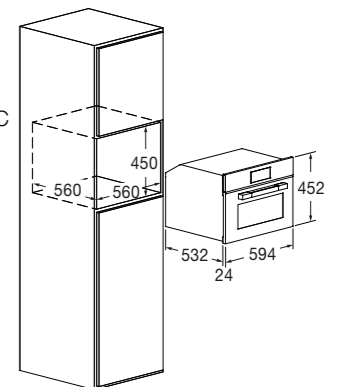

**Features**

FULGOR MILANO's wine cellars are ideal for storing wine. You can set the storage temperature based on the type of wine, with a thermal condition that ranges between 5 °C and 20 °C. Temperature is adjusted using the user-friendly Touch Control system. Moreover, the cellar is equipped with antivibration and anticondensation systems and a UV-insulating glass pane. Internal LED lighting. The cellar's door is fitted with a SOFT CLOSING system that slows the closing movement. This appliance comes with the following accessories: 3 beech wood sliding champagne shelves (4 bottles).

Technical data page 364



STAINLESS STEEL  
FUWC 4500 TC FO IX  
EAN 8019801032174



**Storage drawer 15**

FD 150 X

- Stainless steel structure
- 15 cm high front panel
- Anti-slip rubber mat



**Warming drawer 15**

FWD 150 X

- Stainless steel structure
- 15 cm high front panel
- Adjustable thermostat

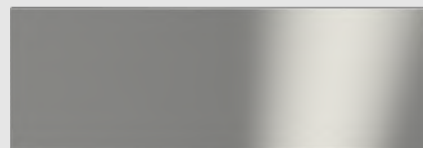

**Warming drawer 27**

FWD 3024 X

- Stainless steel finish
- 27 cm high front panel
- Adjustable thermostat



**Gas hob 90**

FPH 905 G WK X

- Stainless steel structure
- Electric ignition under the knob
- Burners with brass flame spreader



**Gas hob 90**

FPH 9041 G WK X

- Stainless steel structure
- Electric ignition under the knob
- Burners with brass flame spreader



**Gas hob 75**

FPH 755 G WK X

- Stainless steel structure
- Electric ignition under the knob
- Burners with brass flame spreader

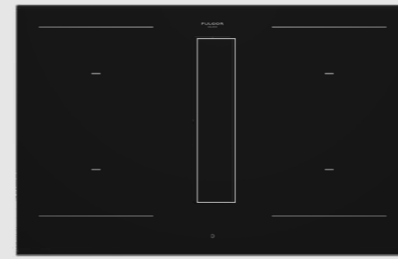

**Aria+ Induction Hob 80**

FHH 800 ID TC BK

- Black Glass Ceramic finish
- Multifunction Touch Control
- 4 cooking zones (2 vertical bridge zones)



**Induction hob 90**

FSH 905 ID WT BK

- Black Glass Ceramic finish
- WAVE Touch Slider controls
- 5 cooking zones



**Induction hob 80**

FSH 804 ID WT BK

- Black Glass Ceramic finish
- WAVE Touch Slider controls
- 4 cooking zones

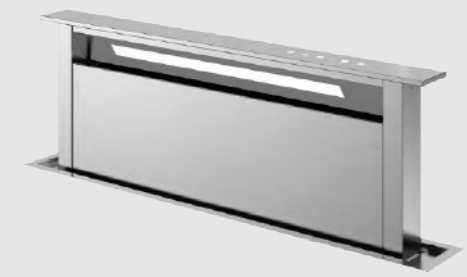

**Lift Hood 90**

FDDH 900 TRC X

- Stainless steel finish
- 4 suction levels
- LED bar lighting



**Wall-mounted hood 90**

FTHD 900 TC X

- Stainless steel finish
- Touch controls
- 4 suction levels



**Integrated hood 85**

FBGHD 850 TC X

- Stainless steel finish
- Touch controls
- 4 suction levels



**FULGOR**  
MILANO

**THE PIZZA FILLS THE SPACE WITH  
COLOURS AND SCENTS. THEN WHEN IT  
ARRIVES ON THE TABLE, THE WORLD  
FALLS IN LOVE**

*(Fabrizio Caramagna)*



**PIZZA PIZZERIA 350°C**

**FULGOR**  
MILANO



# PLANO

Plano ovens hint at classic shapes while standing out for their unique and innovative design. These products feature a metal handle and an electronic touch control system with a dual keyboard, which allows you to launch the required function with a simple touch. Three finishes available: stainless steel, glossy black glass, and glossy white glass.

PLANO IN GRANDE

# MULTIFUNCTION OVENS

**FULGOR**  
MILANO



## CREACTIVE EXTENDED

The CREAACTIVE EXTENDED operating system allows you to adapt preset recipes to your needs, varying the weight and cooking time. This system improves the overall performance, reduces energy consumption, and increases the number of cooking functions. Even safety is improved, thanks to the automatic control system that warns and prevents damage.

## RECIPES

The control board uses predefined cooking programs with pre-selected settings to make your life easier when cooking your dishes. However, creativity comes with the possibility to modify the cooking times and methods to create new recipes.

## PIZZA PIZZERIA 350°C

What a feeling when you bake your dough in a wood-burning oven! Piro Pizza oven is built with top-quality materials and fitted with state-of-the-art technology. It reaches a temperature of 350 °C to cook pizza in just three minutes

## AIRFRY

The AirFry function can be selected from the control interface of every Plano oven. This function distributes air evenly to have crispy food with very little oil. The AirFry tray comes with the oven or can be purchased separately.

## MEAT PROBE

The Meat Probe monitors the food temperature, digitally controlling the cooking process. This accessory helps enhance the food's flavour. While cooking, you can view the selected function, the temperature of the cavity and the food's core from the display.

## TELESCOPIC RAILS

All PLANO 60/75/90 ovens are fitted with telescopic rails. You can place the grill rack and enamelled tray on these rails so you can easily remove them to check the progress of your dishes.

PLANO IN GRANDE

# MULTIFUNCTION OVENS

**FULGOR**  
MILANO



FULGOR MILANO has increased the size of three built-in ovens – PiroPizza multifunction oven, steam oven, and microwave oven – creating the PLANO IN GRANDE range. Each product has specific features to meet different cooking requirements. They always ensure the best performance, whether installed together or separately.

## EXTRA LARGE CAVITY

These three products have a 30-inch width (76.2 cm) to allow you to use different cooking levels efficiently and simultaneously.

## HALOGEN LIGHTING

The three offset lights improve visibility inside the cavity, making it easy to check the cooking progress.

## COOL-TOUCH DOOR

Thanks to the four heat-reflecting glass panes, the external door remains warm to the touch, even during the self-cleaning cycle.



**XXL 30" Piro Multifunction**

**FCPO 315 P TEM 2F X**



- Stainless steel finish
- 18 functions
- Pizza Pizzeria 350 °C function
- AirFry (oven-frying) function
- Pyrolytic self-cleaning oven
- Creative Extended controls
- Meat probe
- Fast Pre-Heat BOOSTER
- Interior dual convection
- 4-pane glass cool-touch door
- Energy Class A

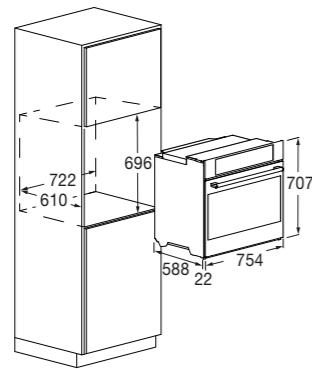

**Features**

With an Extra Large capacity of 125 litres, this oven is perfect for baking large dishes or managing multiple preparations at the same time. The Touch Control system offers a wide range of advanced features, including the "Pizza Pizzeria 350 Function" mode ideal for achieving perfectly baked pizzas in just 3 minutes and the AirFry function. The oven also includes 18 preset cooking programs and the option to customize recipes according to your needs. The standard accessory set includes two full-extension telescopic guides, a temperature probe, a large enamelled tray, a flat rack, an enamelled AirFry tray, and a pizza set (round rack, pizza peel, and refractory stone).

Accessories on request page 305  
 Technical data page 354



STAINLESS STEEL  
 FCPO 315 P TEM 2F X  
 EAN 8019801027279

BLACK GLASS  
 FCPO 315 P TEM 2F BK  
 EAN 8019801033317



**30" Combined Steam oven**

**FCSO 310 TEM X**

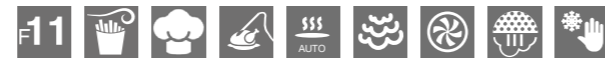

- Stainless steel finish
- 12 combined functions
- AirFry (oven-frying) function
- Creative Extended controls
- Meat probe
- Steam recovery cycle
- Combined cooking
- CLEAN assisted cleaning cycle
- 3-pane glass cool-touch door

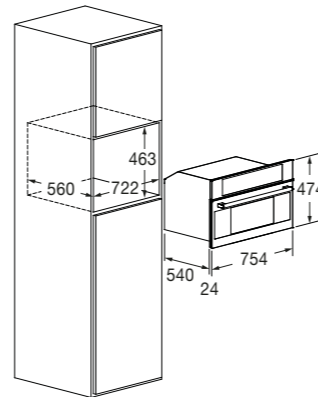

**Features**

The 30" combined steam oven offers a 34-litres internal capacity and 12 versatile cooking functions, including combined cooking, AirFry mode, Steam Boost, and steam reheating. The intuitive Touch Control interface allows you to choose from preset cooking programs or to create and save customised recipes, providing maximum flexibility and precision in the kitchen. The standard accessory set includes a food temperature probe, a perforated tray with lid, a stainless-steel support for the perforated tray, a stainless-steel tray, a flat rack, and a water tank.

Accessories on request page 305  
 Technical data page 355



STAINLESS STEEL  
 FCSO 310 TEM X  
 EAN 8019801031122

BLACK GLASS  
 FCSO 310 TEM BK  
 EAN 8019801034215



**30" Combi Microwave Oven**

**FCMO 310 TEM X**



- Stainless steel finish
- 10 Combined functions
- AirFry (oven-frying) function
- Creative Extended controls
- Automatic Cooking
- Microwave with 6 power levels
- Cooking with assisted ventilation
- Combined cooking (microwave & grill)
- Defrosting
- 3-pane glass cool-touch door

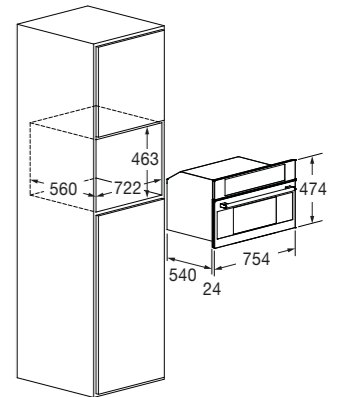

**Features**

The microwave in this collection combines innovation and versatility, integrating traditional cooking modes with microwave technology. The intuitive Touch Control allows you to easily select preset programs and to create and save customized recipes, ensuring maximum flexibility and precision in every preparation. The standard accessory set includes a turnable glass, a round rack, a flat rack, and an AirFry cooking tray.

Accessories on request page 305  
 Technical data page 355



STAINLESS STEEL  
 FCMO 310 TEM X  
 EAN 8019801031139

BLACK GLASS  
 FCMO 310 TEM BK  
 EAN 8019801034208



**XXL 90 Multifunction Oven**

FCO 9615 TEM 2F X



- Stainless steel finish
- 16 functions
- AirFry (oven-frying) function
- Creative Extended controls
- Meat probe
- Fast Pre-Heat BOOSTER
- Soft Closing
- Telescopic rails
- CLEAN assisted cleaning cycle
- 3-pane glass cool-touch door
- Energy Class A+

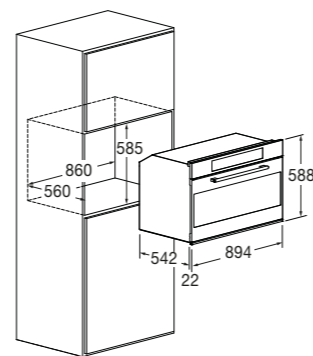

**Features**

The 90 cm multifunction oven is equipped with a practical Touch Control interface that allows you to easily select from numerous preset programs or customize new recipes according to your needs. The large 100-litre cavity enables simultaneous cooking of multiple dishes, while the dual-fan system ensures even heat distribution for uniform cooking results. Thanks to the Meat Probe, you can precisely monitor cooking by measuring the internal temperature of the food. The standard accessory set includes two telescopic guide sets, a temperature probe, an enamelled tray, a flat rack, a rotisserie kit, and an enamelled AirFry tray.

Accessories on request  
 Technical data

page 305  
 page 356



STAINLESS STEEL  
 FCO 9615 TEM 2F X  
 EAN 8019801030347

BLACK GLASS  
 FCO 9615 TEM 2F BK  
 EAN 8019801030354



**XL 90x48 Multifunction Oven**

FCO 9013 TM X



- Stainless steel finish
- 16 functions
- AirFry (oven-frying) function
- Creative controls
- Meat probe
- Fast Pre-Heat BOOSTER
- Soft Closing
- Telescopic rails
- CLEAN assisted cleaning cycle
- 3-pane glass cool-touch door
- Energy Class A+

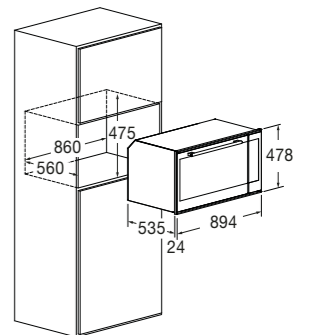

**Features**

The control panel has different functions, including preset cooking functions and the possibility to modify the recipes. With the Meat Probe, you can obtain perfect results because it allows you to monitor the cooking progress by measuring the food core temperature. This product comes with the following accessories: two sets of telescopic rails, a Meat Probe, an enamelled tray, a flat rack, a rotisserie kit and an enamelled AirFry tray.

Accessories on request  
 Technical data

page 305  
 page 356



STAINLESS STEEL  
 FCO 9013 TM X  
 EAN 8019801017362

BLACK GLASS  
 FCO 9013 TM BK/2  
 EAN 8019801030378



**XL 75 Multifunction Pyro Oven**

FCPO 7515 P TEM X



- Stainless steel finish
- 18 functions
- AirFry (oven-frying) function
- Creative Extended controls
- Meat probe
- Fast Pre-Heat BOOSTER
- Soft Closing
- Telescopic rails
- Pyrolytic self-cleaning oven
- 4-pane glass cool-touch door
- Energy Class A+

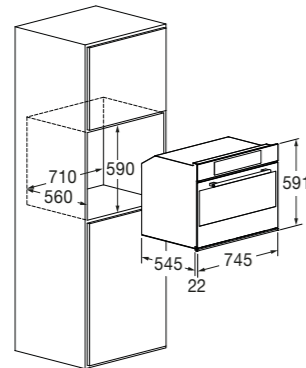

**Features**

Piro Pizza oven cooks pizza at 350 °C in three minutes (Pizza Pizzeria Function). The control panel has different functions, including preset cooking functions and the possibility to modify the recipes. With the Meat Probe, you can monitor the cooking progress by measuring the food core temperature. The oven's cavity is cleaned automatically, thanks to the pyrolytic self-cleaning function. This product comes with the following accessories: two sets of telescopic rails, a Meat Probe, an enamelled tray, a flat rack, an enamelled AirFry tray, and a pizza kit (round grill rack, shovel, and firestone).

Accessories on request page 305  
 Technical data page 357



STAINLESS STEEL  
 FCPO 7515 P TEM X  
 EAN 8019801037247



BLACK GLASS  
 FCPO 7515 P TEM BK  
 EAN 8019801037230



**XL 75 Multifunction Oven**

FCO 7515 TEM X



- Stainless steel finish
- 16 functions
- AirFry (oven-frying) function
- Creative Extended controls
- Meat probe
- Fast Pre-Heat BOOSTER
- Soft Closing
- Telescopic rails
- CLEAN assisted cleaning cycle
- 3-pane glass cool-touch door
- Energy Class A+

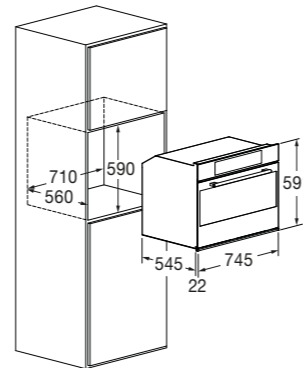

**Features**

Through the elegant and intuitive Touch Control, it is easy to select the preset programs and create and save personalized recipes, ensuring maximum flexibility and precision in every preparation. In the practical 75 cm size, this multifunction oven allows you to cook multiple dishes at the same time. Thanks to the Meat Probe, achieving perfect results is even simpler: you can check the cooking by measuring the internal temperature of the food. The standard accessories include two sets of telescopic guides, a temperature probe, an enamelled tray, a flat grill, a rotisserie kit, and an enamelled tray for AirFry.

Accessories on request page 305  
 Technical data page 357



STAINLESS STEEL  
 FCO 7515 TEM X  
 EAN 8019801023271



BLACK GLASS  
 FCO 7515 TEM BK  
 EAN 8019801023431



**Steam oven 75x45**

FCSO 7510 TEM X



- Stainless steel finish
- 11 functions
- AirFry (oven-frying) function
- Creative Extended controls
- Meat probe
- Steam cooking
- Combined cooking
- Steam recovery cycle
- CLEAN assisted cleaning cycle
- 3-pane glass cool-touch door
- Energy Class A++

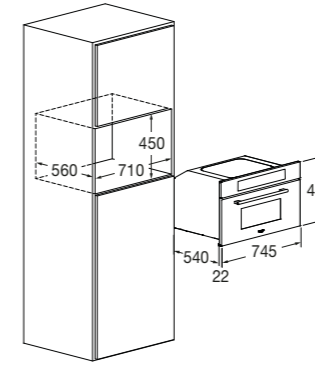

**Features**

The control panel has different functions, including preset cooking functions and the possibility to modify the recipes. With the Meat Probe, you can obtain perfect results because it allows you to monitor the cooking progress by measuring the food core temperature. This product comes with the following accessories: a meat probe, a perforated tray with lid, a stainless steel support for perforated tray, a stainless steel tray, a flat grill rack and a water tank.

Accessories on request page 305  
 Technical data page 358



STAINLESS STEEL  
 FCSO 7510 TEM X  
 EAN 8019801032242



BLACK GLASS  
 FCSO 7510 TEM BK  
 EAN 8019801032273



**Microwave oven 75x45**

FCMO 7510 TEM X



- Stainless steel finish
- 10 functions
- AirFry (oven-frying) function
- Creative Extended controls
- Automatic Cooking
- Combined cooking
- Microwave with 6 power levels
- Microwave & ventilation
- Microwave & grill
- Defrosting
- 3-pane glass cool-touch door

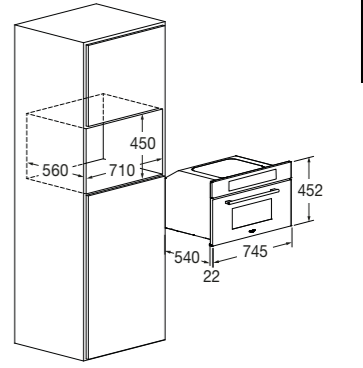

**Features**

The control panel has different functions, including preset cooking functions and the possibility to modify the recipes. Fulgor Milano combi oven is the solution to heat and cook food quickly, combining the advantages of a microwave oven with a traditional ventilated one. A complete and performing household appliance in a small space. With the microwave & ventilation function, you can cook golden brown dishes on the outside and well-cooked on the inside. This product comes with the following accessories: a glass turntable plate, a stainless steel tray, a flat grill rack and a round grill rack.

Accessories on request page 305  
 Technical data page 358



STAINLESS STEEL  
 FCMO 7510 TEM X  
 EAN 8019801032259



BLACK GLASS  
 FCMO 7510 TEM BK  
 EAN 8019801032280



**ATMOS Plano Steam Oven 60**

FCSO 6023 TEM X



- Stainless steel finish
- Classic Pizza Mode
- AirFry (oven-frying) function
- TFT touch control display
- 1300 ml water tank
- 11 classic cooking functions
- 6 steam cooking functions
- 7 special cooking functions
- Meat probe
- Soft Closing
- Energy Class A++

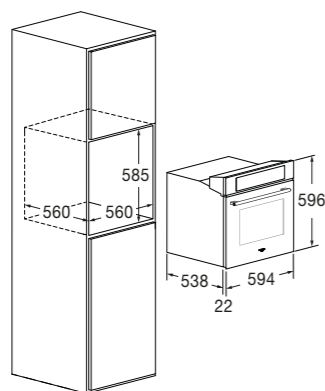

**Features**

Atmos steam oven has 24 cooking functions. Its control panel opens automatically to help you fill the water tank without opening the oven. Numerous recipes are available, even for prolonged cooking (up to 3 hours of continuous steam). Water level sensor and reset notice. Cavity and circuit cleaning and descaling functions. This product comes with the following accessories: fully removable telescopic rails, a Meat Probe, a stainless steel steam kit (perforated tray and surface with support), an AirFry tray, an enamelled tray, and a flat grill rack.

Accessories on request page 305  
 Technical data page 359



STAINLESS STEEL  
 FCSO 6023 TEM X  
 EAN 8019801032266



BLACK GLASS  
 FCSO 6023 TEM BK  
 EAN 8019801032297



**Multifunction Piro Pizza 60**

FCPO 6215 P TEM X



- Stainless steel finish
- 18 functions
- Pizza Pizzeria 350 °C function
- AirFry (oven-frying) function
- Pyrolytic self-cleaning oven
- Creative Extended controls
- Meat probe
- Fast Pre-Heat BOOSTER
- Soft Closing + Telescopic rails
- 4-pane glass cool-touch door
- Energy Class A+

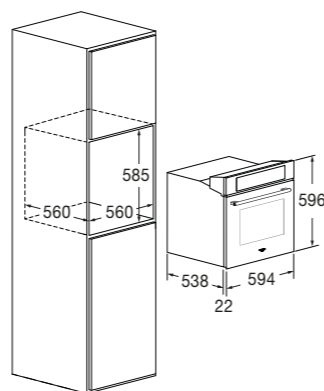

**Features**

Piro Pizza oven cooks pizza at 350 °C in three minutes (Pizza Pizzeria Function). The control panel has different functions, including preset cooking functions and the possibility to modify the recipes. With the Meat Probe, you can monitor the cooking progress by measuring the food core temperature. The oven's cavity is cleaned automatically, thanks to the pyrolytic self-cleaning function. This product comes with the following accessories: two sets of telescopic rails, a Meat Probe, an enamelled tray, a flat rack, an enamelled AirFry tray, and a pizza kit (round grill rack, shovel, and firestone).

Accessories on request page 305  
 Technical data page 360



STAINLESS STEEL  
 FCPO 6215 P TEM X  
 EAN 8019801027699



BLACK GLASS  
 FCPO 6215 P TEM BK  
 EAN 8019801027705



WHITE GLASS  
 FCPO 6215 P TEM WH  
 EAN 8019801027712



**Multifunction Oven 60**

FCO 6215 TEM X



- Stainless steel finish
- 16 functions
- AirFry (oven-frying) function
- Creative Extended controls
- Meat probe
- Fast Pre-Heat BOOSTER
- CLEAN assisted cleaning cycle
- Telescopic rails
- 3-pane glass cool-touch door
- Energy Class A++

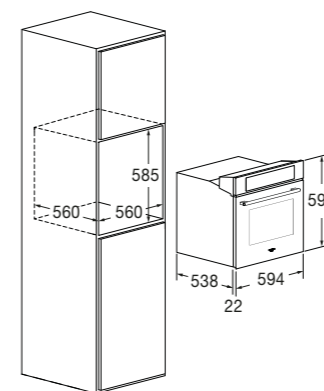

**Features**

The control panel has different functions, including preset cooking functions and the possibility to modify the recipes. With the Meat Probe, you can obtain perfect results because it allows you to monitor the cooking progress by measuring the food core temperature. This product comes with the following accessories: two sets of telescopic rails, a Meat Probe, an enamelled tray, a flat rack, a rotisseries kit and an enamelled AirFry tray.

Accessories on request page 305  
 Technical data page 361



STAINLESS STEEL  
 FCO 6215 TEM X  
 EAN 8019801027675



BLACK GLASS  
 FCO 6215 TEM BK  
 EAN 8019801027651



WHITE GLASS  
 FCO 6215 TEM WH  
 EAN 8019801027668



**Multifunction Oven 60**

FCOS 6215 TEM X



- Stainless steel finish
- 16 functions
- AirFry (oven-frying) function
- Creative Extended controls
- Meat probe
- Fast Pre-Heat BOOSTER
- Reversible side opening door
- CLEAN assisted cleaning cycle
- 3-pane glass cool-touch door
- Energy Class A++

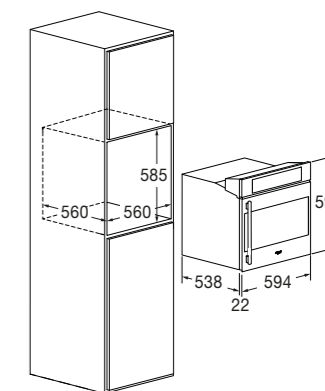

**Features**

The control panel has different functions, including preset cooking functions and the possibility to modify the recipes. With the Meat Probe, you can obtain perfect results because it allows you to monitor the cooking progress by measuring the food core temperature. This product comes with the following accessories: two sets of telescopic rails, a Meat Probe, an enamelled tray, a flat rack, a rotisseries kit and an enamelled AirFry tray.

Accessories on request page 305  
 Technical data page 361



STAINLESS STEEL  
 FCOS 6215 TEM X  
 EAN 8019801027682

# PLANO 45

**FULGOR**  
MILANO



PLANO

PLANO

**FULGOR**  
MILANO

# PLANO 45 STEAM OVEN

Steam cooking uses the power of humidity to transfer heat efficiently. Humidity prevents evaporation while maintaining the ingredients' flavours and texture. Moreover, steam cooking is sustainable because it uses low temperatures, saving time and energy.



Steam ovens cook food gently and healthily while preserving all the vitamins.

Besides having all traditional settings, Fulgor Milano's steam oven can add steam to the preparation.

Food cooks embraced in steam. The combination of heat and steam prevents humidity from evaporating, preserving the flavours and improving the texture of meat, fish, and vegetables.



The crust will always be brown and crispy, thanks to the mild and consistent heat, while the interior will cook just right every time. When water is heated to create steam, the heat penetrates the food faster and more deeply, reducing cooking times. This way, we use less energy while ensuring lower environmental impact.



**Combi Steam Oven 45**

FCSO 4510 TEM X



- Stainless steel finish
- 11 functions
- AirFry (oven-frying) function
- Creactive Extended controls
- Meat probe
- Steam cooking
- Combined cooking
- Steam recovery cycle
- CLEAN assisted cleaning cycle
- 3-pane glass cool-touch door
- Energy Class A++

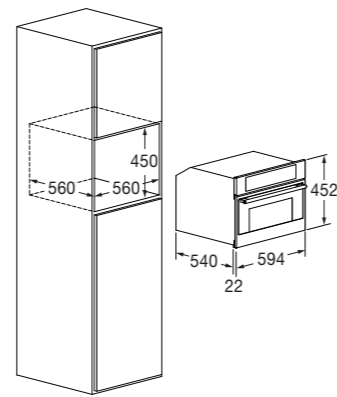

**Features**

Steam ovens cook food gently, healthily, and efficiently while preserving its organoleptic properties. The control panel has different functions, including preset steam cooking functions and the possibility to modify the recipes. With the Meat Probe, you can obtain perfect results because it allows you to monitor the cooking progress by measuring the food core temperature. This product comes with the following accessories: a meat probe, a perforated tray with lid, a stainless steel support for perforated tray, a stainless steel tray, a flat grill rack and a water tank.

Accessories on request  
 Technical data

page 305  
 page 362



STAINLESS STEEL  
 FC SO 4510 TEM X  
 EAN 8019801030569



BLACK GLASS  
 FC SO 4510 TEM BK  
 EAN 8019801030590



WHITE GLASS  
 FC SO 4510 TEM WH  
 EAN 8019801030637



# PLANO 45 MICROWAVE OVENS

FULGOR MILANO's microwave ovens stand out for the exclusive PLANO design. They make every cooking experience unique, ensuring reduced cooking times, a wide range of tasty preparations, and the possibility to choose three cooking modes. Available in three finishes: stainless steel, black or white glass.

## COOKING MODES AND FUNCTIONS

FULGOR MILANO microwave adds a range of other functions in addition to the traditional ones. So besides reduced cooking times, these ovens ensure grill and ventilated cooking in the combo version. The advantages of a microwave and traditional oven in a reduced space.

With the recipe function, you can cook meat, fish, and desserts following the guided settings designed by qualified chefs for FULGOR MILANO's microwave ovens. By selecting a menu item, the cooking mode, temperature, and time will be set automatically, based on the chosen recipe.



Thanks to the electronic CREATIVE EXTENDED system with a dual keyboard, you can easily select the function you want with a single touch.

The light inside the stainless steel cooking chamber allows you to check the cooking progress step-by-step without opening the door.

Moreover, the rectangular support rack, the round rack, the stainless steel tray, and the glass turntable plate are just a few of the FULGOR MILANO microwave oven's accessories.



**Combi Microwave Oven 45**

FCMO 4510 TEM X



- Stainless steel finish
- 10 Combined Functions
- AirFry (oven-frying) function
- Creative Extended controls
- Automatic Cooking
- Microwave with 6 power levels
- Microwave & ventilation
- Microwave & grill
- Defrosting
- 3-pane glass cool-touch door

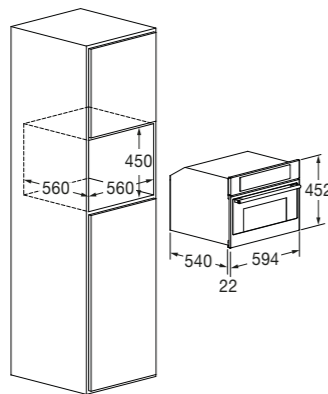

**Features**

The control panel has different functions, including preset cooking functions and the possibility to modify the recipes. Fulgor Milano combi oven is the solution to heat and cook food quickly, combining the advantages of a microwave oven with a traditional ventilated one. A complete and performing household appliance in a small space. With the microwave & ventilation function, you can cook golden broan dishes on the outside and well-cooked on the inside. This product comes with the following accessories: a glass turntable plate, a stainless steel tray, a flat grill rack and a round grill rack.

Accessories on request page 305  
 Technical data page 362



STAINLESS STEEL  
 FCMO 4510 TEM X  
 EAN 8019801030576

BLACK GLASS  
 FCMO 4510 TEM BK  
 EAN 8019801030613

WHITE GLASS  
 FCMO 4510 TEM WH  
 EAN 8019801030644



**Microwave and grill oven 45**

FGMO 4508 TEM X



- Stainless steel finish
- 5 functions
- Creative Extended controls
- Microwave with 6 power levels
- Microwave & grill
- Defrosting
- 3-pane glass cool-touch door

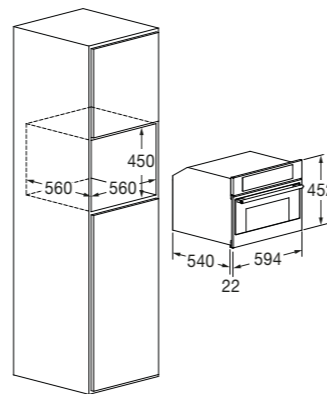

**Features**

FULGOR MILANO microwave oven is perfect for cooking and heating food and beverages. Thanks to the microwave & grill function, your dishes will be perfectly brown and crusty. The control panel has different functions, including preset cooking functions and the possibility to modify the recipes. This product comes with the following accessories: a glass turntable plate, a stainless steel tray, a flat grill rack and a round grill rack.

Accessories on request page 305  
 Technical data page 363



STAINLESS STEEL  
 FGMO 4508 TEM X  
 EAN 8019801023257

BLACK GLASS  
 FGMO 4508 TEM BK  
 EAN 8019801030606

WHITE GLASS  
 FGMO 4508 TEM WH  
 EAN 8019801030651

**FULGOR**  
 MILANO



# PLANO 45 COFFEE MACHINE



## YOUR PERSONAL BARISTA

Entirely manufactured in Italy, our professional coffee machines store and grind coffee beans and grounds, making the best coffee. It also runs a scheduled cleaning cycle. Enjoy the best Italian coffee, whether espresso, long coffee or cappuccino. This extraordinary coffee machine perfectly complements your Fulgor Milano kitchen appliances. With its different finishes, it perfectly combines with other PLANO products.

## EXTENDED PERFORMANCE

In addition to the standard coffee varieties (extra strong, strong, medium, light, and very light), this remarkable product includes a "cappuccinatore" (cappuccino maker). A great solution if you like a frothy cappuccino for breakfast. The integrated grinding technology allows you to enjoy your favourite coffee. All you have to do is to place one or two cups under the nozzles and wait a few seconds for the coffee to be ready. Moreover, thanks to the hot water and steam nozzle, you can make delicious teas, herbal teas and infusions. The appliance comes with the rinse function to ensure maximum hygiene.



## Built-In Coffee machine 45

FCM 4500 TF X



- Stainless steel finish
- 30 functions
- TFT touch control display
- Automatic programs
- Coffee bean container (200 g)
- Integrated and adjustable grinding
- Milk container
- Water container (1.8 l)
- Removable hot water dispenser
- Liquid collection container
- Five types of cup

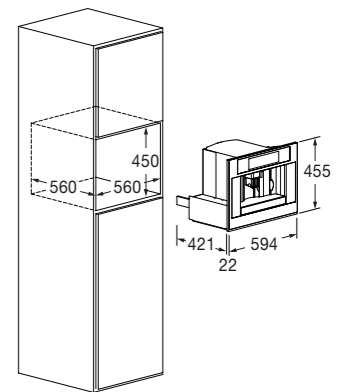

## Features

This product's design features a user-friendly touch control and digital display. Possibility to choose the type of coffee (e.g. long, short, light or strong) and make teas and herbal teas thanks to the automatic cappuccino maker and the hot water dispenser. The water hardness can also be adjusted. This system can be put on standby to save electricity. Moreover, it is fitted with a safety system, i.e. a warning light to indicate the absence of water or coffee and when it is time to run the cleaning cycle and replace the anti-scale filter. A telescopic opening gives access to the service compartment.

Technical data

page 365



STAINLESS STEEL  
FCM 4500 TF X  
EAN 8019801026197



BLACK GLASS  
FCM 4500 TF BK  
EAN 8019801025077



WHITE GLASS  
FCM 4500 TF WH  
EAN 8019801030675

# PLANO 45 BLAST CHILLER



Fulgor Milano's blast chiller is fitted with 11 functions and has a wide range of temperatures (from + 75 °C to -30 °C).

This excellent home appliance stores food better and for longer. It quickly takes the food's temperature to 3 °C, blocking bacteria proliferation without altering its nutritional and organoleptic properties. This way, food can be stored in the refrigerator for a week and still be as fresh as the day you bought it.

A blast chiller is practical for preparing a dessert or quickly cooling down a preparation without wasting food. In addition, blast-chilled leftovers can be stored in the refrigerator for longer. For example, this function allows you to cook and shop once a week and have a homemade dish ready in the fridge without it rotting. You can also stock up on seasonal ingredients (when

they are less expensive) and carefully store them for later use. Besides cooling down your preparations, the blast chiller frosts food, preventing ice crystals. Therefore, it's highly convenient to freeze portions to keep them ready to consume at any time. FULGOR MILANO's blast chillers can cook meat, eggs, fish, and vegetables at low temperatures. This way, you can slow-cook exquisite recipes, leaven doughs at controlled temperature and humidity, and defrost food naturally.



## Blast chillers 45

**FBC 4500 TF X**



- Stainless steel finish
- 11 functions
- TFT touch control display
- Blast chilling temperature +3°C
- Deep freezing -18°C
- Blast chilling temperature -30 °C (fresh fish)
- Quick cooling
- Defrosting
- Slow Cooking
- Leavening

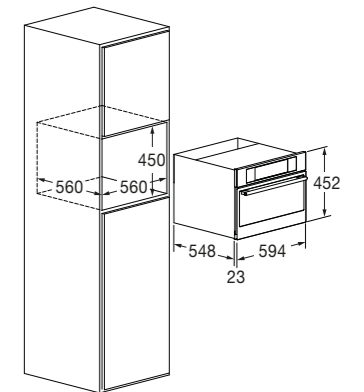

## Features

The blast chiller has a 40 l capacity. This appliance comes with the following accessories: a meat probe, a heat-resistant glass tray, and a rack. The best results are obtained with the vacuum sealing drawer enhancing the blast chiller functions. This appliance can be combined with the 45 and 60 cm ranges and Fulgor Milano's wide range of drawers.

Technical data

page 363



STAINLESS STEEL  
FBC 4500 TF X  
EAN 8019801016822



BLACK GLASS  
FBC 4500 TF BK  
EAN 8019801019755



WHITE GLASS  
FBC 4500 TF WH  
EAN 8019801019762

**FULGOR**  
MILANO

*IN VINO VERITAS  
IN WINE, THERE IS TRUTH*

(Pliny the Elder)



**WINE CELLAR 45**

# PLANO 45 WINE CELLAR



## STORE YOUR WINE IN A BETTER WAY

Our wine cellars are perfect for storing your wine. You can set the storage temperature based on the type of wine, with a thermal condition that ranges between 5 °C and 20 °C. The cellar has 3 levels made of untreated wood and can hold 22 bottles. The highest level is dedicated to bottles with a larger diameter, whereas the other two shelves can contain bottles with a smaller diameter. An anti-vibration system ensures that the sediment inside the bottle settles properly at the bottom. On the other hand, the anti-condensation system allows you to store the wine for longer since humidity ranges between 60% and 80%.

## EXTENDED PERFORMANCE

The electronic touch control system allows you to customise the storage conditions inside the cellar. Moreover, the insulated door glass shields UV rays, thanks to the appropriate filter.

Wine cellars are fitted with telescopic rails where the shelves slide to ensure immediate and easy access to the bottles. Moreover, the interior is evenly illuminated with LED lights to prevent overheating and enhance the beauty of your wine collection.



## Wine Cellar 45

FWC 4500 TC FO X



- Stainless steel finish
- Digital touch display
- Drop-down door
- Adjustable temperature between 5 and 20 °C
- Capacity: 22 Ø 76 mm bottles
- Telescopic rails
- Soft Closing

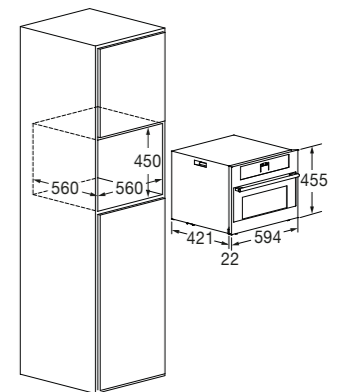

## Features

FULGOR MILANO's wine cellars are ideal for storing wine. You can set the storage temperature based on the type of wine, with a thermal condition that ranges between 5 °C and 20 °C. Temperature is adjusted using the user-friendly Touch Control system. Moreover, the cellar is equipped with antivibration and anticondensation systems and a UV-insulating glass pane. Internal LED lighting. The cellar's door is fitted with a SOFT CLOSING system that slows the closing movement. This appliance comes with the following accessories: 3 beech wood sliding champagne shelves (4 bottles).

Technical data

page 364



STAINLESS STEEL  
FWC 4500 TC FO X  
EAN 8019801032303



BLACK GLASS  
FWC 4500 TC FO BK  
EAN 8019801032310



WHITE GLASS  
FWC 4500 TC FO WH  
EAN 8019801032327



**Storage drawer 15**

FD 150 X

- Stainless steel structure
- 15 cm high front panel
- Anti-slip rubber mat



**Gas hob 90**

FPH 905 G WK X

- Stainless steel structure
- Electric ignition under the knob
- Burners with brass flame spreader

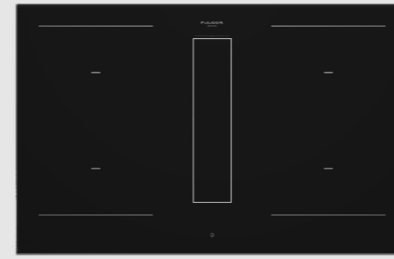

**Aria+ Induction Hob 80**

FHH 800 ID TC BK

- Black Glass Ceramic finish
- Multifunction Touch Control
- 4 cooking zones (2 vertical bridge zones)



**Lift Hood 90**

FDDH 900 TRC X

- Stainless steel finish
- 4 suction levels
- LED bar lighting



**Warming drawer 15**

FWD 150 X

- Stainless steel structure
- 15 cm high front panel
- Adjustable thermostat



**Gas hob 90**

FPH 9041 G WK X

- Stainless steel structure
- Electric ignition under the knob
- Burners with brass flame spreader



**Induction hob 90**

FSH 905 ID WT BK

- Black Glass Ceramic finish
- WAVE Touch Slider controls
- 5 cooking zones



**Wall-mounted hood 90**

FTHD 900 TC X

- Stainless steel finish
- Touch controls
- 4 suction levels

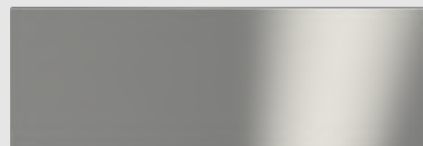

**Warming drawer 27**

FWD 3024 X

- Stainless steel finish
- 27 cm high front panel
- Adjustable thermostat



**Gas hob 75**

FPH 755 G WK X

- Stainless steel structure
- Electric ignition under the knob
- Burners with brass flame spreader



**Induction hob 80**

FSH 804 ID WT BK

- Black Glass Ceramic finish
- WAVE Touch Slider controls
- 4 cooking zones



**Integrated hood 85**

FBGHD 850 TC X

- Stainless steel finish
- Touch controls
- 4 suction levels





**Storage drawer 15**

**FD 150 WH**

- White Glass finish
- 15 cm high front panel
- Anti-slip rubber mat

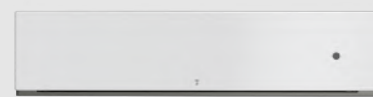

**Warming drawer 15**

**FWD 150 WH**

- White Glass finish
- 15 cm high front panel
- Adjustable thermostat



**Gas hob 90**

**FPH 905 G WK WHG**

- White Glass finish
- Electric ignition under the knob
- Burners with brass flame spreader



**Gas hob 75**

**FPH 755 G WK WHG**

- White Glass finish
- Electric ignition under the knob
- Burners with brass flame spreader



**Gas hob 60**

**FPH 604 G WK WHG**

- White Glass finish
- Electric ignition under the knob
- Burners with brass flame spreader

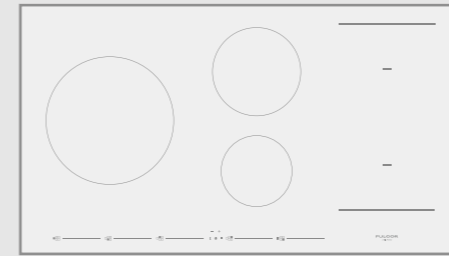

**Induction hob 90**

**FSH 905 ID TS WH 1**

- White Glass Ceramic finish
- Touch Slider controls
- 5 cooking zones (vertical bridge zone)

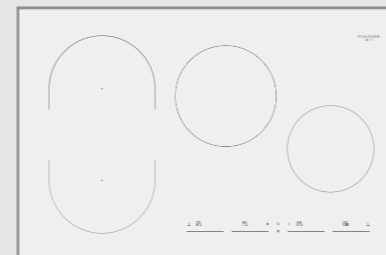

**Induction hob 80**

**FSH 804 ID TS WH 1**

- White Glass Ceramic finish
- Touch Slider controls
- 4 cooking zones (vertical bridge zone)



**Induction hob 80**

**FCH 804 ID TS WH**

- White Glass Ceramic finish
- Touch Slider controls
- 4 cooking zones (2 vertical bridge zones)



**Lift Hood 90**

**FDDH 900 TRC WH**

- White Glass finish
- Touch controls and remote control
- 4 suction levels



**Wall-mounted hood 90**

**FTHD 900 TC WH X**

- White Glass finish
- Touch controls
- 4 suction levels



**Island hood 90**

**FTIHD 960 TC WH X**

- White Glass finish
- Touch controls
- 4 suction levels



**FULGOR**  
MILANO

DRAWER  
**VACUUM SEALING**

A GENTLE PRESERVATION FOR  
AN EXCELLENT FLAVOR

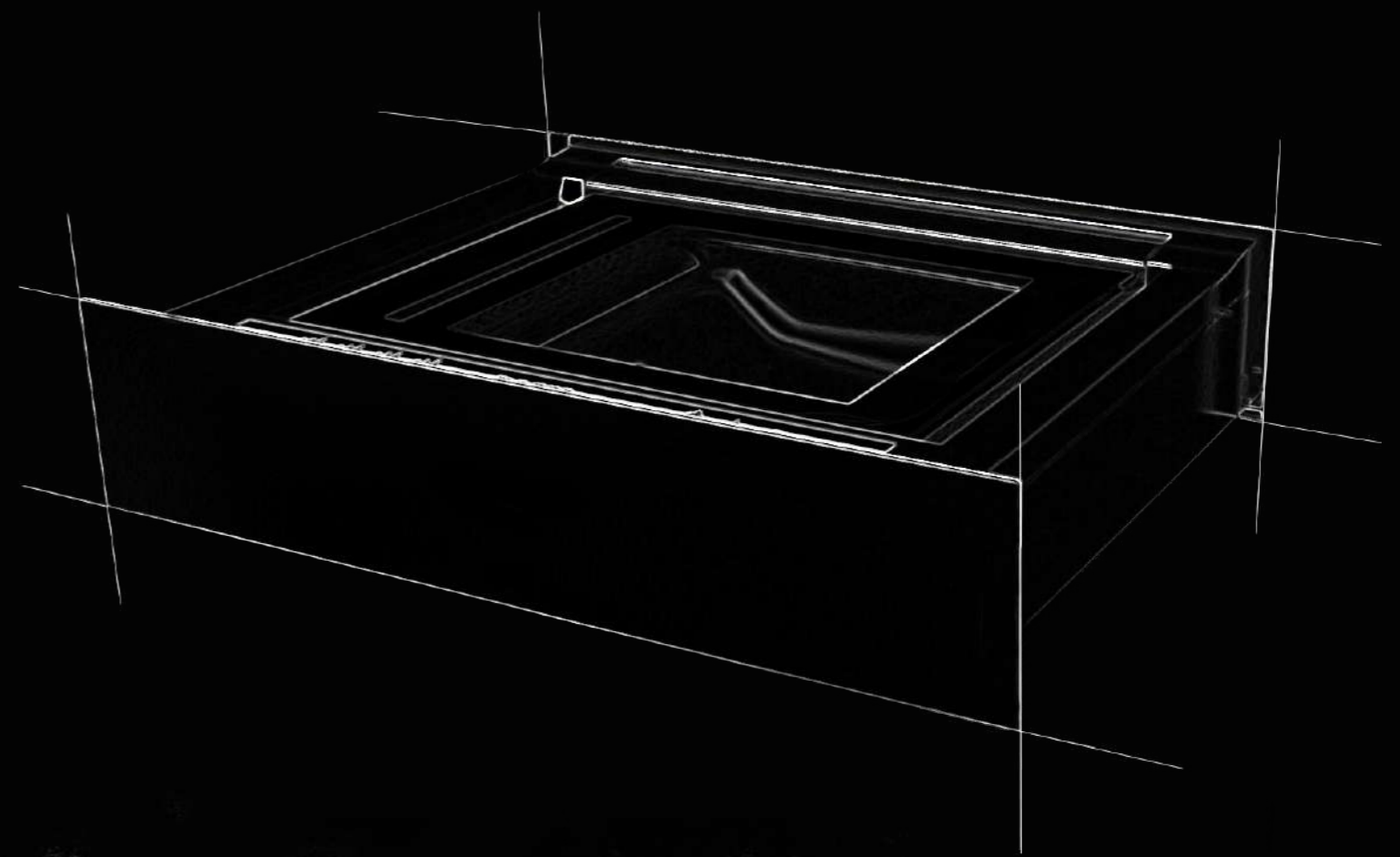

**FULGOR**  
MILANO

# VACUUM SEALING DRAWER



## COOKING AND STORING

Thanks to specific bags, the vacuum sealing drawer allows you to use the sous-vide technique to cook your recipes. This low-temperature technique cooks food homogeneously without dispersing its natural moisture. This way, food preserves its flavours and nutritional values whether you freeze, steam, or cook it at low temperatures, obtaining excellent results. This appliance is fitted with the special Chef function for marinating, ripening, and cold infusion processes. Traditional appliances take 24-72 hours to complete the marinating process. Fulgor Milano's vacuum sealing drawers take only 8-12 minutes. Moreover, it's ideal for massaging fish and meat and preparing sauces, gravies and concentrates.

**FULGOR**  
MILANO



## TECHNICAL FEATURES

Our vacuum sealing drawer has several programs to meet every need. These programs include: vacuum cycle for cooking, vacuum cycle in containers, short vacuum cycle in containers, long vacuum cycle in containers outside the chamber, and energy saving. You can select these functions from a user-friendly touchscreen. Inside the appliance, you'll find the vacuum chamber and the sealing bar, which suctions the air, whereas the locking system ensures the bag's integrity. The glass cover makes it easier to see inside.

## VACUUM CYCLE IN CONTAINERS

If you opt for the short cycle, you can obtain 80% vacuum sealing using polycarbonate containers. On the other hand, if you run the long cycle using a rigid vacuum sealing container (glass, for example), you'll obtain 100% vacuum sealing.



### Vacuum sealing drawer 15

FVSD 150 TC X



- Stainless steel finish
- Touch control panel
- Push-to-open system
- Sealing bar (bags)
- Glass lid
- Stainless steel vacuum chamber
- Energy-saving function
- Chef function
- Vacuum cycle for storage + Vacuum cycle for cooking
- Pump oil dehumidification cycle
- Draw capacity volume 6.4 l

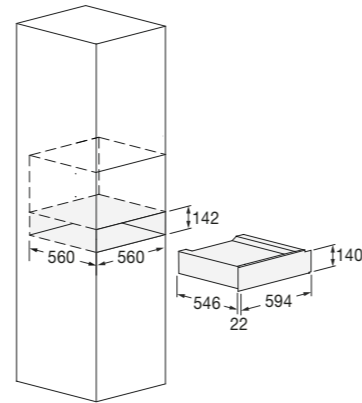

### Features

Thanks to specific bags, the vacuum sealing drawer allows you to use the sous-vide technique to cook your recipes. This low-temperature technique cooks food homogeneously without dispersing its natural moisture. This appliance is fitted with the Chef function for marinating, ripening, and cold infusion processes. Moreover, it's ideal for massaging fish and meat and preparing sauces, gravies and concentrates. The drawer runs vacuum cycles in containers and short or long vacuum cycles outside the draw container.

This product can be combined with other appliances from the 45 cm and 60 cm range.

Technical data

page 366



STAINLESS STEEL  
FVSD 150 TC X  
EAN 8019801019922

BLACK GLASS  
FVSD 150 TC BK  
EAN 8019801019939

WHITE GLASS  
FVSD 150 TC WH  
EAN 8019801019946

DEEP BLACK GLASS  
FCLVSD 150 TC BK  
EAN 8019801019953

MATTE BLACK METAL  
FUTVSD 150 TC MBK  
EAN 8019801035915



### Vacuum sealing drawer 29

FVSD 2900 TC



- Overlay panels
- Touch control panel
- Sealing bar
- Glass lid
- Vacuum chamber container
- Energy-saving function
- Pump oil dehumidification cycle
- Draw capacity volume 7.65 l

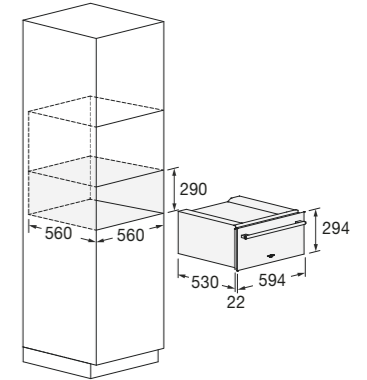

### Features

Thanks to specific bags, the vacuum sealing drawer allows you to use the sous-vide technique to cook your recipes. This low-temperature technique cooks food homogeneously without dispersing its natural moisture. This appliance is fitted with the Chef function for marinating, ripening, and cold infusion processes. Moreover, it's ideal for massaging fish and meat and preparing sauces, gravies and concentrates. The drawer increases the food's storage time. It runs a vacuum cycle for storing and cooking food in bags, short and long vacuum cycles in containers, and vacuum cycles for jars outside the draw container. This product can be combined with other products from the 45 cm and 60 cm range. The vacuum sealing drawer's structure is made with panels. A stainless steel panel kit with a handle (code FT 29 X) is available on request.

Technical data

page 366



PANEL-READY  
FVSD 2900 TC  
EAN 8019801019496

STEEL PANEL + HANDLE  
FT 29 X  
EAN 8019801019502

**FULGOR**  
MILANO

# FOOD WARMER DRAWER

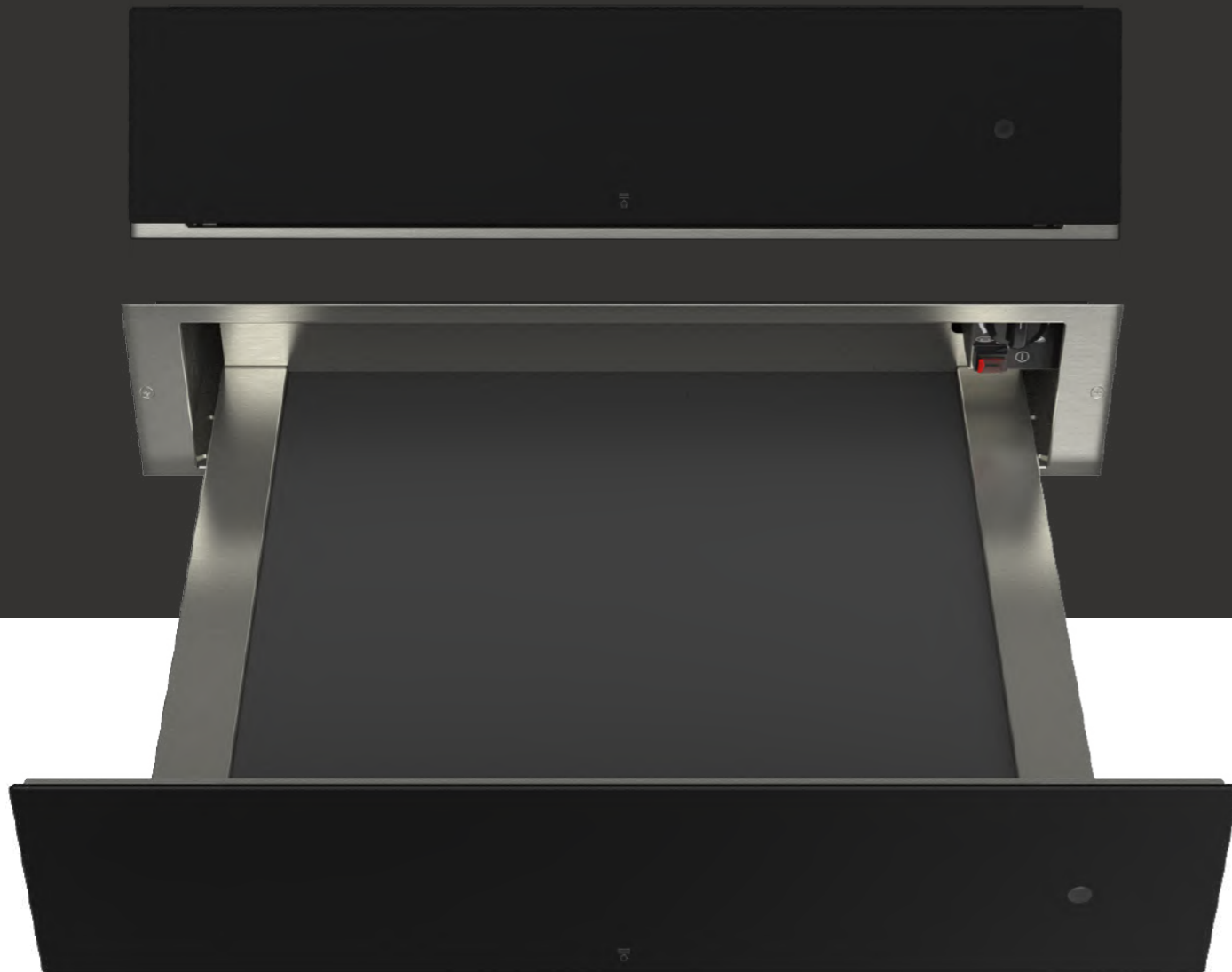

The warming drawer is fitted with tangential ventilation that distributes heat evenly inside the cavity. Setting the temperature through the knob is easy and intuitive. A silicon mat at the bottom prevents dishes from moving in the drawer when you open and close it. The food warmer drawer is available in Deep Black Glass, White glass, Black Glass, Matt Black and Stainless steel. The 60 l stainless steel drawer is the solution if you're looking for larger spaces. The food warmer drawer is available in Deep Black Glass, White glass, Black Glass, Matt Black and Stainless steel. The 60 l stainless steel drawer is the solution if you're looking for larger spaces.



## Warming drawer 15

**FWD 150 X**



- Stainless steel finish
- 15 cm high front panel
- Push-to-open system
- Fully removable
- Ventilated
- Warm food function
- Defrosting
- Leavening
- Slow cooking up to 70 °C
- Dishes and coffee cups pre-heating

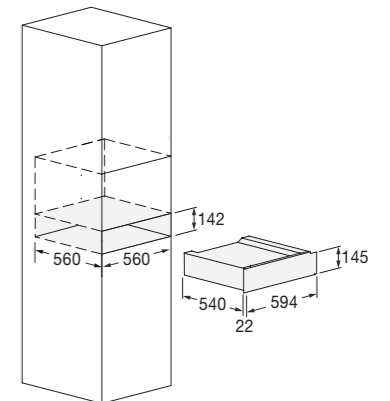

## Features

The drawer features internal ventilation, an adjustable thermostat (from 30 °C to 70 °C) and an operation indicator light. This appliance comes with a anti-slip rubber mat. Moreover, it can be combined with other products from the 45 cm and 60 cm range

Technical data

page 367



STAINLESS STEEL  
FWD 150 X  
EAN 8019801031801



BLACK GLASS  
FWD 150 BK  
EAN 8019801031436



WHITE GLASS  
FWD 150 WH  
EAN 8019801031443



DEEP BLACK GLASS  
FCLWD 150 BK  
EAN 8019801023196



MATTE BLACK METAL  
FUWD 150 MBK  
EAN 8019801029297



### Warming drawer 30

FWD 3024 X



- Manual controls
- 27 cm high front panel
- Internal capacity: 60 litres
- Push-to-open system
- Plates and cups heating
- Warm food function
- Defrosting
- Leavening
- Slow cooking up to 85 °C
- Telescopic rails

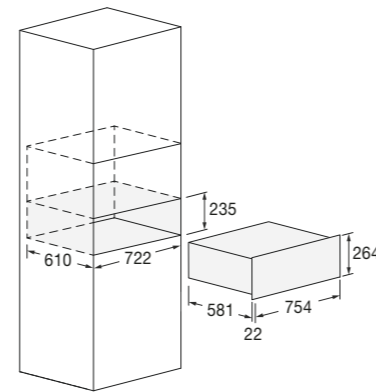

### Features

The drawer features internal ventilation, an adjustable thermostat (from 30 °C to 85 °C) and two lights. This appliance comes with a anti-slip rubber mat. This product can be combined with other products from the 45 cm and 60 cm range.

Technical data

page 367



STAINLESS STEEL  
FWD 3024 X  
EAN 8019801031214



BLACK GLASS  
FWD 3024 BK  
EAN 8019801034772



MATTE BLACK METAL  
FWD 3024 MBK  
EAN 8019801035038



### Warming drawer 74,5

FUTWD 7527 IX



- Manual controls
- 27 cm high front panel
- Internal capacity: 60 litres
- Push-to-open system
- Plates and cups heating
- Warm food function
- Defrosting
- Leavening
- Slow cooking up to 85 °C
- Telescopic rails

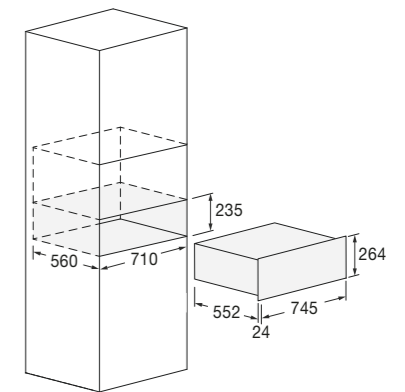

### Features

The drawer features internal ventilation, an adjustable thermostat (from 30 °C to 85 °C) and two lights. This appliance comes with a anti-slip rubber mat.

Technical data

page 368



STAINLESS STEEL  
FUTWD 7527 IX  
EAN 8019801034789



BLACK GLASS  
FUTWD 7527 GBK  
EAN 8019801037186



MATTE BLACK METAL  
FUTWD 7527 MBK  
EAN 8019801034796



DEEP BLACK GLASS  
FCLWD 7527 BK  
EAN 8019801037216

**FULGOR**  
MILANO

# STORAGE DRAWER

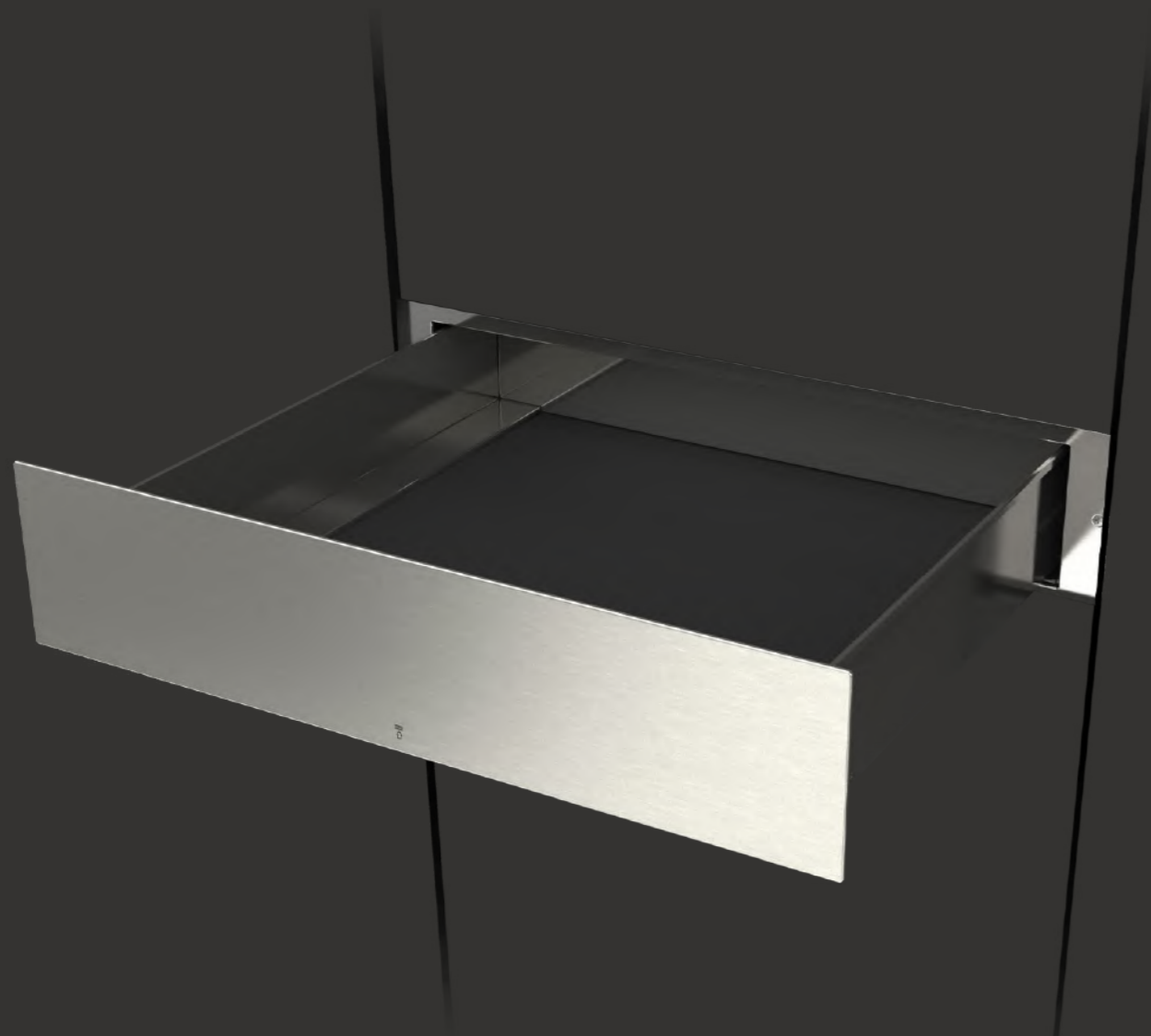

The storage drawer is fitted with a push/pull system and telescopic rails that make it easier to open, close and remove. A silicon mat at the bottom prevents kitchenware from moving in the drawer when you open and close it. Moreover, this mat can be removed and washed.

## DRAWERS

STORAGE



### Storage drawer 15

FD 150 X



- Stainless steel finish
- 15 cm high front panel
- Push-to-open system
- Telescopic rails
- Anti-slip rubber mat

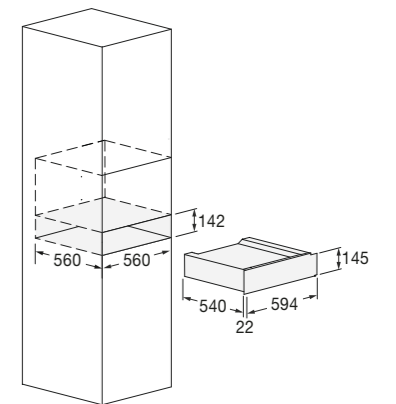

### Features

This product's design features a user-friendly touch control and digital display. Possibility to choose the type of coffee (e.g. long, short, light or strong) and make teas and herbal teas thanks to the automatic cappuccino maker and the hot water dispenser. The water hardness can also be adjusted. This system can be put on standby to save electricity. Moreover, it is fitted with a safety system, i.e. a warning light to indicate the absence of water or coffee and when it is time to run the cleaning cycle and replace the anti-scale filter. A telescopic opening gives access to the service compartment.

Technical data

page 368



STAINLESS STEEL  
FD 150 X  
EAN 8019801031818



BLACK GLASS  
FD 150 BK  
EAN 8019801031450



WHITE GLASS  
FD 150 WH  
EAN 8019801031467



DEEP BLACK GLASS  
FCLD 150 BK  
EAN 8019801023189



MATTE BLACK METAL  
FUD 150 MBK  
EAN 8019801030668

**FULGOR**  
MILANO

THE FREEDOM OF COOKING  
WITHOUT ODOURS

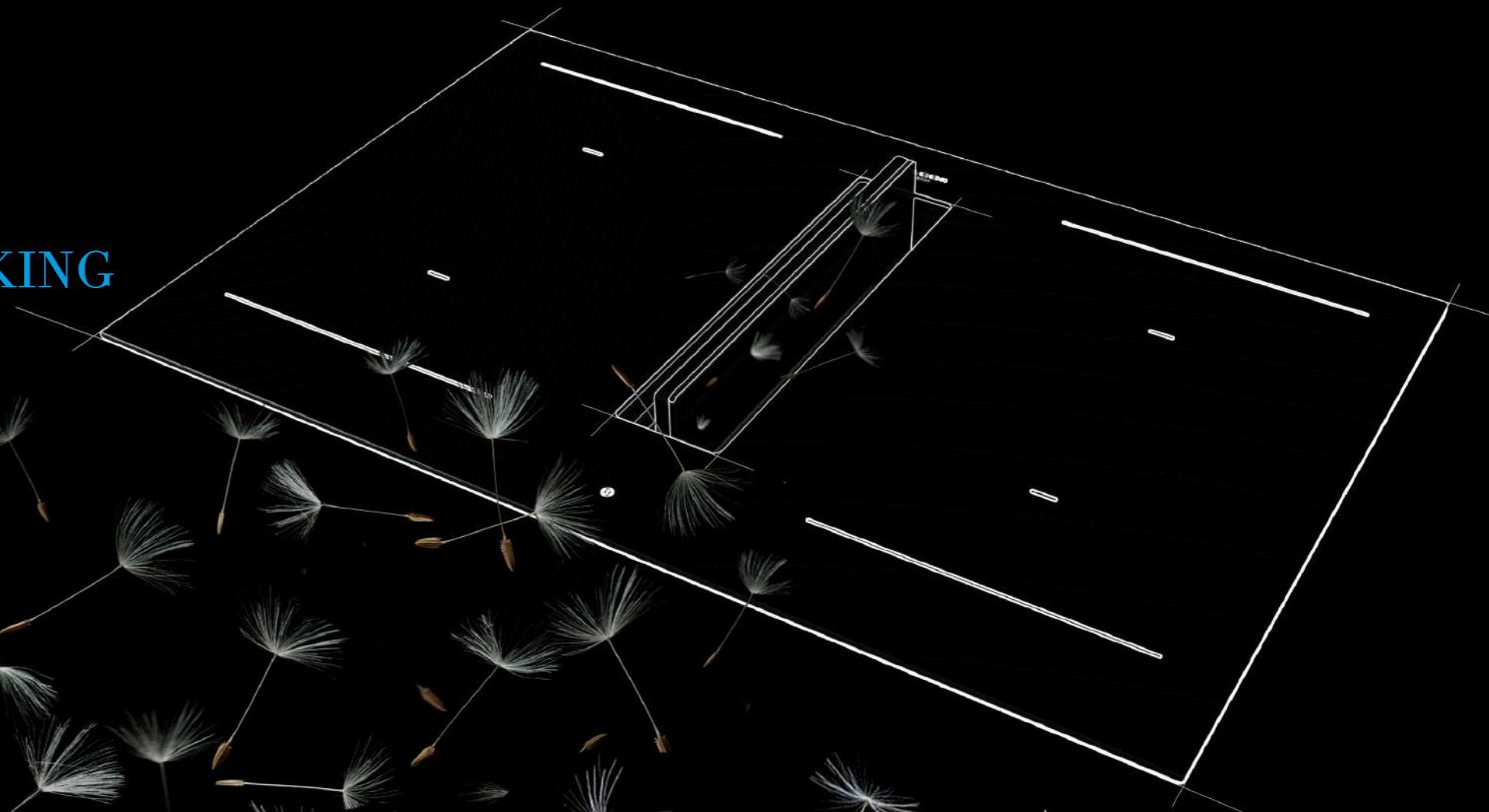

INDUCTION HOBS **ARIA+**

# ENOVA INDUCTION HOBS

The ENOVA cooktop is the result of a significant evolution of the traditional induction cooktop, distinguished by the introduction of new shapes, finishes, and volumes. The new models in the ENOVA Line showcase Fulgor Milano's advanced technological and stylistic research. The generous dimensions of the cooktop and the linear layout of the cooking zones ensure maximum space and freedom of movement, making it ideal for true cooking enthusiasts. The innovative and advanced induction system delivers high performance, safety, and reliability, enhanced by intuitive and professional-style knob controls.



**FULGOR**  
MILANO

# ENOVA INDUCTION HOBS

The cooktop features five highly functional cooking zones. The central zone, equipped with the Dual Max Power system, allows power to be evenly distributed across the entire surface, enabling the use of large cookware. The remaining four zones feature the Bridge function, allowing cooking zones to be seamlessly combined. Designed to meet contemporary interior design trends, ENOVA products by Fulgor Milano allow customers to easily customize the metal finishes of the control panel, trims, and knobs. The available finishes include Stainless Steel, Brass, and Anodized Black. The option to personalize these elements even after purchase, with exceptional ease for the user, allows for individual expression, offering a wide range of aesthetic combinations and enabling the cooktop to perfectly complement the style of any kitchen.

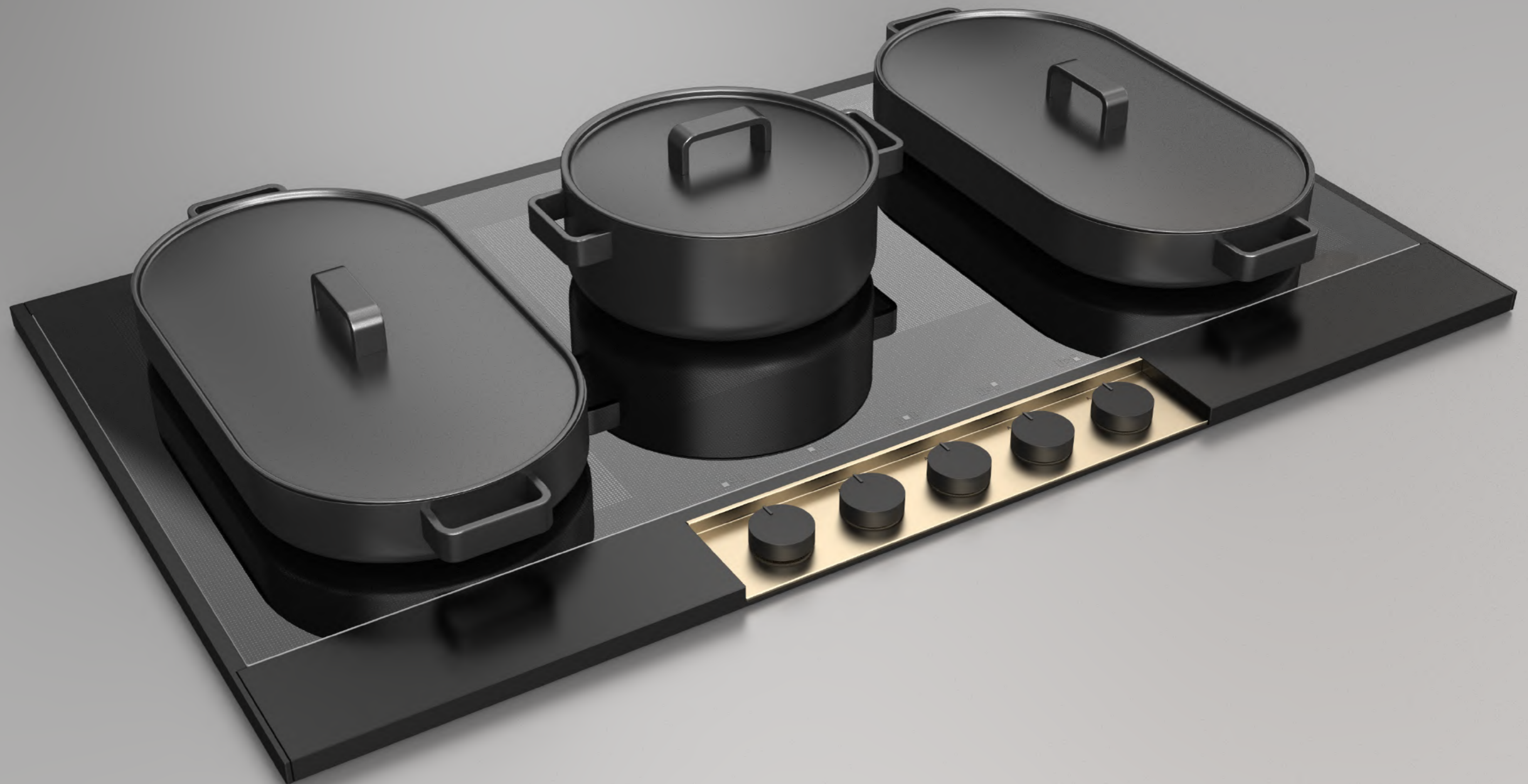

HOBS

HOBS



## Enova 120 Induction Hob

FEHCPK 4805 ID IX



- Stainless Finish
- Metal Control Knobs with Stainless Finish
- Glass Ceramic Surface
- 5 Cooking Zones (2 vertical bridge zones)
- Pan Detection Sensor
- 9 Power Levels
- BOOST Rapid Preheating
- Child Safety lock
- Keep Warm Function

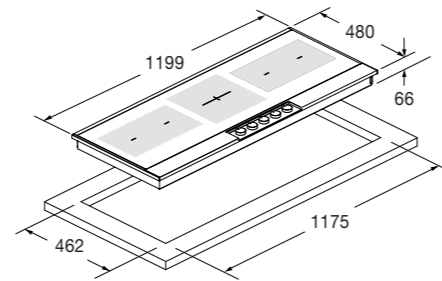

### Features

The Enova cooktop is the perfect blend of cutting-edge technology, sophisticated design, and maximum customization. Crafted from solid 15 mm satin-finished aluminum, it stands out for its elegant recessed knobs and interchangeable control panel and side trims, available in three premium finishes: matte black, brushed brass, and stainless steel. Powered by innovative Quantum induction technology, it guarantees high performance, reduced energy consumption, and fast, precise cooking. The cooktop features five cooking zones, each controlled via dedicated knobs, including a high-power 28 cm zone and two zones with a bridge system ideal for larger cookware. Each zone offers adjustable power levels from 1 to 9, along with dedicated functions such as Keep Warm, Rapid Heat, and BOOST. Thanks to its refined design and advanced professional functions, the Enova cooktop is the ideal choice for those seeking an appliance that combines aesthetics, performance, and top-level customization. The standard equipment includes the Enova Custom Metal Kit.

Technical data

page 370



STEEL FINISH  
FEHCPK 4805 ID IX  
EAN 8019801035335



MATTE BLACK ANODIZED  
FEHCPK 4805 ID MBK  
EAN 8019801035328



## Enova 120 Induction Hob

FEHK 4805 ID IX



- Stainless Finish
- Metal Control Knobs with Stainless Finish
- Glass Ceramic Surface
- 5 Cooking Zones (2 vertical bridge zones)
- Pan Detection Sensor
- 9 Power Levels
- BOOST Rapid Preheating
- Child Safety lock
- Keep Warm Function

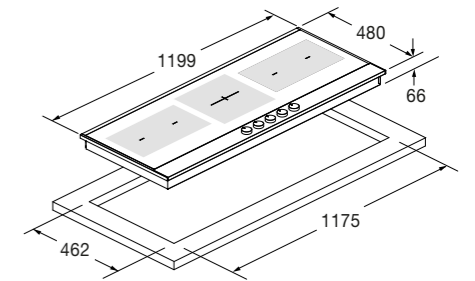

### Features

The Enova cooktop is the perfect blend of cutting-edge technology and sophisticated design. Crafted from solid 15 mm satin-finished aluminum, it stands out for its elegant recessed knobs. Powered by innovative Quantum induction technology, it guarantees high performance, reduced energy consumption, and fast, precise cooking. The cooktop features five cooking zones, each controlled via dedicated knobs, including a high-power 28 cm zone and two zones with a bridge system ideal for larger cookware. Each zone offers adjustable power levels from 1 to 9, along with dedicated functions such as Keep Warm, Rapid Heat, and BOOST. Thanks to its refined design and advanced professional functions, the Enova cooktop is the ideal choice for those seeking an appliance that combines aesthetics and performance.

Technical data

page 371



STEEL FINISH  
FEHK 4805 ID IX  
EAN 8019801035359



MATTE BLACK ANODIZED  
FEHK 4805 ID MBK  
EAN 8019801035342



### Enova 90 Induction Hob

FEHCPK 3605 ID IX



- Stainless Finish
- Metal Control Knobs with Stainless Finish
- Glass Ceramic Surface
- 5 Cooking Zones (2 vertical bridge zones)
- Pan Detection Sensor
- 9 Power Levels
- BOOST Rapid Preheating
- Child Safety lock
- Keep Warm Function

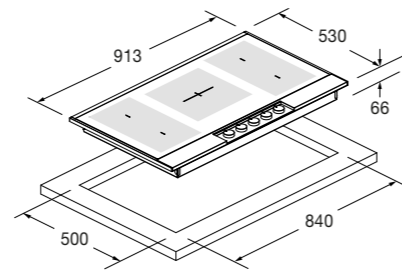

### Features

The Enova cooktop is the perfect blend of cutting-edge technology, sophisticated design, and maximum customization. Crafted from solid 15 mm satin-finished aluminum, it stands out for its elegant recessed knobs and interchangeable control panel and side trims, available in three premium finishes: matte black, brushed brass, and stainless steel. Powered by innovative Quantum induction technology, it guarantees high performance, reduced energy consumption, and fast, precise cooking. The cooktop features five cooking zones, each controlled via dedicated knobs, including a high-power 28 cm zone and two zones with a bridge system ideal for larger cookware. Each zone offers adjustable power levels from 1 to 9, along with dedicated functions such as Keep Warm, Rapid Heat, and BOOST. Thanks to its refined design and advanced professional functions, the Enova cooktop is the ideal choice for those seeking an appliance that combines aesthetics, performance, and top-level customization. The standard equipment includes the Enova Custom Metal Kit.

Technical data

page 372



STEEL FINISH  
FEHCPK 3605 ID IX  
EAN 8019801035373



MATTE BLACK  
FEHCPK 3605 ID MBK  
EAN 8019801035366



### Enova 90 Induction Hob

FEHK 3605 ID IX



- Stainless Finish
- Metal Control Knobs with Stainless Finish
- Glass Ceramic Surface
- 5 Cooking Zones (2 vertical bridge zones)
- Pan Detection Sensor
- 9 Power Levels
- BOOST Rapid Preheating
- Child Safety lock
- Keep Warm Function

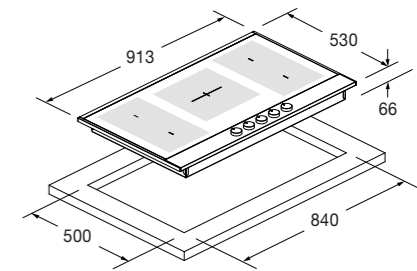

### Features

The Enova cooktop is the perfect blend of cutting-edge technology and sophisticated design. Crafted from solid 15 mm satin-finished aluminum, it stands out for its elegant recessed knobs. Powered by innovative Quantum induction technology, it guarantees high performance, reduced energy consumption, and fast, precise cooking. The cooktop features five cooking zones, each controlled via dedicated knobs, including a high-power 28 cm zone and two zones with a bridge system ideal for larger cookware. Each zone offers adjustable power levels from 1 to 9, along with dedicated functions such as Keep Warm, Rapid Heat, and BOOST. Thanks to its refined design and advanced professional functions, the Enova cooktop is the ideal choice for those seeking an appliance that combines aesthetics and performance.

Technical data

page 373



STEEL FINISH  
FEHK 3605 ID IX  
EAN 8019801035359



MATTE BLACK  
FEHK 3605 ID MBK  
EAN 8019801035380

**FULGOR**  
MILANO

# INDUCTION HOBS

## ARIA+

The continuous glass induction hob with built-in ARIA+ hood features an elegant and clean design. This suction surface includes 4 cooking zones with the Bridge function. Each zone features the Booster function and 9 power levels. With the Bridge function, you can use 4 single zones as 2 large vertical ones, ideal with large pans, griddles, or Teppanyaki grill plates. The Multifunction Touch Control includes several advanced functions, such as the Chef function, temperature maintenance function, and power limit function. Moreover, it manages both cooking and extraction functions.

ARIA+ is designed to be used in extraction or filtering mode, depending on the user's choice.

The versatile extraction hood is equipped with a solid glass-ceramic flap and 10 adjustment levels. Moreover, its waterproof extraction motor ensures an extraction power of 700 m<sup>3</sup>/h and a low noise level (62 dB). The state-of-the-art filtering section can be easily accessed from the top. It includes dishwasher-safe anti-grease filters and regenerable activated carbon filters. All these technologies allow ARIA+ to reach an A++ energy class.

ARIA+: Fulgor Milano's Design and Technology.



# INDUCTION HOBS

## ARIA+

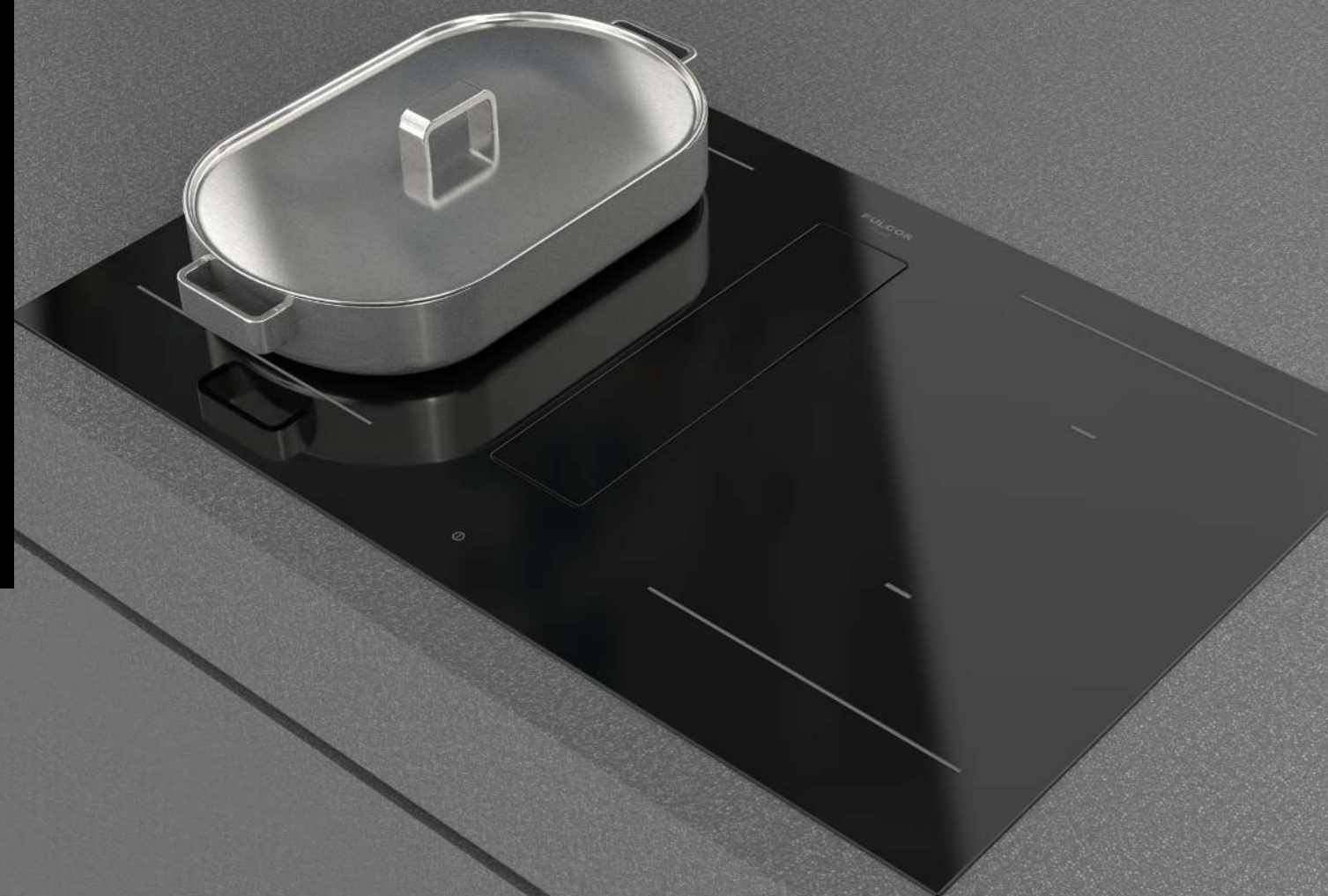

When Fulgor Milano's hob merges with the extraction hood, the result is Aria+. The kitchen acquires new dimensions. Daily movements are redesigned harmoniously, combining functionality, technology, and aesthetics. Kitchen odours are now a distant memory. The Aria+ extraction core ensures maximum efficiency and top performance, leaving you freedom of action. Moreover, it's ideal even for more complex preparations. The black glass-ceramic extraction surface stands out for its unique design. It is available in two sizes (80 and 60 cm) and features a multifunction touch control and high-efficiency filters ensuring professional performance.

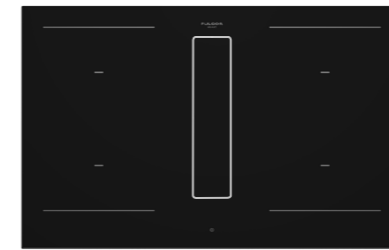

**ARIA+ induction 80**  
FHH 800 ID TC BK



- Multifunction Touch Control
- Black Glass Ceramic finish
- 4 cooking zones (2 vertical bridge zones)
- 9 power levels + Booster
- Chef function
- Temp. maintenance function
- Timer
- Power limit (optional)
- Built-In extraction hood
- Extraction booster
- Energy Class A++

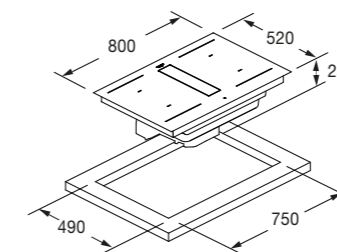

### Features

Induction hob with incorporated extraction hood equipped with a patented waterproof motor. One home appliance combining a high-performance hob with an efficient on-surface extraction. The Chef function allows you to differentiate the temperature of the cooking zones. Other functions include: adjustable delayed auto power off, grease filter maintenance warning, a light indicator for the regeneration of activated carbon ceramic filters, and automatic extraction hood power-off when the flap is closed. Moreover, this product comes with the following accessories: an anti-grease filter kit including a surface cleaning scraper. The tube kit and carbon filter kit are available on request:

Accessories on request page 311  
Technical data page 369



BLACK GLASS CERAMIC  
FHH 800 ID TC BK  
EAN 8019801032013



DUCT KIT  
FDUCTKIT ARIA+/2  
EAN 801980103273



CARBON FILTER KIT  
FCHF ARIA+  
EAN 801980103274

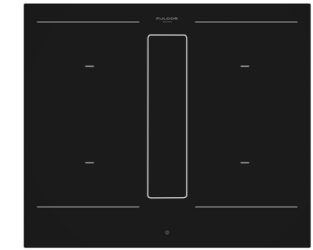

**ARIA+ induction 60**  
FHH 600 ID TC BK



- Multifunction Touch Control
- Black Glass Ceramic finish
- 4 cooking zones (2 vertical bridge zones)
- 9 power levels + Booster
- Temp. maintenance function
- Chef function
- Timer
- Power limit (optional)
- Built-In extraction hood
- Extraction booster
- Energy Class A++

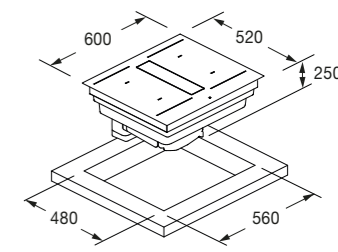

### Features

Induction hob with incorporated extraction hood equipped with a patented waterproof motor. One home appliance combining a high-performance hob with an efficient on-surface extraction. The Chef function allows you to differentiate the temperature of the cooking zones. Other functions include: adjustable delayed auto power off, grease filter maintenance warning, a light indicator for the regeneration of activated carbon ceramic filters, and automatic extraction hood power-off when the flap is closed. Moreover, this product comes with the following accessories: an anti-grease filter kit including a surface cleaning scraper. The tube kit and carbon filter kit are available on request:

Accessories on request page 311  
Technical data page 369



BLACK GLASS CERAMIC  
FHH 600 ID TC BK  
EAN 8019801032020



DUCT KIT  
FDUCTKIT ARIA+/2  
EAN 801980103273



CARBON FILTER KIT  
FCHF ARIA+  
EAN 801980103274



### Induction hob with extraction hood 90

FCLHD 9041 HID TS BK2



- Touch Slider controls
- Black Glass Ceramic finish
- 4 in-line cooking zones (2 horizontal bridge zones)
- 9 power levels + Booster
- Automatic pre-heating function
- Pre-Set: 40°, 70°, 90°C
- Energy Class A+

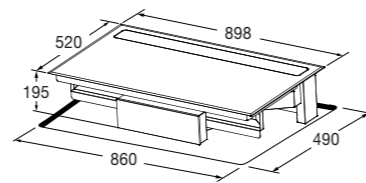

### Features

The induction hob with 4 in-line cooking zones (of which 2 horizontal bridge zones) includes a pan detection sensor, a control lock system, residual heat indicator (H) and automatic power-off with temperature sensor. Moreover, it includes a rear hood with an automatic Flap. Its suction capacity is equal to 645 m³/h and its sound power level ranges between 53 to 63 dBA. This product comes with FCHF 59 HP filter kit for the hood filtering version.

Accessories on request  
Technical data

page 311  
page 374



CERABLACK  
FCLHD 9041 HID TS BK2  
EAN 8019801022366



### Induction hob 90

FSH 905 ID WT BK



- WAVE Touch Slider controls
- Black Glass Ceramic finish
- 5 cooking zones
- Dual Max Power Ø 260 (3000-5500 W)
- Flexi zone (Automatic Bridge)
- 9 power levels + Booster
- Automatic pre-heating function
- Pre-Set: 40°, 70°, 90°C
- Timer

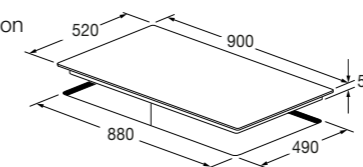

### Features

This hob features two concentric areas of various sizes and power, called DUAL MAX POWER. Therefore, it automatically adapts to pans of various sizes, making the cooking process extremely easy and comfortable. Safety is ensured by an articulated system that includes: a pan detection sensor, touch control lock, residual heat indicator (H) and automatic power-off with temperature sensor. It also comes with a surface cleaning scraper.

Technical data

page 375



BLACK GLASS CERAMIC  
FSH 905 ID WT BK  
EAN 8019801030743

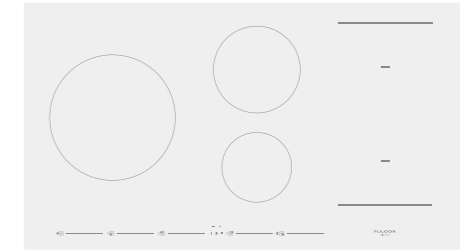

### Induction hob 90

FSH 905 ID TS WH 1



- Touch Slider controls
- White Glass Ceramic finish
- 5 cooking zones (vertical bridge zone)
- Ø 260 zone (2600-3700 W)
- 9 power levels + Booster
- Warm food function
- Pre-Set: 40°, 70°, 90°C
- Timer

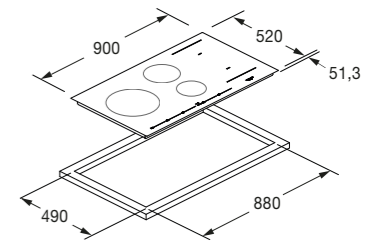

### Features

The hob features 5 cooking zones, of which one has a diameter of Ø 260 (2600-3700 W) on the left-hand side and a bridge zone to make it easier for you to arrange the pans on the hob. Other functions available: booster, timer, pan detection sensor, touch control lock, residual heat indicator (H) and automatic power-off with temperature sensor. It also comes with a surface cleaning scraper.

Technical data

page 376



WHITE GLASS CERAMIC  
FSH 905 ID TS WH 1  
EAN 8019801032563



**Induction hob 80**

FSH 804 ID WT BK



- WAVE Touch Slider controls
- Black Glass Ceramic finish
- 4 cooking zones
- Flexi zone (Automatic Bridge)
- 9 power levels + Booster
- Automatic pre-heating function
- Pre-Set: 40°, 70°, 90°C
- Timer

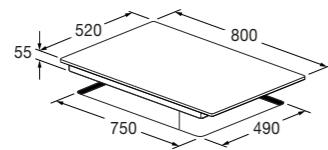

**Features**

This hob features two concentric areas of various sizes and power, called DUAL MAX POWER. Therefore, it automatically adapts to pans of various sizes, making the cooking process extremely easy and comfortable. Safety is ensured by an articulated system that includes: a pan detection sensor, touch control lock, residual heat indicator (H) and automatic power-off with temperature sensor. It also comes with a surface cleaning scraper.

Technical data

page 375



BLACK GLASS CERAMIC  
FSH 804 ID WT BK  
EAN 8019801030804

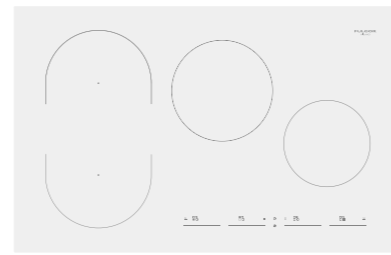

**Induction hob 80**

FSH 804 ID TS WH 1



- Touch Slider controls
- White Glass Ceramic finish
- 4 cooking zones (vertical bridge zone)
- 9 power levels + Booster
- Warm food function
- Pre-Set: 40°, 70°, 90°C
- Timer

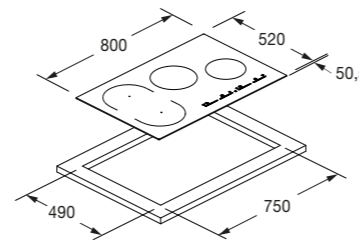

**Features**

The hob also features an articulated safety system that includes: a pan detection sensor, safety switch, residual heat indicator (H) and automatic power-off with temperature sensor. It also comes with a surface cleaning scraper.

Technical data

page 376



WHITE GLASS CERAMIC  
FSH 804 ID TS WH 1  
EAN 8019801032570



**Induction hob 40**

FSH 402 ID TS BK



- Touch Slider controls
- Black Glass Ceramic finish
- 2 cooking zones (vertical bridge zone)
- 9 power levels + Booster
- Automatic pre-heating function
- Pre-Set: 40°, 70°, 90°C
- Timer

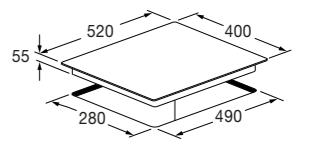

**Features**

The hob features 2 cooking zones with Bridge function. Other functions available: booster, timer, pan detection sensor, touch control lock, residual heat indicator (H) and automatic power-off with temperature sensor. It also comes with a surface cleaning scraper.

Technical data

page 377



BLACK GLASS CERAMIC  
FSH 402 ID TS BK  
EAN 8019801030842



WHITE GLASS CERAMIC  
FSH 402 ID TS WH  
EAN 8019801030767



### In-line induction hob 90

FCHL 904 ID TS BK



- Touch Slider controls
- Black Glass Ceramic finish
- 4 in-line cooking zones (2 horizontal bridge zones)
- 9 power levels + Booster
- Automatic pre-heating function
- Pre-Set: 40°C
- Power limit (optional)
- Timer

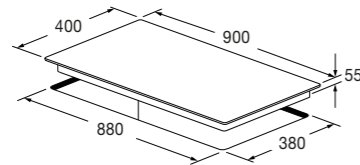

### Features

Induction hob featuring four in-line zones for easy use. With a 40° preset, you can set 40 °C to the chosen zone. The temperature will remain constant for the selected time (chocolate melting). The hob also features an articulated safety system that includes: a pan detection sensor, touch control lock, residual heat indicator (H) and automatic power-off with temperature sensor. It also comes with a surface cleaning scraper.

Technical data

page 379

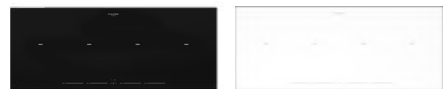

BLACK GLASS CERAMIC WHITE GLASS CERAMIC  
FCHL 904 ID TS BK FCHL 904 ID TS WH  
EAN 8019801032334 EAN 8019801032372

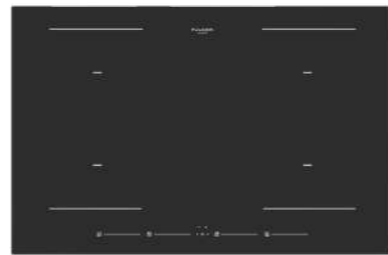

### Induction hob 80

FCH 804 ID TS BK



- Touch Slider controls
- Black Glass Ceramic finish
- 4 cooking zones (2 vertical bridge zones)
- 9 power levels + Booster
- Pause function
- Automatic pre-heating function
- Pre-Set: 40°C
- Power limit (optional)
- Timer

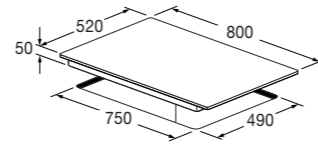

### Features

Hob with 4 cooking zones, including two vertical Bridge zones. Other functions available: pan detection sensor, touch control lock, residual heat indicator (H) and automatic power-off with temperature sensor. It also comes with a surface cleaning scraper.

Technical data

page 380



BLACK GLASS CERAMIC WHITE GLASS CERAMIC  
FCH 804 ID TS BK FCH 804 ID TS WH  
EAN 8019801032341 EAN 8019801032389

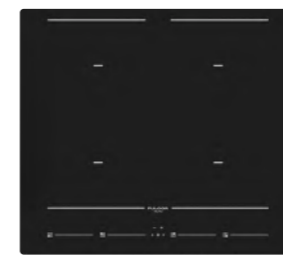

### Induction hob 60

FCH 604 ID TS BK



- Touch Slider controls
- Black Glass Ceramic finish
- 4 cooking zones (2 vertical bridge zones)
- 9 power levels + Booster
- Automatic pre-heating function
- Pre-Set: 40°, 70°, 90°C
- Power limit (optional)
- Timer

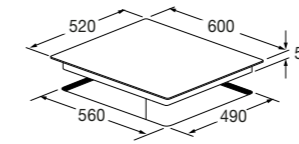

### Features

Hob with 4 cooking zones, including two vertical Bridge zones. Other functions available: pan detection sensor, touch control lock, residual heat indicator (H) and automatic power-off with temperature sensor. It also comes with a surface cleaning scraper.

Technical data

page 380



BLACK GLASS CERAMIC WHITE GLASS CERAMIC  
FCH 604 ID TS BK FCH 604 ID TS WH  
EAN 8019801032358 EAN 8019801032396

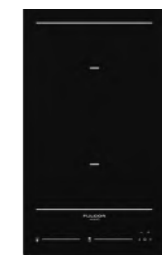

### Induction hob 30

FCH 302 ID TS BK



- Touch Slider controls
- Black Glass Ceramic finish
- 2 cooking zones (vertical bridge zone)
- Automatic pre-heating function
- Pre-Set: 40°C
- Pause function
- Timer

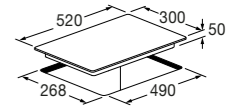

### Features

Hob with 2 cooking zones, including a vertical Bridge zone. Other functions available: pan detection sensor, touch control lock, residual heat indicator (H) and automatic power-off with temperature sensor. It also comes with a surface cleaning scraper.

Technical data

page 380



BLACK GLASS CERAMIC WHITE GLASS CERAMIC  
FCH 302 ID TS BK FCH 302 ID TS WH  
EAN 8019801032365 EAN 8019801032402

# INDUCTION HOBS

## MATTE BLACK

This Fulgor Milano hob range features a glass-ceramic surface with an exclusive Matte Black finish. It elegantly combines with products from the Urbantech range, which also stand out for their refined and essential aesthetics. The state-of-the-art induction technology produces heat super quickly, allowing you to adjust the power efficiently while saving energy. Thanks to the Dual Max Power system in the main inductor, you can adjust its power, making space for larger pans. Some models are fitted with the Flexi technology, allowing you to combine different cooking zones as if one. Maximum flexibility for the art of cooking.

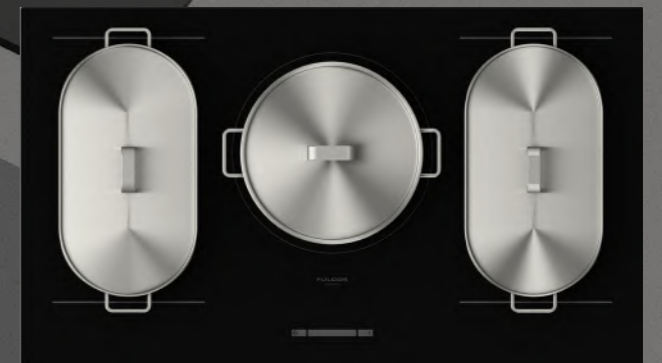
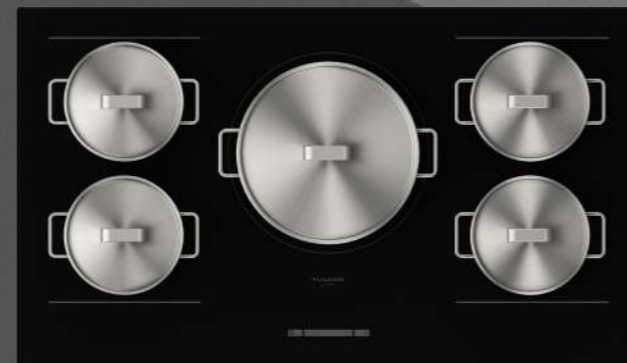
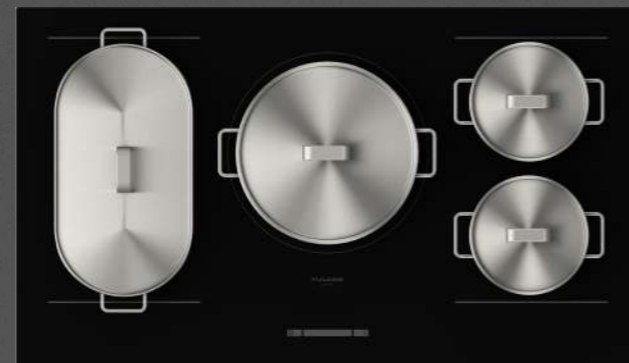



## Induction hob 90

FSH 905 ID WT MBK



- WAVE Touch Slider controls
- Matte Black Glass Ceramic finish
- 5 cooking zones
- Flexi zone (Automatic Bridge)
- Heating BOOSTER
- Automatic pre-heating function
- Pre-Set: 40°, 70°, 90°C
- Timer

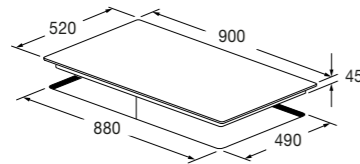

### Features

This hob features two concentric areas of various sizes and power, called DUAL MAX POWER. Therefore, it automatically adapts to pans of various sizes, making the cooking process extremely easy and comfortable. Other functions available: pan detection sensor, touch control lock, residual heat indicator (H) and automatic power-off with temperature sensor.

It also comes with a surface cleaning scraper.

Technical data

page 381



MATTE BLACK GLASS CERAMIC  
FSH 905 ID WT MBK  
EAN 8019801030835



## Induction hob 80

FSH 804 ID WT MBK



- WAVE Touch Slider controls
- Matte Black Glass Ceramic finish
- 4 cooking zones
- Flexi zone (Automatic Bridge)
- Heating BOOSTER
- Automatic pre-heating function
- Pre-Set: 40°, 70°, 90°C
- Timer

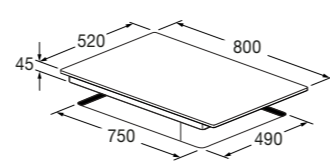

### Features

This hob features two concentric areas of various sizes and power, called DUAL MAX POWER. Therefore, it automatically adapts to pans of various sizes, making the cooking process extremely easy and comfortable. Other functions available: pan detection sensor, touch control lock, residual heat indicator (H) and automatic power-off with temperature sensor.

It also comes with a surface cleaning scraper.

Technical data

page 381



MATTE BLACK GLASS CERAMIC  
FSH 804 ID WT MBK  
EAN 8019801030811

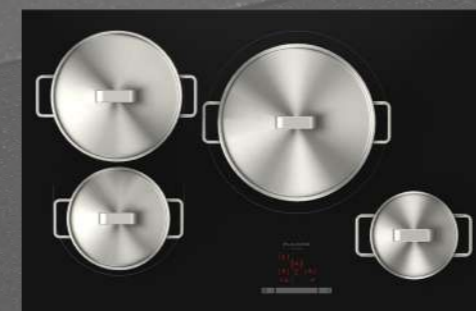
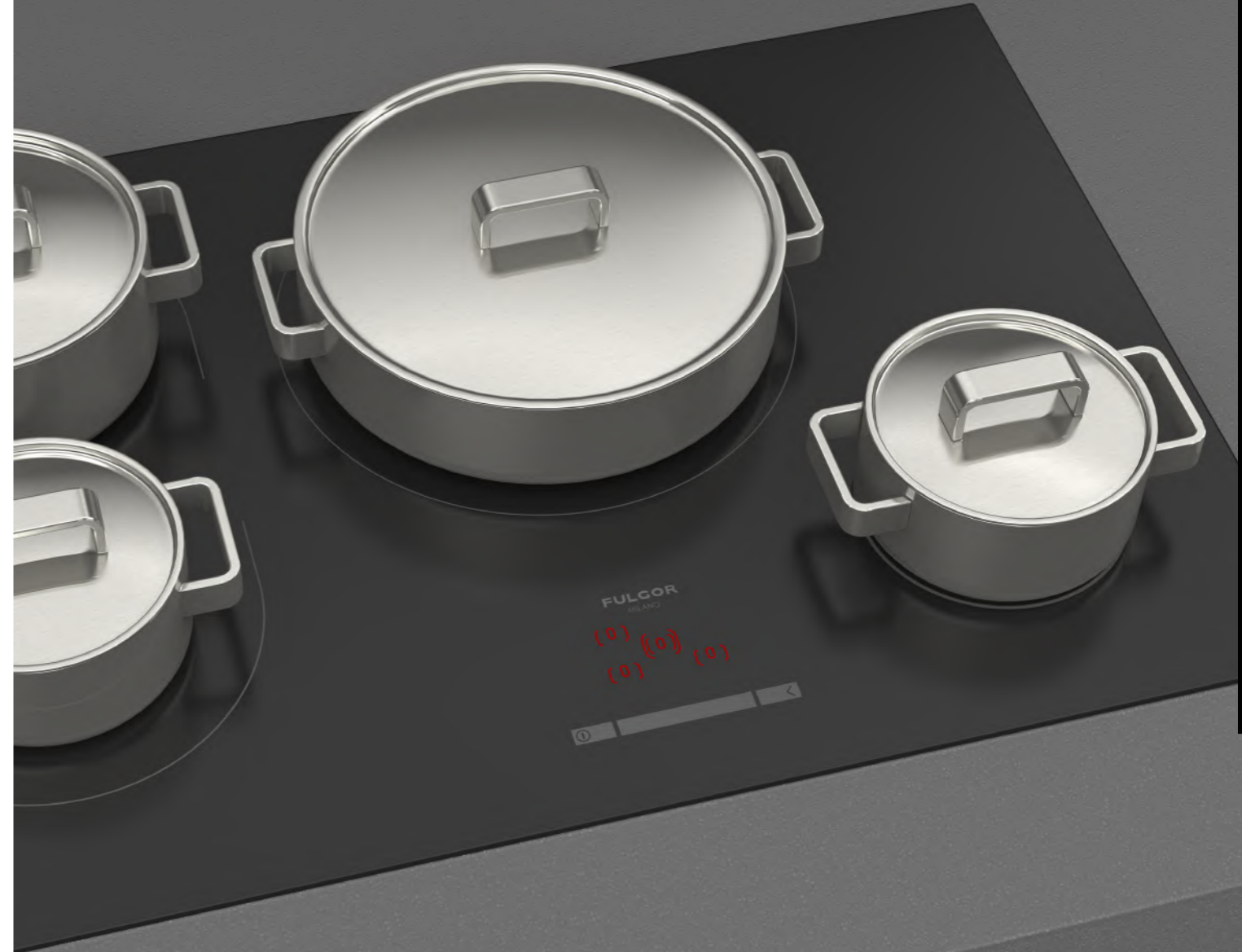



### Hybrid hob 90

FCHH 905 ID TS G DWK BK



- Touch Slider controls
- Black Glass Ceramic finish
- Wok DUAL adjustment
- Cast iron grate
- 4 Cooking zones (2 vertical bridge zones)
- Pause function
- Automatic pre-heating function
- Pre-Set: 40°C
- Timer

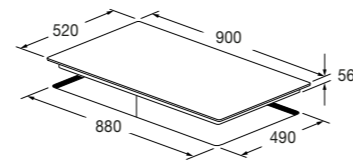

### Features

The hybrid hob combines the advantages of an induction hob with those of a brass gas wok burner (4.0 kW). This induction hob features four cooking zones with 9 power levels. The hob is fitted with slider touch controls and a timer (automatic power-off). Moreover, it digitally displays the selected power for each cooking zone and allows you to select the heat maintenance mode. The safety system includes an automatic pan detection system, a safety switch, a residual heat light indicator (H), and Stop-Gas function for the wok burner.

The hob comes with the following accessories a surface cleaning scraper, a cast iron wok adapter, and a small pan reduction.

Technical data

page 378



BLACK GLASS CERAMIC  
FCHH 905 ID TS G DWK BK  
EAN 8019801031603



WHITE GLASS CERAMIC  
FCHH 905 ID TS G DWK WH  
EAN 8019801031610

**FULGOR**  
MILANO

## HYBRID HOB

Unleash your creativity in the kitchen thanks to the multiple possibilities ensured by FULGOR MILANO's hybrid hob. The hybrid hob combines the advantages of an induction hob with those of a brass gas wok burner (4.0 kW) for delicious stir-fry recipes. The induction area features four cooking zones with nine power levels. The hob is fitted with slider touch controls and a timer (automatic power-off). Moreover, it digitally displays the selected power for each cooking zone and allows you to select the heat maintenance mode. The induction system detects pans automatically. In addition, it features a residual heat light indicator (H) and a safety switch to prevent burns resulting from accidental use. The wok burner has a power on/off gas detection system in case of accidental gas leaks during use. The hob comes with the following accessories: a surface cleaning scraper, a cast iron wok adapter, and a small pan reduction.

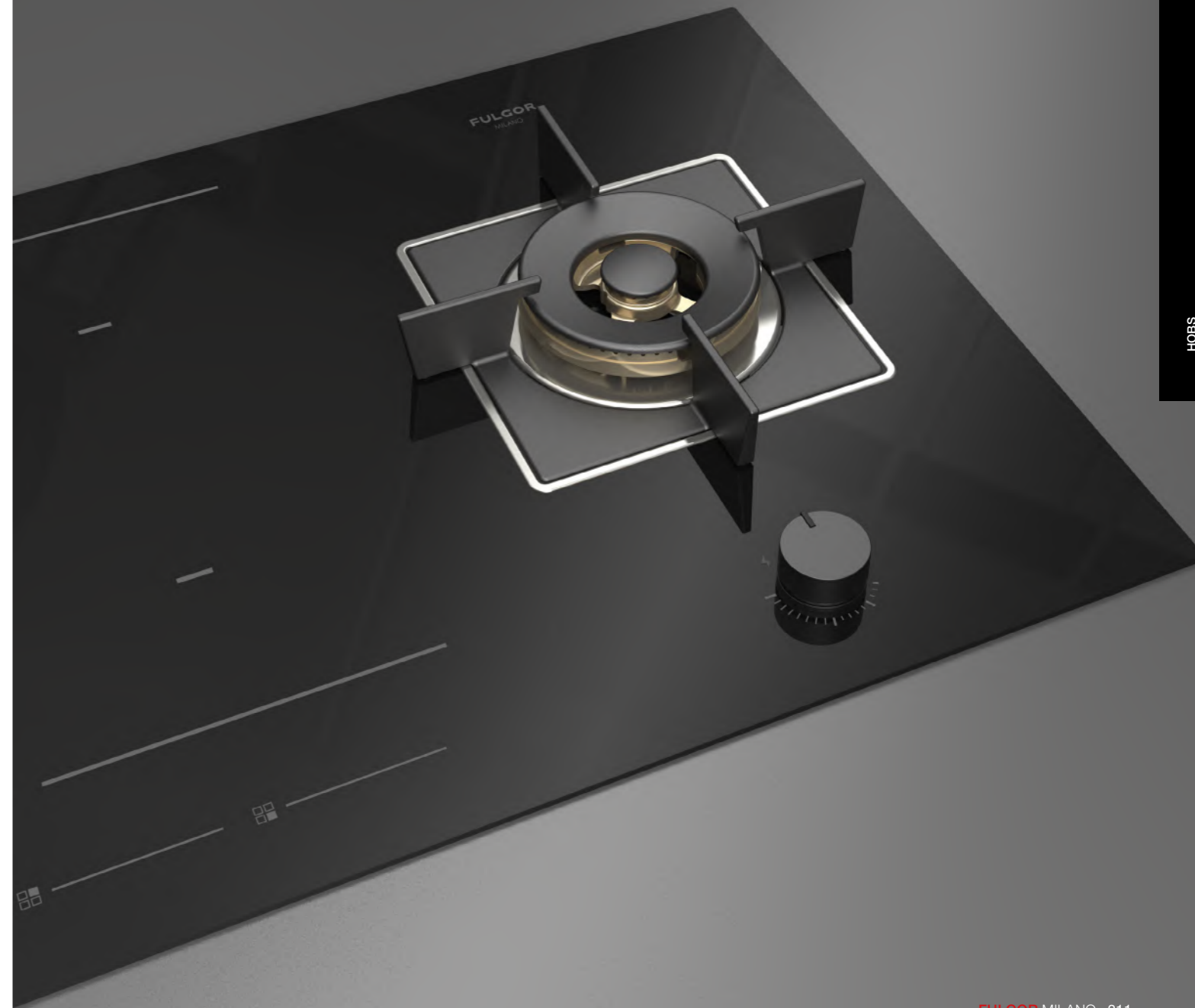

**FULGOR**  
MILANO

# GAS HOBS



THE UNIQUE FIRE WARMTH

FULGOR  
MILANO

GAS HOBS

# HALO VISION



The elegant glass-ceramic surface combines with the gas power. Professional cast iron grates are lighted by efficient burners with brass rings. These glass-ceramic hobs are fitted with a timer (auto power-off) and the exclusive Halo Vision function. The adjustable knobs' backlight indicates the gas burner is on (white light) or residual heat (red light).



**GAS HOBS**  
**HALO VISION**



**HALO VISION**

Halo Vision is an innovative technology that uses a white light (Halo Control) to indicate when the hob is still lit and a red light (Halo Safe) to indicate the presence of residual heat (Halo Safe). This way, you can leave the kitchen with peace of mind.

**CAST IRON GRATES**

The elegant and robust professional cast iron grates allow you to move the pans easily, thanks to their aligned surfaces.

**TIMER**

To make your cooking more efficient, you can set the cooking timer and turn off the burners with extreme precision.



**Gas hob 90**

FCLH 905 G T WK BK



- Electronic ignition
- Black Glass Ceramic finish
- Halo Vision knobs
- Brass burners
- Professional cast iron grates

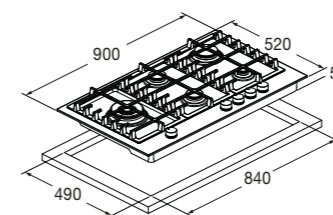

**Features**

The hob is provided with Halo Vision, an innovative technology that warns you whether the burner is left ignited (white light under the knob) or if there's residual heat (red light). To make your cooking more efficient, you can regulate cooking time and set when to turn off the burners with extreme precision, thanks to the timer. The hob has 5 gas burners, including a brass Wok (4.0 kW), keypad safety, auto power-off timer, end-of-cooking beep, and Stop-Gas detection system. It includes a surface cleaning scraper and a Wok reducer.

Technical data

page 382



BLACK GLASS CERAMIC  
FCLH 905 G T WK BK  
EAN 8019801024896



**Gas hob 75**

FCLH 755 G T WK BK



- Electronic ignition
- Black Glass Ceramic finish
- Halo Vision knobs
- Brass burners
- Professional cast iron grates

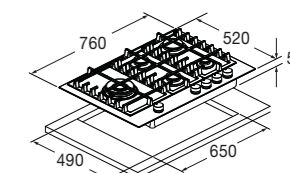

**Features**

The hob is provided with Halo Vision, an innovative technology that warns you whether the burner is left ignited (white light under the knob) or if there's residual heat (red light). To make your cooking more efficient, you can regulate cooking time and set when to turn off the burners with extreme precision, thanks to the timer. The hob has 5 gas burners, including a brass Wok (4.0 kW), keypad safety, auto power-off timer, end-of-cooking beep, and Stop-Gas detection system. It includes a surface cleaning scraper and a Wok reducer.

Technical data

page 382



BLACK GLASS CERAMIC  
FCLH 755 G T WK BK  
EAN 8019801024889

**FULGOR**  
MILANO

# MATTE BLACK

## GAS HOBS

A set of technical features from the professional world define these products, making them exclusive and appreciated. The hobs have brass burners with a special matte finish (shot peening). This feature provides extreme wear resistance to high flames and colour toning. The metal surface is made with a special matte black enamelled treatment to make it easier to clean and more resistant to heat, preserving it over time.

The knobs' modern design includes an anti-overflow ring, whereas the provided cast iron grates ensure maximum safety and comfort when moving the pans from one burner to another. Moreover, safety is ensured by a thermocouple system that stops accidental gas leaks. The hobs of this range are available in various sizes and layouts to meet any cooking experience.



HOBS

HOBS



Gas hob 90

FUH 9041 G DWK MBK



- Electric ignition under the knob
- Matte Black Metal finish
- Matte black brass burners
- Professional cast iron grates
- Metal knobs Matte Black finish

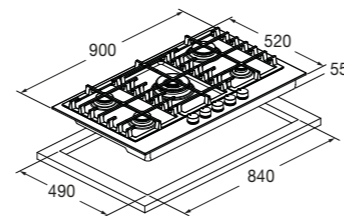

Features

This matte black enamelled product with a unique and exclusive design features metal knobs with a ring nut and 5 brass burners with a matte finish. Wok(4.0 kW) with DUAL regulation. The provided cast iron continuous grates ensure maximum safety and comfort when moving the pans from one burner to another. Moreover, safety is ensured by a thermocouple system that stops accidental gas leaks. It comes with a cast iron wok adapter.

Technical data

page 384



MATTE BLACK METAL  
FUH 9041 G DWK MBK  
EAN 8019801030392



Gas hob 90

FUH 905 G DWK MBK



- Electric ignition under the knob
- Matte Black Metal finish
- Matte black brass burners
- Professional cast iron grates
- Metal knobs Matte Black finish

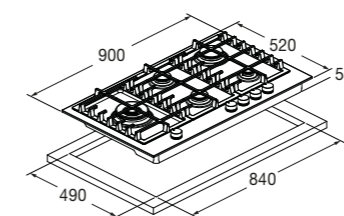

Features

This matte black enamelled product with a unique and exclusive design features metal knobs with a ring nut and 5 brass burners with a matte finish. Wok(4.0 kW) with DUAL regulation. The provided cast iron continuous grates ensure maximum safety and comfort when moving the pans from one burner to another. Moreover, safety is ensured by a thermocouple system that stops accidental gas leaks. It comes with a cast iron wok adapter.

Technical data

page 384



MATTE BLACK METAL  
FUH 905 G DWK MBK  
EAN 8019801027545



Gas hob 75

FUH 7541 G DWK MBK



- Electric ignition under the knob
- Matte Black Metal finish
- Matte black brass burners
- Professional cast iron grates
- Metal knobs Matte Black finish

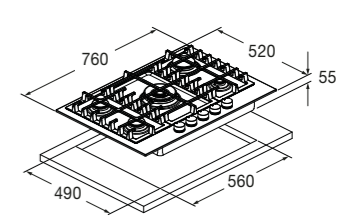

Features

This matte black enamelled product with a unique and exclusive design features metal knobs with a ring nut and 5 brass burners with a matte finish. Wok(4.0 kW) with DUAL regulation. The provided cast iron continuous grates ensure maximum safety and comfort when moving the pans from one burner to another. Moreover, safety is ensured by a thermocouple system that stops accidental gas leaks. It comes with a cast iron wok adapter.

Technical data

page 383



MATTE BLACK METAL  
FUH 7541 G DWK MBK  
EAN 8019801030385



## Gas hob 75

FUH 755 G DWK MBK



- Electric ignition under the knob
- Matte Black Metal finish
- Matte black brass burners
- Professional cast iron grates
- Metal knobs Matte Black finish

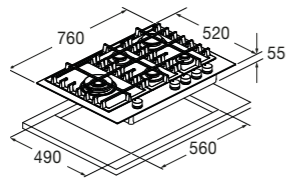

## Features

This matte black enamelled product with a unique and exclusive design features metal knobs with a ring nut and 5 brass burners with a matte finish. Wok(4.0 kW) with DUAL regulation. The provided cast iron continuous grates ensure maximum safety and comfort when moving the pans from one burner to another. Moreover, safety is ensured by a thermocouple system that stops accidental gas leaks. It comes with a cast iron wok adapter.

Technical data

page 383



MATTE BLACK METAL  
FUH 755 G DWK MBK  
EAN 8019801027538

## Gas hob 60

FUH 604 G DWK MBK



- Electric ignition under the knob
- Matte Black Metal finish
- Matte black brass burners
- Professional cast iron grates
- Metal knobs Matte Black finish

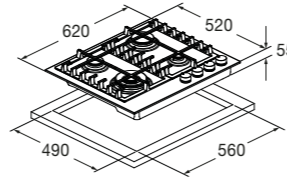

## Features

This matte black enamelled product with a unique and exclusive design features metal knobs with a ring nut and 5 brass burners with a matte finish. Wok(4.0 kW) with DUAL regulation. The provided cast iron continuous grates ensure maximum safety and comfort when moving the pans from one burner to another. Moreover, safety is ensured by a thermocouple system that stops accidental gas leaks. It comes with a cast iron wok adapter.

Technical data

page 383



MATTE BLACK METAL  
FUH 604 G DWK MBK  
EAN 8019801029587

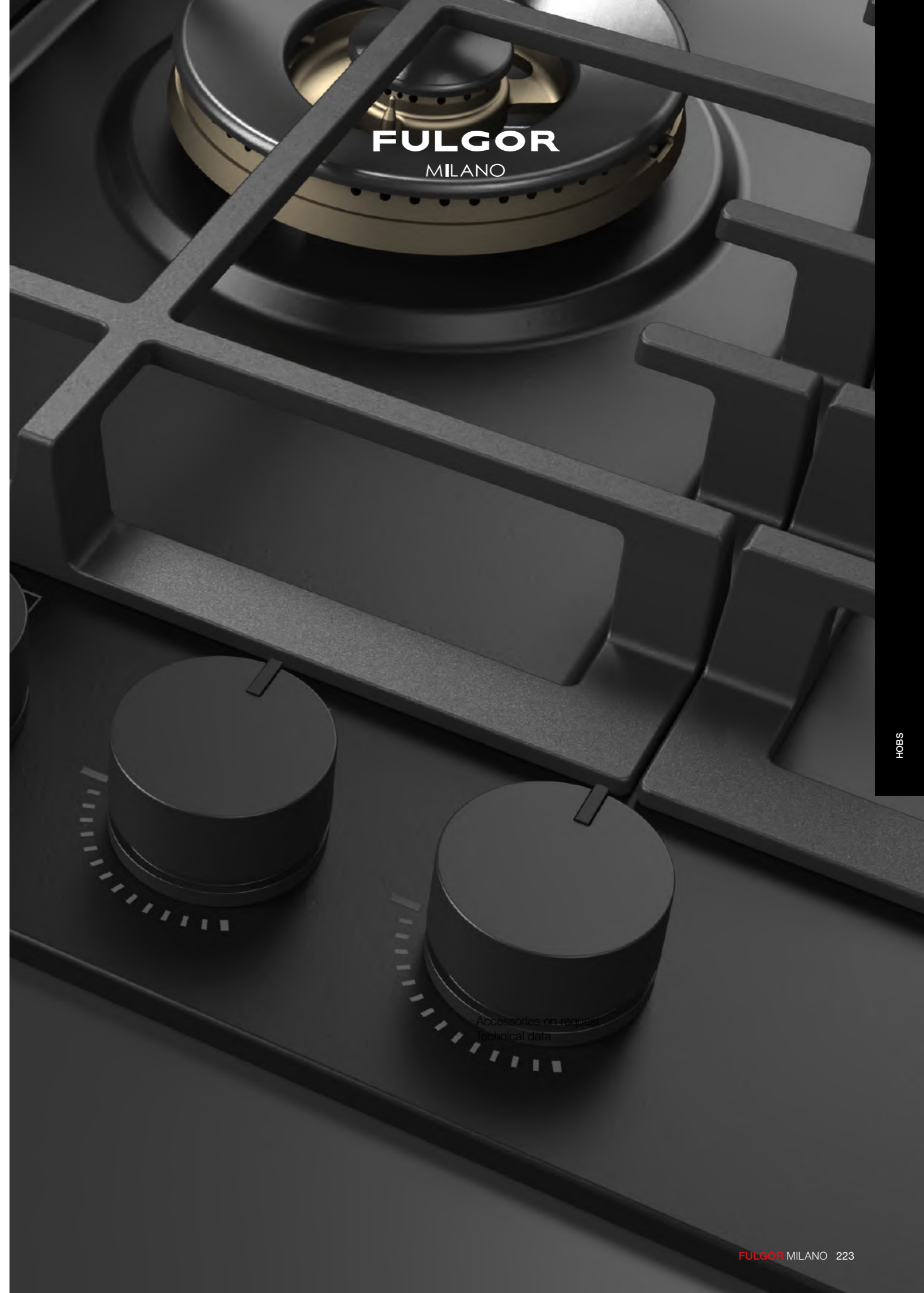

Accessories on request  
Technical data

**FULGOR**  
MILANO

# STAINLESS STEEL GAS HOBS

Various technical features from the professional world define these products, making them unique and exclusive. The knobs' modern design includes an anti-overflow ring, whereas the provided cast iron continuous grates ensure maximum safety and comfort when moving the pans from one burner to another. Moreover, safety is ensured by a thermocouple system that stops accidental gas leaks. The hobs of this range are available in various sizes and layouts to meet any cooking experience.



HOBS

HOBS



**Gas hob 90**

**FPH 906 G WK X**



- Electric ignition under the knob
- Fine satin-finish stainless steel finish
- Low Edge profile
- Burners with brass flame spreader
- Brass wok burner
- Professional cast iron grates
- Metal knobs with a stainless steel finish

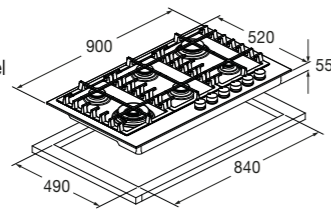

**Features**

This product, with a unique and exclusive design, features a stainless steel finish, metal knobs with a ring nut, and 6 brass burners with a flame spreader. Wok (4.0 kW). The provided cast iron continuous grates ensure maximum safety and comfort when moving the pans from one burner to another. Moreover, safety is ensured by a thermocouple system that stops accidental gas leaks. It comes with a cast iron wok adapter.

Technical data page 385



STAINLESS STEEL  
FPH 906 G WK X  
EAN 8019801032419



**Gas hob 90**

**FPH 9041 G WK X**



- Electric ignition under the knob
- Fine satin-finish stainless steel finish
- Low Edge profile
- Burners with brass flame spreader
- Brass wok burner
- Professional cast iron grates
- Metal knobs with a stainless steel finish

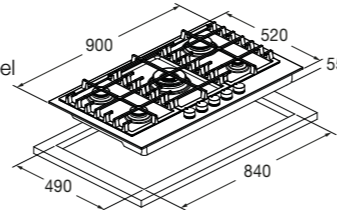

**Features**

This hob features metal knobs with a ring nut and 5 brass burners with a flame spreader. Wok (4.0 kW) in the centre. The provided cast iron continuous grates ensure maximum safety and comfort when moving the pans from one burner to another. Moreover, safety is ensured by a thermocouple system that stops accidental gas leaks. It comes with a cast iron wok adapter.

Technical data page 385



STAINLESS STEEL  
FPH 9041 G WK X  
EAN 8019801032426



**Gas hob 90**

**FPH 905 G WK X**



- Electric ignition under the knob
- Fine satin-finish stainless steel finish
- Low Edge profile
- Burners with brass flame spreader
- Brass wok burner
- Professional cast iron grates
- Metal knobs with a stainless steel finish

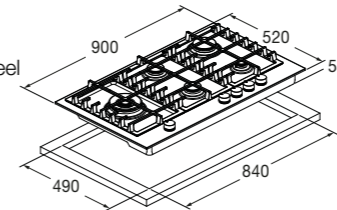

**Features**

This product with a unique and exclusive design features a stainless steel finish, metal knobs with a ring nut, and 5 brass burners with a flame spreader. Wok (4.0 kW) on the left-hand side. The provided cast iron continuous grates ensure maximum safety and comfort when moving the pans from one burner to another. Moreover, safety is ensured by a thermocouple system that stops accidental gas leaks. It comes with a cast iron wok adapter.

Technical data page 385



STAINLESS STEEL  
FPH 905 G WK X  
EAN 8019801032433



**Gas Hob 75**

**FPH 7541 G WK X**



- Electric ignition under the knob
- Fine satin-finish stainless steel finish
- Low Edge profile
- Burners with brass flame spreader
- Brass wok burner
- Professional cast iron grates
- Metal knobs with a stainless steel finish

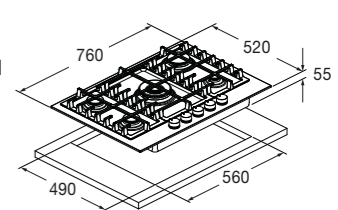

**Features**

The 75 cm hob features metal knobs with a ring nut and 5 brass burners with a flame spreader. Wok (4.0 kW) in the centre. The provided cast iron continuous grates ensure maximum safety and comfort when moving the pans from one burner to another. Moreover, safety is ensured by a thermocouple system that stops accidental gas leaks. It comes with a cast iron wok adapter.

Technical data page 386



STAINLESS STEEL  
FPH 7541 G WK X  
EAN 8019801032440



**Gas hob 75**

FPH 755 G WK X



- Electric ignition under the knob
- Fine satin-finish stainless steel finish
- Low Edge profile
- Burners with brass flame spreader
- Brass wok burner
- Professional cast iron grates
- Metal knobs with a stainless steel finish

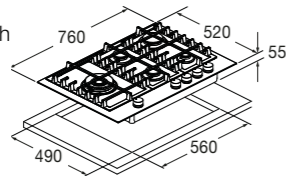

**Features**

This product with a unique and exclusive design features a stainless steel finish, metal knobs with a ring nut, and 5 brass burners with a flame spreader. Wok (4.0 kW) on the left-hand side. The provided cast iron continuous grates ensure maximum safety and comfort when moving the pans from one burner to another. Moreover, safety is ensured by a thermocouple system that stops accidental gas leaks. It comes with a cast iron wok adapter.

Technical data

page 386



STAINLESS STEEL  
FPH 755 G WK X  
EAN 8019801032457



**Gas hob 60**

FPH 604 G WK X



- Electric ignition under the knob
- Fine satin-finish stainless steel finish
- Low Edge profile
- Burners with brass flame spreader
- Brass wok burner
- Professional cast iron grates
- Metal knobs with a stainless steel finish

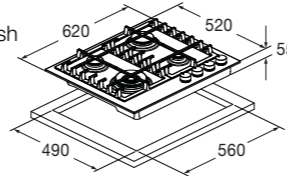

**Features**

The 60 cm hob has a unique and exclusive design and features a stainless steel finish, metal knobs with a ring nut, and 4 brass burners with a flame spreader. Wok (4.0 kW) on the bottom left-hand side. The provided cast iron continuous grates ensure maximum safety and comfort when moving the pans from one burner to another. Moreover, safety is ensured by a thermocouple system that stops accidental gas leaks. It comes with a cast iron wok adapter.

Technical data

page 386



STAINLESS STEEL  
FPH 604 G WK X  
EAN 8019801031795

**FULGOR**  
MILANO



**FULGOR**  
MILANO

# GAS HOBS ON GLASS

These stylish and high-performance hobs stand out also for being easy to clean, thanks to the smooth glass surface (8 mm thick), the continuous grate, and the powerful burners. The cast iron continuous grates are a safe supporting surface for easy handling of the pans.

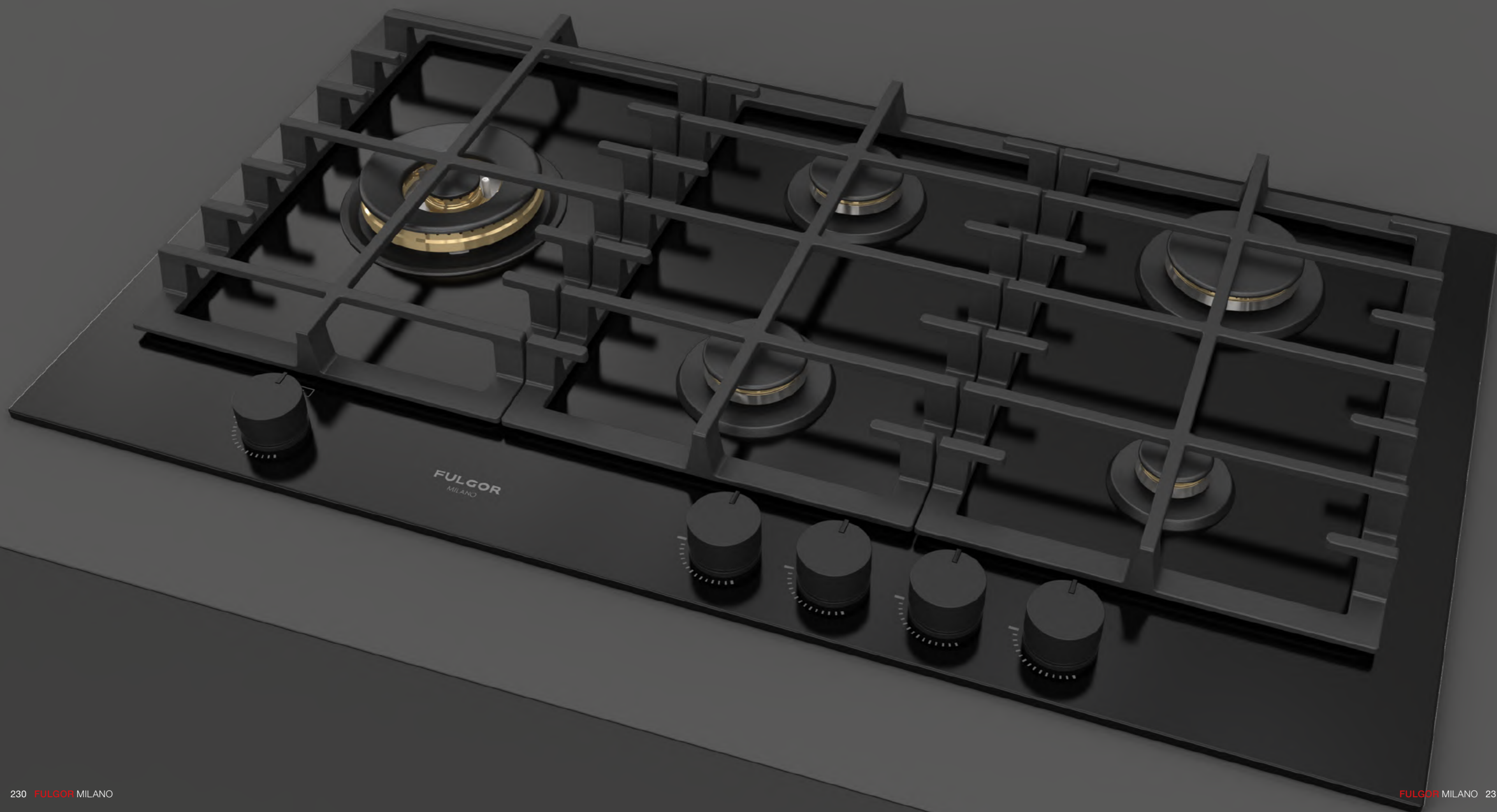

HOBS

## BLACK GAS HOBS ON GLASS



### KNOBS

The best solution for sturdy, long-lasting knobs that facilitate individual hob adjustment due to their frontal position.



### FLAME FAILURE DEVICE

The Flame Failure Device detects accidental flame extinguishment and blocks the gas supply to prevent leaks and improve safety.

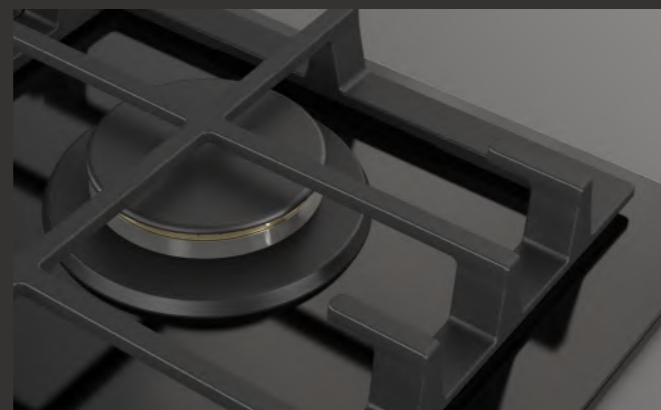

## WHITE GAS HOBS ON GLASS

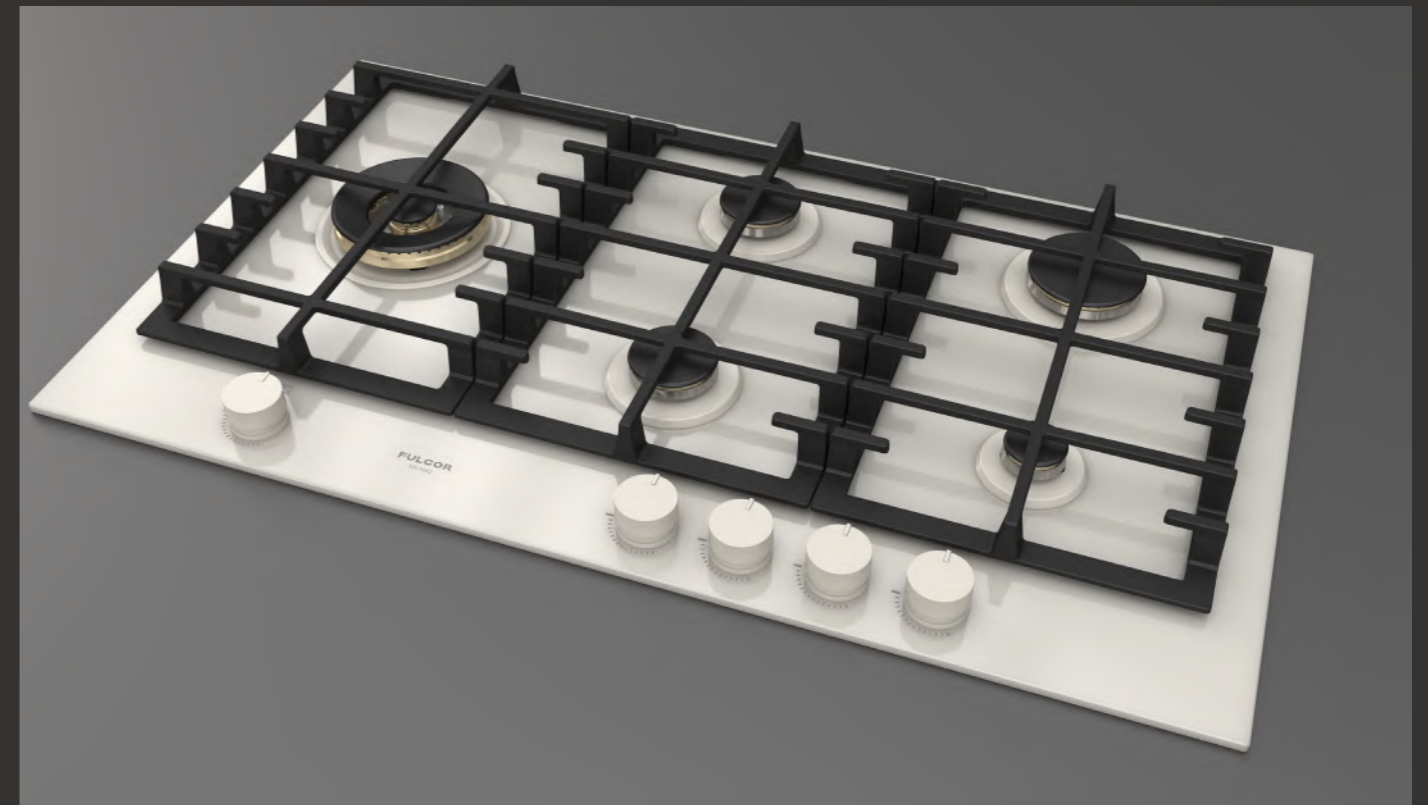

### WOK BURNER

A cast-iron adaptor (power modulation up to 4.0 kW) is provided, allowing original wok pans to be positioned easily.



### ELECTRIC IGNITION UNDER THE KNOB

All you have to do is turn the knob in the indicated direction to switch on the connected burner without holding it down for too long.





**Gas hob 90**

FPH 905 G WK BKG



- Electric ignition under the knob
- Black Glass finish
- Burners with brass flame spreader
- Brass wok burner
- Professional cast iron grates
- Metal knobs with matte black finish

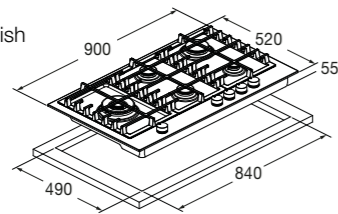

**Features**

The 90 cm hob has a unique and exclusive design and features a black or white glass finish, metal knobs with a ring nut, and 5 brass burners with a flame spreader. Wok (4.0 kW) on the left-hand side. The provided cast iron continuous grates ensure maximum safety and comfort when moving the pans from one burner to another. Moreover, safety is ensured by a thermocouple system that stops accidental gas leaks. It comes with a cast iron wok adapter.

Technical data

page 387



BLACK GLASS  
FPH 905 G WK BKG  
EAN 8019801032464

WHITE GLASS  
FPH 905 G WK WHG  
EAN 8019801032495



**Gas hob 75**

FPH 755 G WK BKG



- Electric ignition under the knob
- Black Glass finish
- Burners with brass flame spreader
- Brass wok burner
- Professional cast iron grates
- Metal knobs with matte black finish

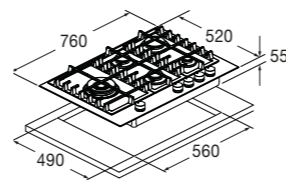

**Features**

The 75 cm hob has a unique and exclusive design and features a black or white glass finish, metal knobs with a ring nut, and 5 brass burners with a flame spreader. Wok (4.0 kW) on the left-hand side. The provided cast iron continuous grates ensure maximum safety and comfort when moving the pans from one burner to another. Moreover, safety is ensured by a thermocouple system that stops accidental gas leaks. It comes with a cast iron wok adapter.

Technical data

page 387



BLACK GLASS  
FPH 755 G WK BKG  
EAN 8019801032471

WHITE GLASS  
FPH 755 G WK WHG  
EAN 8019801032501



**Gas hob 60**

FPH 604 G WK BKG



- Electric ignition under the knob
- Black Glass finish
- Burners with brass flame spreader
- Brass wok burner
- Professional cast iron grates
- Metal knobs with matte black finish

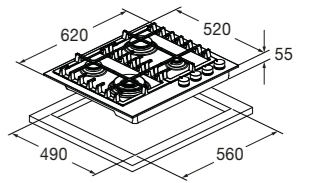

**Features**

The 60 cm hob has a unique and exclusive design and features a black or white glass finish, metal knobs with a ring nut, and 4 brass burners with a flame spreader. Wok (4.0 kW) on the bottom left-hand side. The provided cast iron continuous grates ensure maximum safety and comfort when moving the pans from one burner to another. Moreover, safety is ensured by a thermocouple system that stops accidental gas leaks. It comes with a cast iron wok adapter.

Technical data

page 387



BLACK GLASS  
FPH 604 G WK BKG  
EAN 8019801032488

WHITE GLASS  
FPH 604 G WK WHG  
EAN 8019801032518

**FULGOR**  
MILANO

**GAS HOBS | P DESIGN**

# STAINLESS STEEL TOP-FLUSH-MOUNT

**FULGOR**  
MILANO



## **PROFESSIONAL STEEL KNOBS**

Metal knobs ensure easy handling and intuitive and accurate control when cooking.

## **CAST IRON GRATES**

The cast iron continuous grates are built to resist extreme heat and quick changes in temperature without losing sturdiness. They are also easy to clean, allowing you to handle the pans efficiently.

## **GAS SAFETY**

Gas hobs with a safety valve: the gas flow stops when the flame extinguishes, even accidentally.

## **FLUSH-MOUNT OR SEMI-FLUSH-MOUNT**

P design hobs have a 1 mm edge. They can be flush-mounted or semi-flush-mounted, thanks to their smooth and regular surface.



**Gas hob 112**  
CPH 1124 GWK X



- Electric ignition under the knob
- Stainless steel finish
- Metal knobs with stainless steel finish
- Aluminium burners
- Aluminium wok burner
- Sturdy cast iron grates

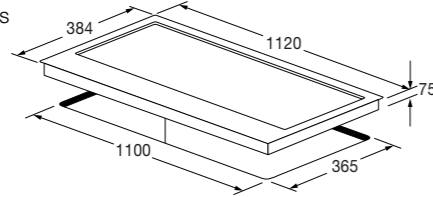

**Features**

The hob features a 1 mm thick edge. This way, it can be flush-mounted or semi-flush-mounted on the kitchen's countertop. It has 4 in-line burners, including a Wok (4.0 kW) and a Stop-Gas detection system. It comes with a cast iron Wok adapter.

Technical data page 388



SATIN-FINISH STAINLESS STEEL  
CPH 1124 GWK X  
EAN 8019801011032



**Gas hob 90**  
CPH 905 GWK X



- Electric ignition under the knob
- Stainless steel finish
- Metal knobs with stainless steel finish
- Aluminium burners
- Aluminium wok burner
- Sturdy cast iron grates

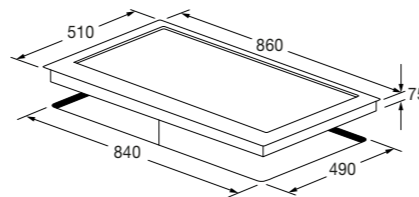

**Features**

The hob features a 1 mm thick edge. This way, it can be flush-mounted or semi-flush-mounted on the kitchen's countertop. It has 5 burners, including a central Wok (4.0 kW) and a Stop-Gas detection system. It comes with a cast iron Wok adapter.

Technical data page 388



SATIN-FINISH STAINLESS STEEL  
CPH 905 GWK X  
EAN 8019801011049



**Gas hob 75**  
CPH 765 GWK X



- Electric ignition under the knob
- Stainless steel finish
- Metal knobs with stainless steel finish
- Aluminium burners
- Aluminium wok burner
- Sturdy cast iron grates

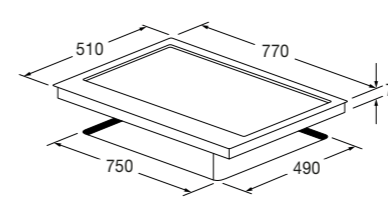

**Features**

The 75 cm hob features a 1 mm thick edge. This way, it can be flush-mounted or semi-flush-mounted on the kitchen's countertop. It has 5 burners, including a central Wok (4.0 kW) and a Stop-Gas detection system. It comes with a cast iron Wok adapter.

Technical data page 388



SATIN-FINISH STAINLESS STEEL  
CPH 765 GWK X  
EAN 8019801011056



**Gas hob 60**  
CPH 604 G X



- Electric ignition under the knob
- Stainless steel finish
- Metal knobs with stainless steel finish
- Aluminium burners
- Sturdy cast iron grates

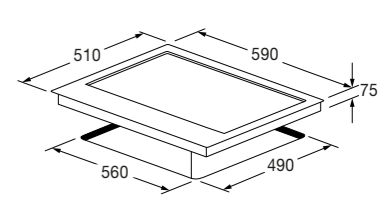

**Features**

The 60 cm hob features a 1 mm thick edge. This way, it can be flush-mounted or semi-flush-mounted on the kitchen's countertop. It has 4 burners and a Stop-Gas detection system. It comes with a cast iron Wok adapter.

Technical data page 388



SATIN-FINISH STAINLESS STEEL  
CPH 604 G X  
EAN 8019801011063

GAS HOBS | S DESIGN

# BRUSHED STAINLESS STEEL

These cooktops are available in two materials and thicknesses: brushed stainless steel (5 mm) and glossy tempered glass (8 mm). Both versions are elegant, sturdy and long-lasting, revealing a strong personality thanks to the rounded finish on the 4 sides.



FULGOR  
MILANO

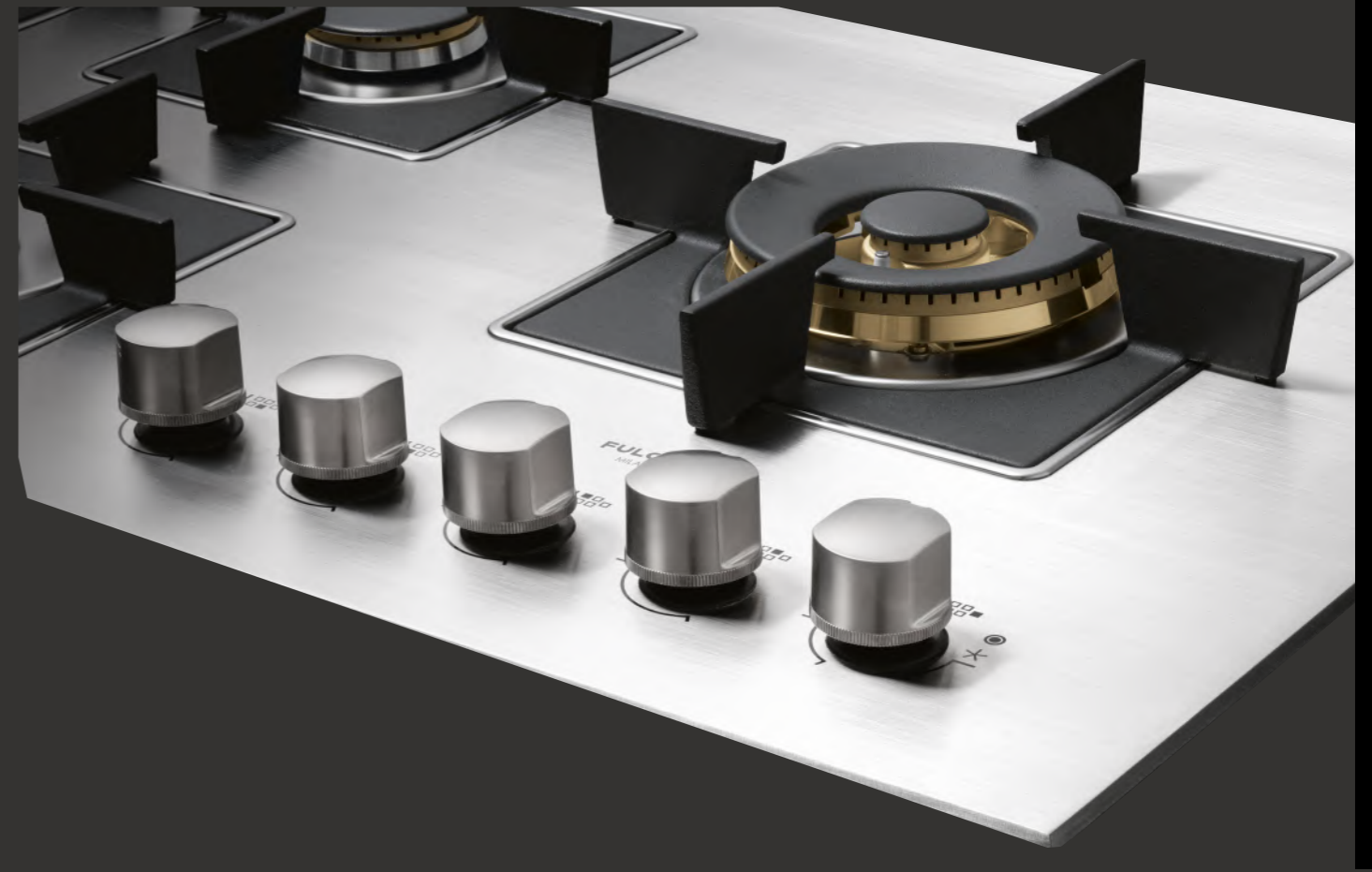

## CONTROL KNOBS

Sturdy brushed metal knobs are easy to handle and ensure accurate control.

## BRASS BURNERS

The high-efficiency brass burners ensure even heat distribution for perfect cooking results. Brass resists high temperatures, making the burners long-lasting.

## WOK WITH DUAL REGULATION

High-power, modular WOK burner. The DUAL control makes it easy to select and combine the various rings. It is provided with a cast iron adapter to position the wok pans.

## CAST IRON GRATES FOR EACH ZONE

The cast iron grates are designed to provide stability to the pans. These sturdy and long-lasting single grates are easy to handle and clean.



**Gas hob 112**

FSH 1124 G 2DWK XX



- Electric ignition under the knob
- Stainless steel finish
- Diamond finish perimeter
- Metal knobs with stainless steel finish
- Burners with brass flame spreader
- Brass wok burner
- Single cast iron grates

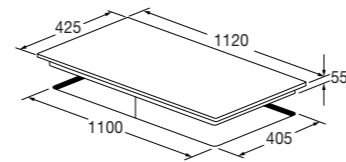

**Features**

This hob features a 5 mm thick stainless steel surface. It has 4 in-line burners, including 2 brass Woks (4.0 kW) with DUAL regulation (at the hob's ends). This hob comes with Stop-Gas safety system. The cast iron grates are designed to provide stability to every cooking zone. It comes with a cast iron Wok adapter and a Cast Iron Small adapter.

Technical data

page 389



BRUSHED STAINLESS STEEL  
FSH 1124 G 2DWK XX  
EAN 8019801017676

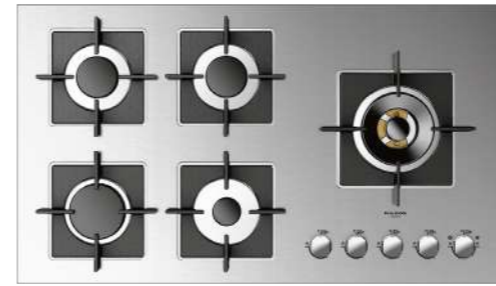

**Gas hob 90**

FSH 905 G DWK XX



- Electric ignition under the knob
- Stainless steel finish
- Diamond finish perimeter
- Metal knobs with stainless steel finish
- Burners with brass flame spreader
- Brass wok burner
- Single cast iron grates

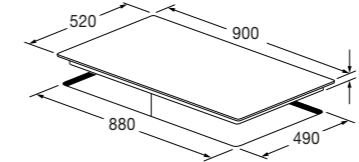

**Features**

The hob features 5 burners, including a brass Wok (4.0 kW) with DUAL regulation (at the hob's right-hand side). This hob features a 5 mm thick stainless steel surface. This hob comes with Stop-Gas safety system. The cast iron grates are designed to provide stability to every cooking zone. It comes with a cast iron Wok adapter and a Cast Iron Small adapter.

Technical data

page 389



BRUSHED STAINLESS STEEL  
FSH 905 G DWK XX  
EAN 8019801017683

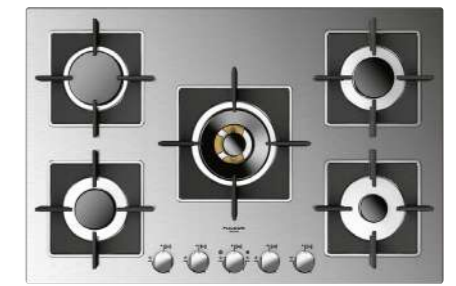

**Gas hob 75**

FSH 775 G DWK XX



- Electric ignition under the knob
- Stainless steel finish
- Diamond finish perimeter
- Metal knobs with stainless steel finish
- Burners with brass flame spreader
- Brass wok burner
- Single cast iron grates

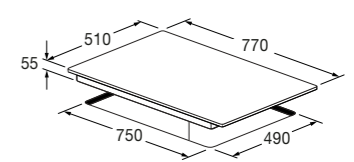

**Features**

This hob features a 5 mm thick stainless steel surface. The hob features 5 burners, including a brass Wok (4.0 kW) with DUAL regulation (at the hob's centre). This hob comes with Stop-Gas safety system. The cast iron grates are designed to provide stability to every cooking zone. It comes with a cast iron Wok adapter and a Cast Iron Small adapter.

Technical data

page 389



BRUSHED STAINLESS STEEL  
FSH 775 G DWK XX  
EAN 8019801017690



GAS HOBS  
POLISHED GLASS



Gas hob 112

FCH 1124 G 2DWK BK



Gas hob 90

FCH 905 G DWK BK



- Electric ignition under the knob
- Black Glass finish
- Bevelled finish perimeter
- Metal knobs with stainless steel finish
- Burners with brass flame spreader
- Brass wok burner
- Single cast iron grates

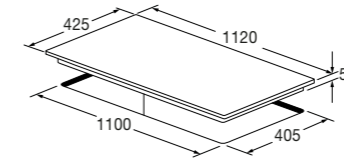

Features

This hob has a bevelled glass surface and 4 in-line burners, including 2 brass Woks (4.0 kW) with DUAL regulation (at the hob's ends). This hob comes with Stop-Gas safety system. The cast iron grates are designed to provide stability to every cooking zone. It comes with a cast iron Wok adapter and a Cast Iron Small adapter.

Technical data

page 390



BLACK GLASS  
FCH 1124 G 2DWK BK  
EAN 8019801017775



- Electric ignition under the knob
- Black Glass finish
- Bevelled finish perimeter
- Metal knobs with stainless steel finish
- Burners with brass flame spreader
- Brass wok burner
- Single cast iron grates

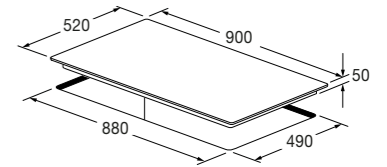

Features

This hob has a bevelled glass surface and features 5 burners, including a brass Wok (4.0 kW) with DUAL regulation (at the hob's right-hand side). This hob comes with Stop-Gas safety system. The cast iron grates are designed to provide stability to every cooking zone. It comes with a cast iron Wok adapter and a Cast Iron Small adapter.

Technical data

page 390



BLACK GLASS  
FCH 905 G DWK BK  
EAN 8019801017799



**Gas hob 75**

FCH 775 G WK BK



**Gas hob 60**

FCH 604 G BK



- Electric ignition under the knob
- Black Glass finish
- Bevelled finish perimeter
- Metal knobs with stainless steel finish
- Burners with brass flame spreader
- Brass wok burner
- Single cast iron grates

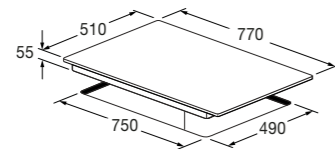

**Features**

This hob has a bevelled glass surface and features 5 burners, including a brass Wok (4.0 kW) with DUAL regulation (at the hob's centre). This hob comes with Stop-Gas safety system. The cast iron grates are designed to provide stability to every cooking zone. It comes with a cast iron Wok adapter and a Cast Iron Small adapter.

Technical data

page 390



BLACK GLASS  
FCH 775 G WK BK  
EAN 8019801017829



- Electric ignition under the knob
- Black Glass finish
- Bevelled finish perimeter
- Metal knobs with stainless steel finish
- Burners with brass flame spreader
- Single cast iron grates

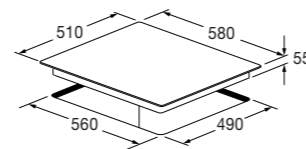

**Features**

This hob has a bevelled glass surface and features 4 burners. This hob comes with Stop-Gas safety system. The cast iron grates are designed to provide stability to every cooking zone. It comes with a cast iron Wok adapter and a Cast Iron Small adapter.

Technical data

page 390



BLACK GLASS  
FCH 604 G BK  
EAN 8019801017850



**GAS HOBS | Q DESIGN**  
**STAINLESS STEEL**

The Q-DESIGN range has a unique burner layout that allows you to use all cooking zones with pans of various sizes simultaneously. The asymmetric position of the WOK burner makes room for larger pans, while the other burners can be used efficiently without interference.

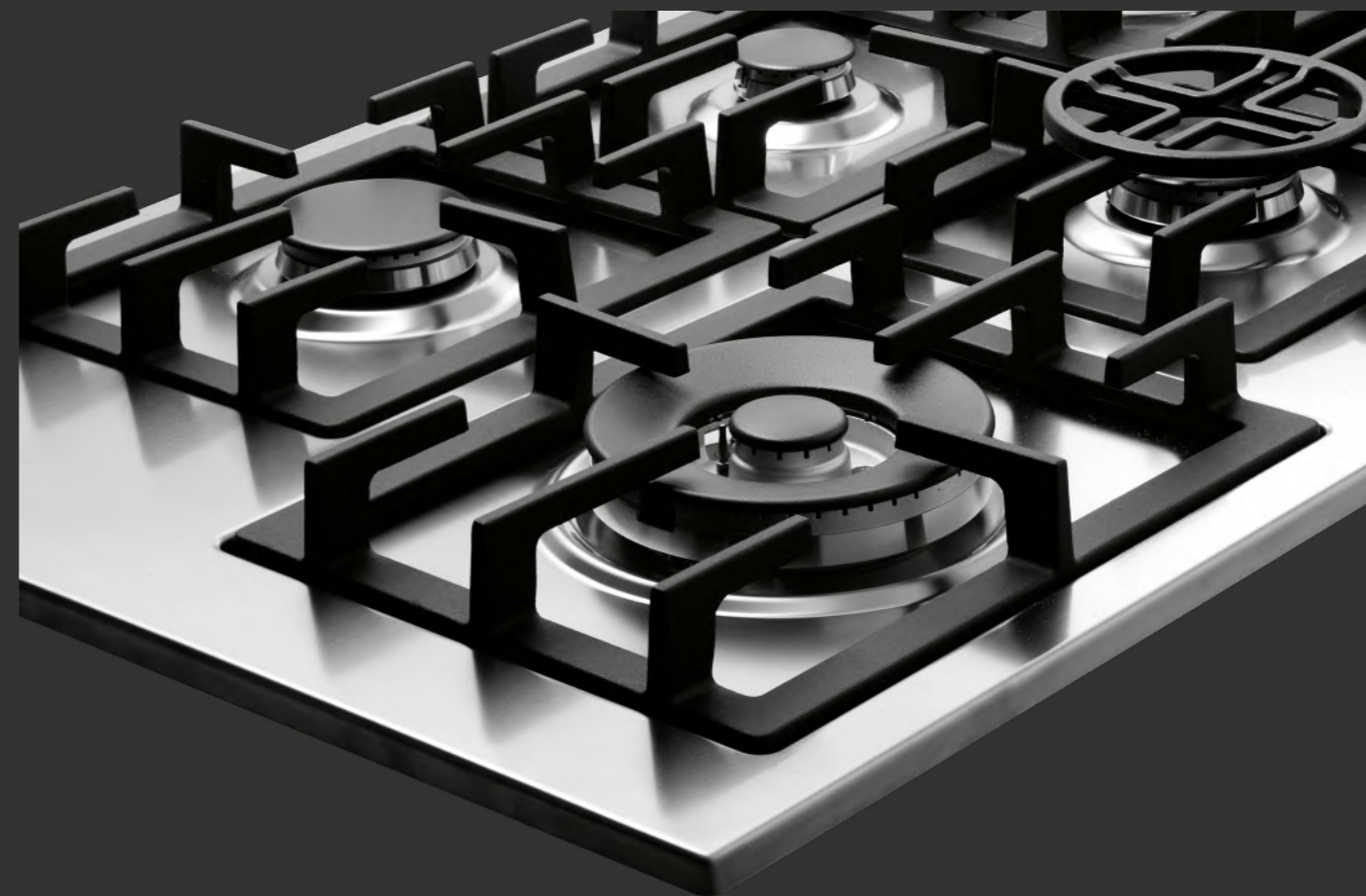
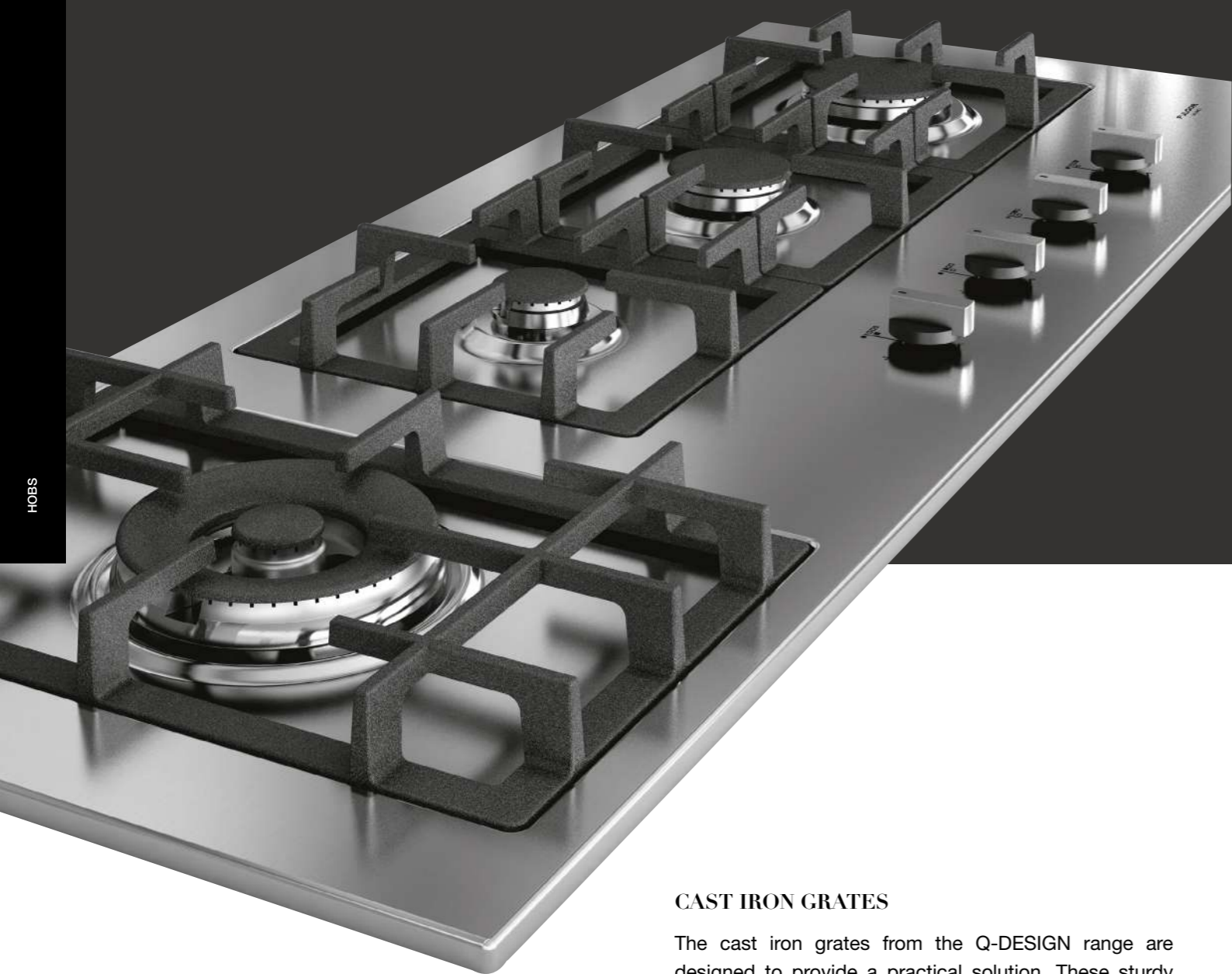

**CAST IRON GRATES**

The cast iron grates from the Q-DESIGN range are designed to provide a practical solution. These sturdy and long-lasting single grates are easy to handle and remove for cleaning purposes.

**METAL KNOBS**

The best solution for sturdy, long-lasting knobs that facilitate individual hob adjustment due to their frontal position.

**FLAME FAILURE DEVICE**

The Flame Failure Device detects accidental flame extinguishment and blocks the gas supply to prevent leaks and improve safety.

**WOK BURNER**

A cast-iron adaptor (power modulation up to 4.0 kW) is provided, allowing original wok pans to be positioned easily.

**ELECTRIC IGNITION UNDER THE KNOB**

All you have to do is turn the knob to the indicated direction and hold it down for max 3 seconds to ignite the desired gas burner.



**Gas hob 112**

QH 1124 GWK X



- Electric ignition under the knob
- Stainless steel finish
- In-line burners
- Knobs with a black stainless steel finish
- Sturdy cast iron grates

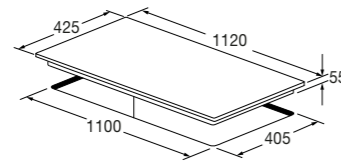

**Features**

This hob features a Wok burner (4.0 kW) on the LH side, away from the other burners, to leave room for the other pans. It also has 4 in-line burners with Stop-Gas system. This hob comes with the following accessories: a cast iron Wok adapter and a cast iron grate reducer.

Technical data page 391



SATIN-FINISH STAINLESS STEEL  
QH 1124 GWK X  
EAN 8019801008889



**Gas hob 90**

QH 906 GWK X



- Electric ignition under the knob
- Stainless steel finish
- Knobs with a black stainless steel finish
- Sturdy cast iron grates

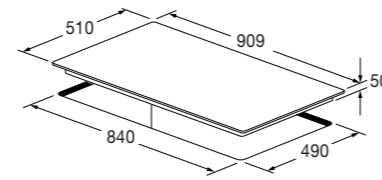

**Features**

This hob features a Wok burner (4.0 kW) on the LH side, away from the other burners, to leave room for the other pans. It also has 6 in-line burners with Stop-Gas system. This hob comes with the following accessories: a cast iron Wok adapter and a cast iron grate reducer.

Technical data page 391



SATIN-FINISH STAINLESS STEEL  
QH 906 GWK X  
EAN 8019801008896



**Gas hob 75**

QH 765 GWK X



- Electric ignition under the knob
- Stainless steel finish
- Knobs with a black stainless steel finish
- Sturdy cast iron grates

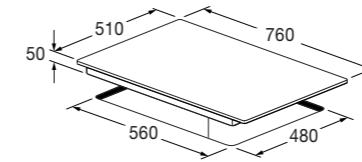

**Features**

This hob features a Wok burner (4.0 kW) on the LH side, away from the other burners, to leave room for the other pans. It also has 5 burners with Stop-Gas system. This hob comes with the following accessories: a cast iron Wok adapter and a cast iron grate reducer.

Technical data page 391



SATIN-FINISH STAINLESS STEEL  
QH 765 GWK X  
EAN 8019801008902



**Gas hob 60**

QH 604 GWK X



- Electric ignition under the knob
- Stainless steel finish
- Knobs with a black stainless steel finish
- Sturdy cast iron grates

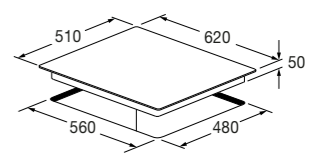

**Features**

It also has 4 burners with Stop-Gas system. This hob features a Wok burner (4.0 kW) on the LH side, away from the other burners, to leave room for the other pans. This hob comes with the following accessories: a cast iron Wok adapter and a cast iron grate reducer.

Technical data page 391



SATIN-FINISH STAINLESS STEEL  
QH 604 GWK X  
EAN 8019801008919

FULGOR  
MILANO

# COMBISET

THE FUNCTIONAL AND MODULAR RANGE



## INDUCTION TEPPANYAKI PLATE

The induction Teppanyaki plate ensures beauty and top performance. Heat is distributed evenly between the two areas of the plate, cooking food naturally without seasonings. The surface can be easily cleaned. The plate remains unchanged over time, resisting discolouration even if it undergoes high temperatures and intensive use.

## INDUCTION HOBS

Glass-ceramic induction hobs feature one or two cooking zones and a stainless steel perimeter. The stainless steel knobs make it easy to choose the cooking settings.

## GAS WOK (1 COOKING ZONE)

The WOK version with DUAL power regulation is perfect for cooking over low and high heat (maximum power = 4 kW). The hob comes with cast iron stands for WOK pans.

## ERGONOMIC CONTROLS

Gas hobs with one or two cooking zones are controlled with steel knobs, whereas some induction models feature touch controls.

## CAST IRON GRATES

Gas hobs are equipped with cast iron grates to ensure maximum pan stability. They can be easily removed and washed.

## FLUSH-MOUNT OR SEMI-FLUSH-MOUNT

Steel gas hobs have a 1 mm edge to be flush-mounted or semi-flush-mounted on the countertop.

## INTEGRATED DOWNDRAFT HOOD

FULGOR MILANO provides extraction systems to be installed next to the cooktop. These efficient and silent systems eliminate odours and smoke.



### Gas hob 40

CPH 401 G DWK X



- Metal knobs with stainless steel finish
- Stainless steel finish
- Brass wok burner (4.0 kW)
- Flexible regulation (DUAL)
- Sturdy cast iron grates

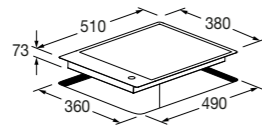

### Features

The hob features a 1 mm thick edge. This way, it can be flush-mounted or semi-flush-mounted on the kitchen's countertop. The burner's DUAL regulation is perfect for cooking over low and high heat (maximum power = 4 kW). The hob is fitted with a Stop-Gas safety system and resistant cast iron grates that can be easily removed. It comes with a cast iron Wok adapter.

Technical data

page 392



STAINLESS STEEL  
CPH 401 G DWK X  
EAN 8019801011070



### Gas hob 40

CPH 402 G X



- Metal knobs with stainless steel finish
- Stainless steel finish
- 2 aluminium burners
- Sturdy cast iron grates

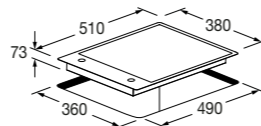

### Features

The product features a 1 mm thick edge. This way, it can be flush-mounted or semi-flush-mounted on the kitchen's countertop. The two cooking zones allow you to use pans of various sizes. The hob is fitted with a Stop-Gas safety system and resistant cast iron grates that can be easily removed.

Technical data

page 392



STAINLESS STEEL  
CPH 402 G X  
EAN 8019801011087



### Induction hob 40

CPH 401 ID X



- Metal knob with stainless steel finish
- Stainless steel finish
- 1 large cooking zone
- Automatic heating
- Digital power level indicator
- Booster

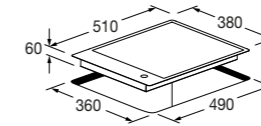

### Features

The product features a 1 mm thick edge. This way, it can be flush-mounted or semi-flush-mounted on the kitchen's countertop. The stainless steel knobs make it easy to choose the cooking settings. The hob features a safety system that includes an end-of-cooking beep and residual heat indicator (H). It also comes with a surface cleaning scraper.

Technical data

page 392



STAINLESS STEEL  
CPH 401 ID X  
EAN 8019801014453



### Induction hob 40

CPH 402 ID X



- Metal knobs with stainless steel finish
- Stainless steel finish
- 2 independent cooking zones
- Automatic heating
- Digital power level indicator
- Booster

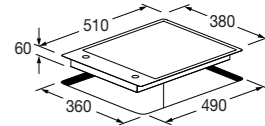

### Features

This hob features a 1 mm thick edge. This way, it can be flush-mounted or semi-flush-mounted on the kitchen's countertop. The stainless steel knobs make it easy to choose the cooking settings. The hob features 2 independent cooking zones and a safety system that includes an end-of-cooking beep and residual heat indicator (H). It also comes with a surface cleaning scraper.

Technical data

page 392



STAINLESS STEEL  
CPH 402 ID X  
EAN 8019801014460



### Induction hob 40

CPH 402 ID TC X/2



- Touch control and digital display
- Stainless steel finish
- 2 independent cooking zones
- Digital power level indicator
- Timer for each zone
- Booster

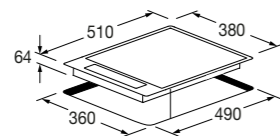

### Features

The hob features a 1 mm thick edge. This way, it can be flush-mounted or semi-flush-mounted on the kitchen's countertop. The touch control and digital display make it easy to choose the cooking settings. The hob features 2 independent cooking zones and a safety system that includes an end-of-cooking beep, touch control lock, and residual heat indicator (H). It also comes with a surface cleaning scraper.

Technical data

page 393



STAINLESS STEEL  
CPH 402 ID TC X/2  
EAN 8019801008858



### Induction hob with Teppanyaki plate 40

CPH 402 ID TY TC X/2



- Touch control
- Stainless steel finish
- 2 independent cooking zones
- Digital power level indicator
- Timer for each zone
- Stainless steel plate (10 mm)
- Groove for collecting cooking residues

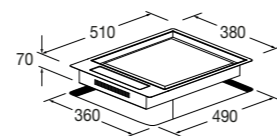

### Features

This hob features a 1 mm thick edge. This way, it can be flush-mounted or semi-flush-mounted on the kitchen's countertop. With the induction Teppanyaki plate, heat is distributed evenly between the two areas of the plate, cooking food naturally without seasonings. The hob includes an end-of-cooking beep, a touch control lock and a residual heat indicator (H).

Technical data

page 393



STAINLESS STEEL  
CPH 402 ID TY TC X/2  
EAN 8019801009688



### Electric barbecue 40

CPH 401 BQ X



- Knob controls
- Stainless steel finish
- Bbq cooking with lava rock in the container
- 11 power levels
- Removable s. steel container
- Grilling with water in the container

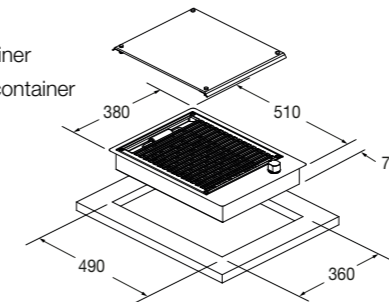

### Features

This small BBQ features a 1 mm thick edge. This way, it can be flush-mounted or semi-flush-mounted on the kitchen's countertop. This product takes little space and uses lava rock or the grill with water in the container to reduce food odours. The hob is fitted with an operation indicator light. It also comes with a black tempered glass cover.

Technical data

page 393



STAINLESS STEEL  
CPH 401 BQ X  
EAN 8019801032525

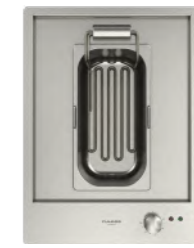

### Electric fryer 40

CPH 401 FR X



- Knob controls
- Stainless steel finish
- Temperature regulation between 40 °C and 200 °C
- Removable s. steel container and basket
- Container capacity 2.7 l
- Oil-based frying

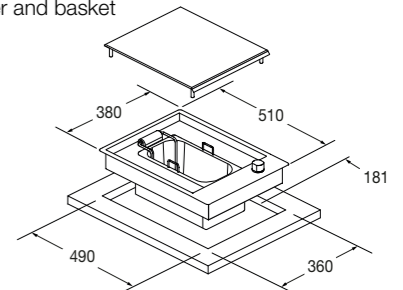

### Features

The fryer features a 1 mm thick edge. This way, it can be flush-mounted or semi-flush-mounted on the kitchen's countertop. This appliance can fry with oil or boil with water. Temperature can be set from 40°C to 200°C. The fryer is fitted with an operation indicator light and a temperature setpoint indicator. It also comes with a black tempered glass cover.

Technical data

page 393



STAINLESS STEEL  
CPH 401 FR X  
EAN 8019801032532

**FULGOR**  
MILANO

**EXTRACTOR AND  
FILTER HOODS FOR THE  
KITCHEN ENVIRONMENT**

**FINALLY FREE FROM  
FUMES AND ODORS**



**FULGOR**  
MILANO

# EXTRACTION

FULGOR extraction hoods are available in different types. The Fulgor cooker hoods are efficient appliances capable of integrating into the kitchen environment, with style.

The entire product line has been designed to ensure a discreet presence and appropriate ventilation. Functional anti-grease filters are easy to remove and dishwasher-safe, assuring comfort and high performance.

## FEATURES

### TOUCH CONTROL

The electronic controls allow to manage the extraction levels, the opening/closure of exhausting area elements, the timer and the filter replacement indicators.

### SOFT-TOUCH CONTROLS

These controls are easy to use and ensure high precision in coordinating all the functions.

### TIMER

The timer allows you to delay the hood operation, even after you finish cooking, eliminating residual fumes and odours from the kitchen.

### LIGHTING

The various lighting systems have been designed to light up the cooking zone and serve as a "courtesy light" in open spaces.



Lift Hood 120

FDDH 1120 TRC X



- Touch controls and remote control
- Electric opening/closing device
- Stainless steel finish
- Power off timer
- LED bar lighting
- Aluminium anti-grease filters
- Filter saturation indicator
- Oil drip tray
- Non-return valve
- Energy Class A

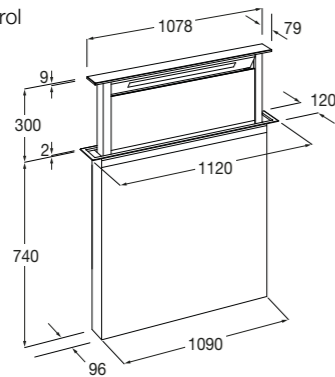

Features

Rear lift hood. **Motors to be ordered separately.** With an FDD 2M motor, the extraction output is 790 m<sup>3</sup>/h (4 power levels). The sound power varies depending on the motor installed.

Accessories on request:

- On-Board motor FDD 2M
- Inner remote motor FEM 1
- Outer remote motor FEM 2
- Activated carbon filter - filtering version use FCHF 12

Accessories on request page 311  
 Technical data page 394



STAINLESS STEEL FDDH 1120 TRC X EAN 8019801022267  
 BLACK GLASS FDDH 1120 TRC BK EAN 8019801022281  
 WHITE GLASS FDDH 1120 TRC WH EAN 8019801022274



Lift Hood 90

FDDH 900 TRC X



- Touch controls and remote control
- Electric opening/closing device
- Stainless steel finish
- Power off timer
- LED bar lighting
- Aluminium anti-grease filters
- Filter saturation indicator
- Oil drip tray
- Non-return valve
- Energy Class A

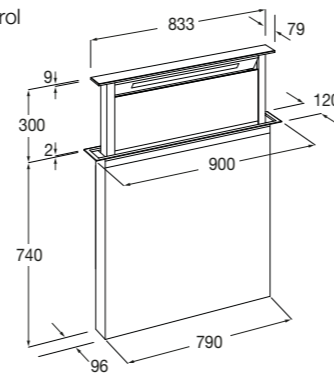

Features

Rear lift hood. **Motors to be ordered separately.** With an FDD 2M motor, the extraction output is 760 m<sup>3</sup>/h (4 power levels). The sound power varies depending on the motor installed.

Accessories on request:

- On-Board motor FDD 2M
- Inner remote motor FEM 1
- Outer remote motor FEM 2
- Activated carbon filter - filtering version use FCHF 9

Accessories on request page 311  
 Technical data page 394



STAINLESS STEEL FDDH 900 TRC X EAN 8019801022298  
 BLACK GLASS FDDH 900 TRC BK EAN 8019801022311  
 WHITE GLASS FDDH 900 TRC WH EAN 8019801022304



Wall-mounted hood 90

FCLHD 900 TC BK



- Touch controls
- Black Glass
- Extraction output: 760 m<sup>3</sup>/h
- 4 suction levels
- Power off timer
- Sound power from 49 to 71 dBA
- LED bar lighting
- Aluminium anti-grease filters
- Filter saturation indicator
- Non-return valve
- Energy Class A+

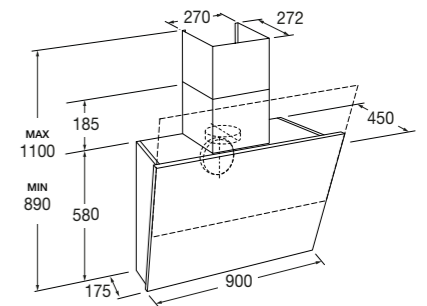

Features

This hood is the kitchen's central element. It offers innovative use solutions. The touch control operates the extraction surface opening system. This system removes all fumes, odours, and excessive heat and humidity during the cooking process.

The auto-power off function and the filter replacement indicators complete the list of functions.

Inclined glass panel with electronic opening, visible design with an adjustable telescopic chimney, automatic opening/closing.

Accessories on request:

- HP activated carbon filter - filtering version use FCHF 18

Accessories on request page 311  
 Technical data page 395

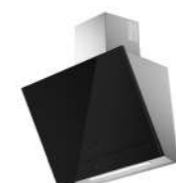

BLACK GLASS FCLHD 900 TC BK EAN 8019801021208



**Central Top Hood 52**

FPHD 52 TS BK



- Touch controls
- Black Glass Ceramic finish
- Hood with an electric opening/closing device
- Extraction output 700 m³/h
- Extraction power: 5 levels
- Power off timer
- Sound power from 55 to 70 dBA
- Aluminium anti-grease filter
- Filter saturation indicator with oil drip tray
- Non-return valve
- Energy Class A+

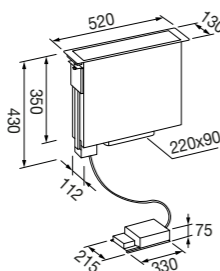

**Features**

Cooktop hood fitted with touch and flap controls and electronic opening/closing system. It can be installed between two induction hobs. This hood ensures high performance even in a small installation area. The anti-grease filters are dishwasher-safe.

Accessories on request:

- HP activated carbon filter - filtering version use FCHF 45

Accessories on request page 311  
 Technical data page 396



BLACK GLASS CERAMIC  
 FPHD 52 TS BK  
 EAN 8019801022380



**Central Top Hood 51**

FPHD 51 TS X



- Touch controls
- Stainless steel finish
- Hood with an electric opening/closing device
- Extraction output 700 m³/h
- Extraction power: 5 levels
- Power off timer
- Sound power from 55 to 70 dBA
- Aluminium anti-grease filter
- Filter saturation indicator with oil-collection tray
- Non-return valve
- Energy Class A+

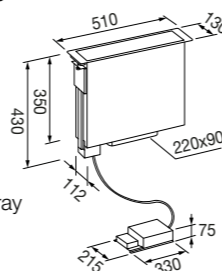

**Features**

Cooktop hood fitted with touch and flap controls and electronic opening/closing system. It can be installed between two induction hobs. This hood ensures high performance even in a small installation area. The anti-grease filters are dishwasher-safe.

Accessories on request:

- HP activated carbon filter - filtering version use FCHF 45

Accessories on request page 311  
 Technical data page 396



STAINLESS STEEL  
 FPHD 51 TS X  
 EAN 8019801022373



**Ceiling-mounted hood 120**

FCHD 1200 RC X



- The functions are enabled via remote control
- Stainless steel finish
- Extraction output: 610 m³/h
- 4 suction levels
- Power off timer
- Sound power from 53 to 64 dBA
- LED lighting
- Aluminium anti-grease filters
- Filter saturation indicator
- Non-return valve
- Energy Class B

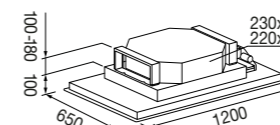

**Features**

Ceiling-mounted hood with perimetral extraction (air is extracted along the light panel perimeter). Controls enabled via remote control. Removable light panel for cleaning anti-grease and carbon filters. The anti-grease filters are dishwasher-safe. Also available in white satin-finish glass.

Accessories on request:

- HP activated carbon filter - filtering version use FCHF 2

Accessories on request page 311  
 Technical data page 397



STAINLESS STEEL  
 FCHD 1200 RC X  
 EAN 8019801023011



WHITE GLASS  
 FCHD 1200 RC WH  
 EAN 8019801023035



**Ceiling-mounted hood 90**

FCHD 900 RC X



- The functions are enabled via remote control
- Stainless steel finish
- Extraction output: 600 m³/h
- 4 suction levels
- Power off timer
- Sound power from 53 to 64 dBA
- LED lighting
- Aluminium anti-grease filters
- Filter saturation indicator
- Non-return valve
- Energy Class B

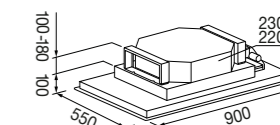

**Features**

Ceiling-mounted hood with perimetral extraction (air is extracted along the light panel perimeter). Controls enabled via remote control. Removable light panel for cleaning anti-grease and carbon filters. The anti-grease filters are dishwasher-safe. Also available in white satin-finish glass.

Accessories on request:

- HP activated carbon filter - filtering version use FCHF 2

Accessories on request page 311  
 Technical data page 397



STAINLESS STEEL  
 FCHD 900 RC X  
 EAN 8019801023004



WHITE GLASS  
 FCHD 900 RC WH  
 EAN 8019801023028



Island hood 120

FTIHD 1260 TC X



- Stainless steel touch controls
- Stainless steel finish
- Extraction output: 730 m³/h
- 4 suction levels
- Power off timer
- Sound power from 47 to 72 dBA
- Double LED bar lighting
- Baffle anti-grease filters
- Filter saturation indicator
- Non-return valve
- Energy Class A

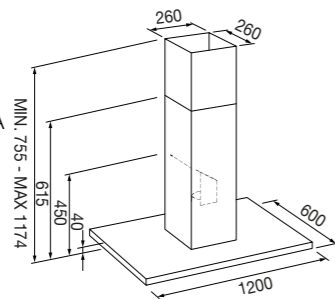

Features

T-shaped hood for island installation (120X60) with adjustable telescopic chimney. The baffle anti-grease filters ensure maximum efficiency. The LED bars ensure optimal hob illumination and can be used as a courtesy light. The anti-grease filters are dishwasher-safe.

Accessories on request:

- HP activated carbon filter - filtering version use FCHF 49

Accessories on request page 311  
 Technical data page 398



STAINLESS STEEL  
 FTIHD 1260 TC X  
 EAN 8019801023127



Island hood 90

FTIHD 960 TC X



- Stainless steel touch controls
- Stainless steel finish
- Extraction output: 730 m³/h
- 4 suction levels
- Power off timer
- Sound power from 47 to 72 dBA
- Double LED bar lighting
- Baffle anti-grease filters
- Filter saturation indicator
- Non-return valve
- Energy Class A

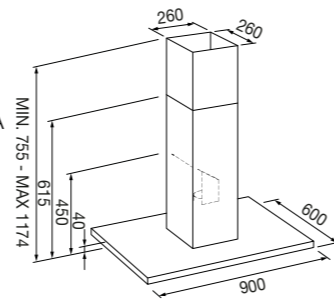

Features

T-shaped hood for island installation (90X60) with adjustable telescopic chimney. The baffle anti-grease filters ensure maximum efficiency. The LED bars ensure optimal hob illumination and can be used as a courtesy light. Also available with a black or white front glass panel. The anti-grease filters are dishwasher-safe.

Accessories on request:

- HP activated carbon filter - filtering version use FCHF 49

Accessories on request page 311  
 Technical data page 398



STAINLESS STEEL BLACK GLASS WHITE GLASS  
 FTIHD 960 TC X FTIHD 960 TC BK X FTIHD 960 TC WH X  
 EAN 8019801023097 EAN 8019801023103 EAN 8019801023110



Wall-mounted hood 120

FTHD 1200 TC X



- Stainless steel touch controls
- Stainless steel finish
- Extraction output: 730 m³/h
- Extraction power: 5 levels
- Power off timer
- Sound power from 47 to 72 dBA
- LED bar lighting
- Baffle anti-grease filters
- Filter saturation indicator
- Non-return valve
- Energy Class A

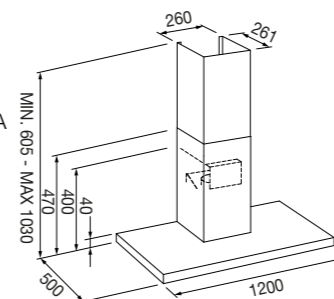

Features

The T-shaped wall-mounted hood's top can be used as a support base for kitchen utensils. It features high-efficiency baffle anti-grease filters. The LED bar ensures optimal illumination of the hob and can be used as a courtesy light. The anti-grease filters are dishwasher-safe.

Accessories on request:

- HP activated carbon filter - filtering version use FCHF 49

Accessories on request page 311  
 Technical data page 399



STAINLESS STEEL  
 FTHD 1200 TC X  
 EAN 8019801023080



Wall-mounted hood 90

FTHD 900 TC X



- Stainless steel touch controls
- Stainless steel finish
- Extraction output: 730 m³/h
- 4 suction levels
- Power off timer
- Sound power from 47 to 72 dBA
- LED bar lighting
- Baffle anti-grease filters
- Filter saturation indicator
- Non-return valve
- Energy Class A

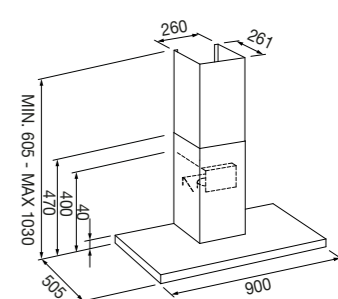

Features

The T-shaped wall-mounted hood's top can be used as a support base for kitchen utensils. It features high-efficiency baffle anti-grease filters. The LED bar ensures optimal illumination of the hob and can be used as a courtesy light. The anti-grease filters are dishwasher-safe. Also available with a black or white glass front panel.

Accessories on request:

- HP activated carbon filter - filtering version use FCHF 49

Accessories on request page 311  
 Technical data page 399



STAINLESS STEEL BLACK GLASS WHITE GLASS  
 FTHD 900 TC X FTHD 900 TC BK X FTHD 900 TC WH X  
 EAN 8019801023059 EAN 8019801023066 EAN 8019801023073



**Integrated hood 90**

FBHD 900 PT X



- Soft touch controls
- Stainless steel finish
- Extraction output: 700 m³/h
- 4 suction levels
- Power off timer
- Sound power from 47 to 70 dBA
- LED lighting
- Aluminium anti-grease filters
- Filter saturation indicator
- Non-return valve
- Energy Class A

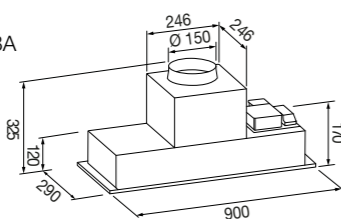

**Features**

Built-In hood. With stainless steel perimetral extraction (air is extracted along the centre panel's perimeter). This hood features 4 LED lights, whereas the part above is discreetly inside the wall unit, although remaining easily accessible for maintenance purposes. The anti-grease filters are dishwasher-safe.

Accessories on request:

- HP activated carbon filter - filtering version use FCHF 13

Accessories on request page 311  
 Technical data page 400



STAINLESS STEEL  
 FBHD 900 PT X  
 EAN 8019801023134



**Integrated hood 70**

FBHD 700 PT X



- Soft touch controls
- Stainless steel finish
- Extraction output: 700 m³/h
- 4 suction levels
- Power off timer
- Sound power from 47 to 70 dBA
- LED lighting
- Filter saturation indicator
- Aluminium anti-grease filters
- Non-return valve
- Energy Class A

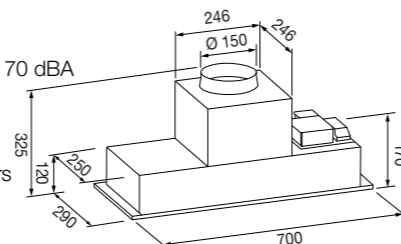

**Features**

Built-In hood. With stainless steel perimetral extraction (air is extracted along the centre panel's perimeter). This hood features 4 LED lights, whereas the part above is discreetly inside the wall unit, although remaining easily accessible for maintenance purposes. The anti-grease filters are dishwasher-safe.

Accessories on request:

- HP activated carbon filter - filtering version use FCHF 13

Accessories on request page 311  
 Technical data page 400



STAINLESS STEEL  
 FBHD 700 PT X  
 EAN 8019801023141



**Integrated hood 80**

FBGHD 800 PT X



- Soft touch controls
- White satin-finish glass finish
- Extraction output: 700 m³/h
- 4 suction levels
- Power off timer
- LED bar lighting
- Aluminium anti-grease filters
- Filter saturation indicator
- Non-return valve
- Sound power from 47 to 70 dBA
- Energy Class A

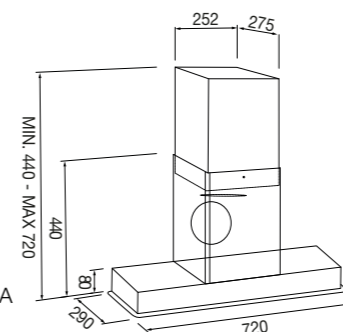

**Features**

Built-In hood. With satin-finish glass perimetral extraction. (air is extracted along the centre panel's perimeter). The LED bar illuminates the hob optimally, the upper and functional elements are integrated inside the wall unit but easy to access for maintenance purposes. The anti-grease filters are dishwasher-safe.

Accessories on request:

- HP activated carbon filter - filtering version use FCHF 13

Accessories on request page 311  
 Technical data page 400



STAINLESS STEEL  
 FBGHD 800 PT X  
 EAN 8019801023158



**Integrated hood 85**

FBGHD 850 TC X



- Touch controls
- Stainless steel finish
- Extraction output: 780 m³/h
- 4 suction levels
- Power off timer
- LED bar lighting
- Aluminium anti-grease filters
- Filter saturation indicator
- Non-return valve
- Sound power from 45 to 71 dBA
- Energy Class A+

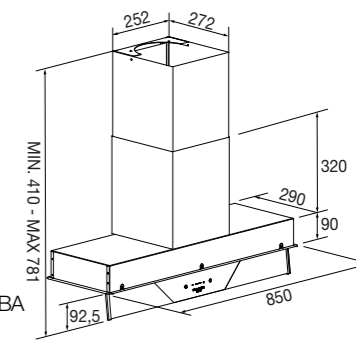

**Features**

Hood to be installed into a cabinet with retractable clear glass visor including touch controls.. The LED bar illuminates the hob optimally, the upper and functional elements are integrated inside the wall unit but easy to access for maintenance purposes. The anti-grease filters are dishwasher-safe.

Accessories on request:

- HP activated carbon filter - filtering version use FCHF 8

Accessories on request page 311  
 Technical data page 400



STAINLESS STEEL  
 FBGHD 850 TC X  
 EAN 8019801023042

**FULGOR**  
MILANO

## REFRIGERATORS AND FREEZERS

EVERYTHING WAS FROZEN  
EVEN THE NOISE

(JULES VERNE)



**FULGOR**  
MILANO

**FULGOR**  
MILANO

# REFRIGERATION



## REFRIGERATORS AND FREEZERS

Fulgor Milano presents a wide range of exclusive refrigerators and freezers fitted with the latest functions to keep food fresh or frozen under perfect conditions. All FULGOR MILANO refrigerators and freezers add functionality to a healthy and modern lifestyle. Accurate electronic controls and optimized cooling circuits allow us to provide energy-efficient products.



## 30" Combined Refrigerator

FBCD 761 TNF EDBL



- Built-in installation
- Panel-ready refrigerator
- Total No Frost cooling
- Digital display
- Total gross capacity: 460 litres
- Fast Freezing Function
- Holiday function
- Automatic defrosting
- Interior LED lighting
- Self-supporting hinges + Reversible doors
- Energy Class: E (ex A++)

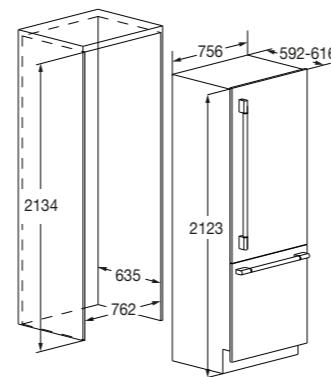

### Features

TOTAL NO FROST refrigerator with LED lighting, fitted with a special Fresh drawer and fine stainless steel finishes. This also has three glass shelves and three balconies on the counterdoor with an egg rack. The freezer has three removable drawers and solid telescopic guides. Independent temperature regulation between the refrigerator and freezer. This refrigerator features an open-door buzzer, a temperature indicator light, and a quick freezer indicator light.

Accessories sold separately:

- |  |                 |
|--|-----------------|
| - Door kit stainless steel             | F4PANEL30BMSS   |
| - Door kit black                       | F4PANEL30BMUMBK |
| - Professional Handle Kit              | F4HKPRO30BM     |
| - Urbantech stainless steel handle kit | F4HKU30BMSS     |
| - Urbantech black handle kit           | F4HKU30BMMBK    |

Accessories on request  
Technical data

page 309  
page 401



- |                    |                        |                   |                   |                   |                   |
|--------------------|------------------------|-------------------|-------------------|-------------------|-------------------|
| COMBI REFRIGERATOR | STAINLESS STEEL PANELS | BLACK PANELS      | PRO HANDLES       | URB HANDLES       | URB HANDLES       |
| FBCD 761 TNF EDBL  | F4PANEL30BMSS          | F4PANEL30BMUMBK   | F4HKPRO30BM       | F4HKU30BMSS       | F4HKU30BMMBK      |
| EAN 8019801031481  | EAN 8019801031825      | EAN 8019801032778 | EAN 8019801031832 | EAN 8019801032792 | EAN 8019801032785 |



## 30" Combined Refrigerator

FBCD 762 TNF EDBL



- Built-In installation + Panel-ready refrigerator
- Total No Frost cooling
- Digital display
- Total gross capacity: 460 litres
- Ice Maker + Water dispenser
- Fast Freezing Function
- Holiday function
- Automatic defrosting
- Interior LED lighting
- Self-supporting hinges + Reversible doors
- Energy Class: E (ex A++)

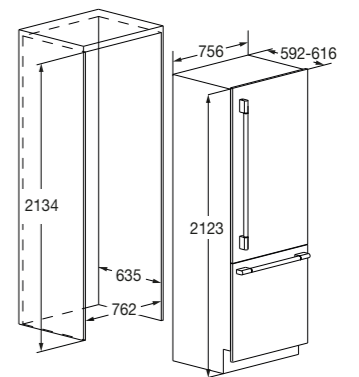

### Features

TOTAL NO FROST refrigerator with LED lighting, fitted with a special Fresh drawer and fine stainless steel finishes. The refrigeration system with two cooling systems cools the food quickly while saving energy. Cold water is always ensured by the internal dispenser. The ice maker inside the freezer allows you to enjoy the amount of ice you want whenever you want. This also has three glass shelves and three balconies on the counterdoor with an egg rack. The freezer has three removable drawers.

Accessories sold separately:

- |  |                 |
|--|-----------------|
| - Door kit stainless steel             | F4PANEL30BMSS   |
| - Door kit black                       | F4PANEL30BMUMBK |
| - Professional Handle Kit              | F4HKPRO30BM     |
| - Urbantech stainless steel handle kit | F4HKU30BMSS     |
| - Urbantech black handle kit           | F4HKU30BMMBK    |

Accessories on request  
Technical data

page 309  
page 401



- |                    |                        |                   |                   |                   |                   |
|--------------------|------------------------|-------------------|-------------------|-------------------|-------------------|
| COMBI REFRIGERATOR | STAINLESS STEEL PANELS | BLACK PANELS      | PRO HANDLES       | URB HANDLES       | URB HANDLES       |
| FBCD 762 TNF EDBL  | F4PANEL30BMSS          | F4PANEL30BMUMBK   | F4HKPRO30BM       | F4HKU30BMSS       | F4HKU30BMMBK      |
| EAN 8019801031498  | EAN 8019801031825      | EAN 8019801032778 | EAN 8019801031832 | EAN 8019801032792 | EAN 8019801032785 |

**FULGOR**  
MILANO

# STORAGE

## CONTROLLING FRESHNESS



### BUILT-IN REFRIGERATORS AND FREEZERS

Fulgor Milano's refrigerators are designed in Italy using top-quality materials and components to last over time. The stainless steel profiles of the glass shelves and door balconies enhance the beauty of the product's finishes. The internal electronic controls and LED lighting are efficient while minimising energy consumption. FULGOR MILANO's freezer freezes food easily and safely. The integrated NoFrost system introduces cold and dry air inside the freezer thanks to a continuous fan. Even air ventilation eliminates humidity, making defrosting unnecessary and maintaining food fresh for longer.

## REFRIGERATION

REFRIGERATORS



### Combined Refrigerator 70

FBCD 701 TNF EDBL



- Built-in installation
- Total No Frost cooling
- Digital display
- Total gross capacity: 350 litres
- Fast Freezing Function
- Holiday function
- Automatic defrosting
- Interior LED lighting
- Self-supporting hinges
- Reversible doors
- Energy Class: E (ex A++)

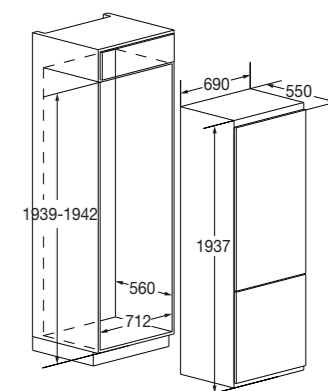

### Features

TOTAL NO FROST combined refrigerator featuring a large backlit rear panel for a unique design. Besides the Produce drawer, the appliance features a Fresh drawer for meat and fish (+-3 °C). This refrigerator also has four glass shelves and three balconies on the counterdoor with an egg rack. The TOTAL NO FROST freezer features three large removable drawers. Independent temperature regulation between the refrigerator and freezer. Moreover, it comes with an open-door buzzer, a temperature indicator and a quick freezer indicator.

Technical data

page 402



COMBINED REFRIGERATOR  
FBCD 701 TNF EDBL  
EAN 8019801030545



## Column Refrigerator 60

FBR 300 F ED



- Built-in installation
- Ventilated cooling
- Digital display
- Total gross capacity: 320 litres
- Temperature regulation
- Automatic static defrosting
- Interior LED lighting
- Sliding door assembly
- Reversible door
- Energy Class: E (ex A+)

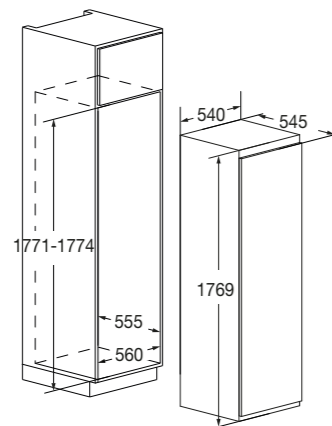

### Features

Spacious single-door refrigerator, whose layout ensures optimal food and beverage arrangement. It is fitted with six glass shelves, two produce drawers, a metal bottle holder (4 positions), five balconies on the counterdoor and an egg rack. The refrigerator features an automatic defrosting system, a temperature indicator, and a memory function in the event of shutdown or power failure.

Technical data

page 403



SINGLE-DOOR REFRIGERATOR  
FBR 300 F ED  
EAN 8019801029464



## Freezer 60

FBF 290 NF ED



- Built-in installation
- Total No Frost cooling
- Digital display
- Total gross capacity: 210 litres
- Fast Freezing Function
- Automatic defrosting
- Internal light
- Sliding door assembly
- Reversible door
- Energy Class: E (ex A+)

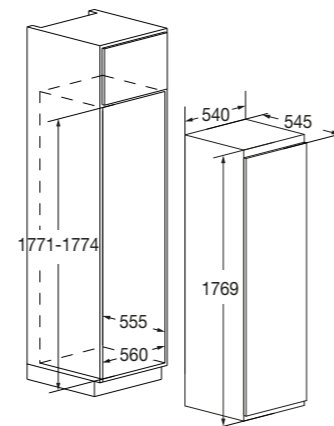

### Features

TOTAL NO FROST column freezer fitted with two flaps and 5 transparent drawers (to check the content). Moreover, it comes with an open-door buzzer, a temperature indicator and a quick freezer indicator. The latter function is used to freeze large amounts of food all at once.

Technical data

page 403



FREEZER  
FBF 290 NF ED  
EAN 8019801029488



## Combined Refrigerator 60

FBC 345 TNF ED



- Built-in installation
- Total No Frost cooling
- Digital display
- Total gross capacity: 252 litres
- Fast Freezing Function
- Holiday function
- Automatic defrosting
- Interior LED lighting
- Sliding door assembly
- Reversible doors
- Energy Class: E (ex A++)

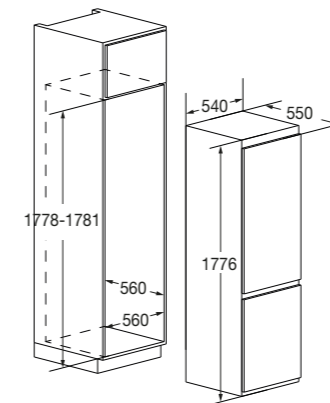

### Features

TOTAL NO FROST combined refrigerator featuring a stainless steel rear conveyor. Besides the Produce drawer, the appliance features a Fresh drawer for meat and fish (+ -3 °C). This refrigerator also has four glass shelves, a metal bottle holder (4 positions), three balconies on the counterdoor, and an egg rack. The TOTAL NO FROST freezer features three large removable drawers. Independent temperature regulation between the refrigerator and freezer. Moreover, it comes with an open-door buzzer, a temperature indicator and a quick freezer indicator.

Technical data

page 402



COMBINED REFRIGERATOR  
FBC 345 TNF ED  
EAN 8019801029440



## Combined Refrigerator 60

FBCD 355 TNF ED



- Built-in installation
- Total No Frost cooling
- Digital display
- Total gross capacity: 252 litres
- Fast Freezing Function
- Holiday function
- Automatic defrosting
- Interior LED lighting
- Self-supporting hinges
- Reversible doors
- Energy Class: E (ex A++)

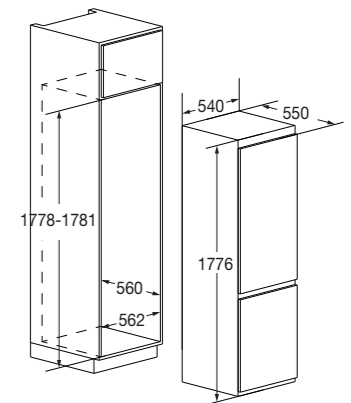

### Features

TOTAL NO FROST combined refrigerator featuring a large backlit rear panel for a unique design. Besides the Produce drawer, the appliance features a Fresh drawer for meat and fish (+ -3 °C). This refrigerator also has four glass shelves and three balconies on the counterdoor with an egg rack. The TOTAL NO FROST freezer features three large removable drawers. Independent temperature regulation between the refrigerator and freezer. Moreover, it comes with an open-door buzzer, a temperature indicator and a quick freezer indicator.

Technical data

page 402



COMBINED REFRIGERATOR  
FBCD 355 TNF ED  
EAN 8019801030538



**Wine Cellar 88**

FWC 8800 TC BKX



- Stainless steel finish
- Digital touch display
- Reversible door
- Capacity: 40 bottles Ø 76 mm
- Ventilated cooling
- Control light indicator
- Interior LED lighting
- Two temperature zones

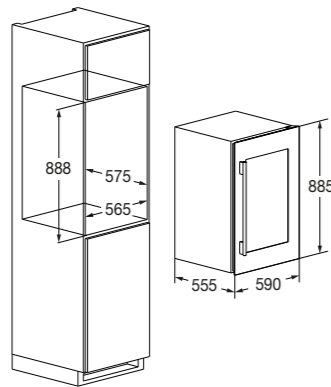

**Features**

The wine cellar column has an upper and lower area and features an independent temperature regulation from +5°C to +20°C. Moreover, the cellar is equipped with antivibration and anticondensation systems and a UV-insulating glass pane. This appliance comes with 5 beech wood sliding shelves (one shelf for 4 champagne bottles) and a fixed lower shelf.

Technical data

page 405



STAINLESS STEEL  
FWC 8800 TC BKX  
EAN 8019801030712



BLACK GLASS  
FWC 8800 TC GBK  
EAN 8019801030705



**Wine Cellar 82**

FWC 8200 U TC BKX



- Stainless steel finish
- Digital touch display
- Reversible door
- Capacity: 39 bottles Ø 76 mm
- Ventilated cooling
- Control light indicator
- Interior LED lighting
- Two temperature zones

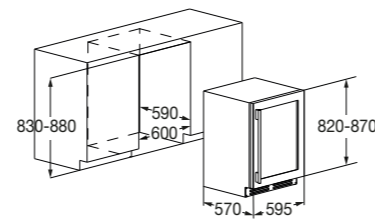

**Features**

The wine cellar column has an upper and lower area and features an independent temperature regulation from +5°C to +20°C. Moreover, the cellar is equipped with antivibration and anticondensation systems and a UV-insulating glass pane. This appliance comes with 4 beech wood sliding shelves (one shelf for 5 champagne bottles) and a fixed lower shelf.

Technical data

page 404



STAINLESS STEEL  
FWC 8200 U TC BKX  
EAN 8019801030699



BLACK GLASS  
FWC 8200 U TC GBK  
EAN 8019801030682



**FULGOR**  
MILANO

**IN EVERY WATER DROP LIES ALL  
THE OCEAN'S SECRETS**

(Khalil Gibran)



**DISHWASHERS**

# DISHWASHING

**FULGOR**  
MILANO



DISHWASHING

DISHWASHING

# DISHWASHERS

**FULGOR**  
MILANO

FULGOR MILANO's integrated dishwashers are designed in Italy. They are the ideal choice for modern design kitchens. Besides being elegant, they are extremely easy to use.



## INTELLIGIBLE CONTROLS

Soft Touch keys and the digital display allow you to select and control FULGOR MILANO dishwasher's programs easily and accurately.

## AUTO-OPEN

The dishwasher door opens automatically once the washing program is complete. Even plastic plates and crystal glasses are perfectly dry. An air duct protects the upper part of the kitchen from humidity.

## ENERSAVE (ECO)

This function reduces energy consumption: the partial and progressive door opening improves drying performance and controls the temperature during the rinsing stage.

## EFFICIENCY

FULGOR MILANO's dishwashers are designed to obtain optimal washing and drying results using a minimum amount of water, detergents, and energy.

## QUICK WASH CYCLE

Combined with other washing cycles, this option can reduce them by 10% to 55%, depending on the selected cycle.

## 3RD RACK

The retractable top drawer (3rd load level) is ideal for placing cutlery and small kitchen utensils. This allows for greater load flexibility.

## PUSH TO OPEN

FULGOR MILANO's dishwashers can be opened by touching the unit's door, which will partially open to allow you to insert and remove plates, pans, and cutlery effortlessly.

## SLIDING HINGE DOOR

The dishwashers are installed seamlessly thanks to a sliding hinge system, which allows concealed insertion of appliances with a base of 25 mm or greater.



## Premium - Fully Integrated 60 Sliding

FDW 82914 TC - SD



- Touch Control
- 14 places settings
- 9 program
- 3 racks
- Antibacterial Filter
- Child Lock
- Soft touch mug shelf + Bottle holder
- Internal sprayer made in stainless steel
- Infoled and interior light
- Noise level 42 dB (A)
- Energy class A

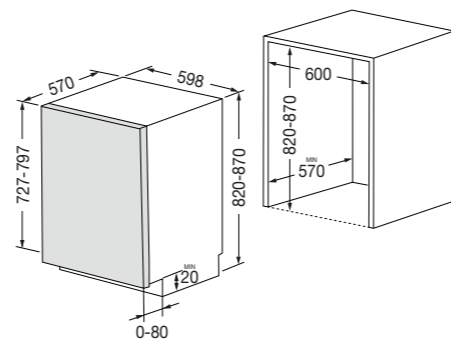

### Features

This dishwasher in "A" class, combines the most high technology and performances in terms of energy saving, noise level and efficiency. 3 racks levels, half-load for all programs. The touch control panel allows to the users to select the washing program very easily and warns them when salt and rinse aid are running out. Sound emission of 42 dB (A) ; the inverter motor allows to adjust the speed and energy consumption according selected program. The safety devices include AcquaStop, child lock and Machine Clean Programme. This dishwasher is also equipped with an innovative "Soft Touch" support that protects glasses from scratches and damages, reducing noise and vibrations during operation. Thanks to the Sliding hinges, the dishwasher door panel can be installed with a plinth starting from just 2 cm from the floor, as the cabinet panel slides over the dishwasher door during opening, ensuring greater flexibility in kitchen design.

Technical data

page 406



INTEGRATED 60  
FDW 82914 TC - SD  
EAN 8019801036509



## Premium - Fully Integrated 60

FDW 82914 TC



- Touch Control
- 14 places settings
- 9 program
- 3 racks
- Antibacterial Filter
- Child Lock
- Infoled and interior light
- Noise level 42 dB (A)
- Internal sprayer made in S. steel
- Soft touch mug shelf + Bottle holder
- Energy class A

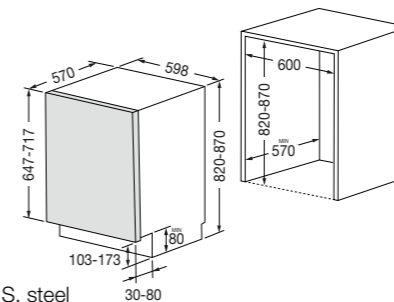

### Features

This dishwasher in "A" class, combines the most high technology and performances in terms of energy saving, noise level and efficiency. 3 racks levels, half-load for all programs. The touch control panel allows to the users to select the washing program very easily and warns them when salt and rinse aid are running out. Sound emission of 42 dB (A); the inverter motor allows to adjust the speed and energy consumption according selected program. The safety devices include AcquaStop, child lock and Machine Clean Programme. This dishwasher is also equipped with an innovative "Soft Touch" support that protects glasses from scratches and damages, reducing noise and vibrations during operation.

Technical data

page 406



INTEGRATED 60 SLIDING  
FDW 82914 TC  
EAN 8019801034574



## Premium - Fully Integrated 60

FDW 82914 PB



- Touch Control
- 14 places settings
- 9 program
- 3 racks
- Antibacterial Filter
- Child Lock
- Infoled and interior light
- Noise level 42 dB (A)
- Internal sprayer made in S. steel
- Soft touch mug shelf + Bottle holder
- Energy class A

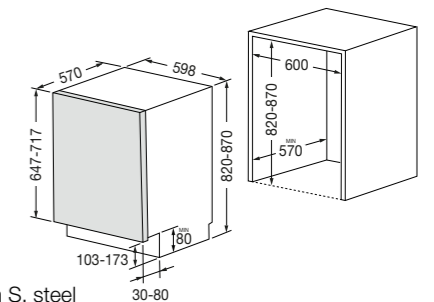

### Features

This dishwasher in "A" class, combines the most high technology and performances in terms of energy saving, noise level and efficiency. 3 racks levels, half-load for all programs. The touch control panel allows to the users to select the washing program very easily and warns them when salt and rinse aid are running out. Sound emission of 42 dB (A); the inverter motor allows to adjust the speed and energy consumption according selected program. The safety devices include AcquaStop, child lock and Machine Clean Programme. This dishwasher is also equipped with an innovative "Soft Touch" support that protects glasses from scratches and damages, reducing noise and vibrations during operation.

Technical data

page 407



INTEGRATED 60  
FDW 82914 PB  
EAN 8019801034598

# SINKS

## BEAUTY AND FUNCTIONALITY

FULGOR MILANO's kitchen sinks stand out for their advanced yet minimalist design. Its range includes: double-bowl sinks, single-bowl sinks, flush sinks, semi-flush sinks, and undermount sinks, all available in various sizes. The AISI 304 stainless steel bowls (10/10 thick) feature a unique satin finish. Three matching satin-finish stainless steel mixers complete the range.

**FULGOR**  
MILANO



### FLUSH-MOUNTED

The 45 and 51 ranges can be flush mounted to create a smooth, continuous countertop.

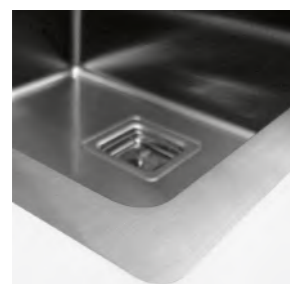

### SEMI-FLUSH-MOUNTED

The 45 and 51 ranges can be semi-flush mounted thanks to their 1 mm thickness.



### UNDER MOUNTED

The U range undermount sinks perfectly merge with the kitchen's countertop.



### STAINLESS STEEL COLANDER

The perfect accessory to wash fruits and vegetables and drain pasta, rice, and grains and vegetables.



### CHOPPING BOARD

Made with long-lasting material, this chopping board is suitable for chopping and slicing any food.



### MIXERS

This AISI 316 stainless steel progressive mixers perfectly combine with Fulgor Milano's sinks. They can also be installed outside the bowl.



### MICRO-PERFORATED TRAYS

Stainless steel trays available in two sizes, suitable for separating food from the cooking water.

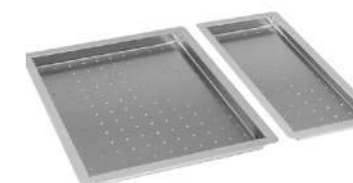



Mixer

FOMT 521 X



- AISI 316 L stainless steel
- With black hose
- 2-jet hand-held shower

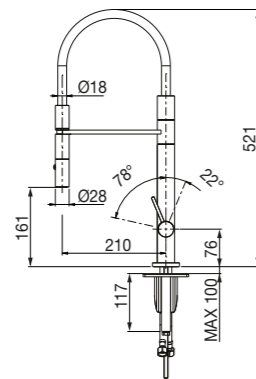

Features

This mixer stands out for its unique design. It's fitted with a removable 2-jet hand-held shower head, useful for washing kitchenware. The matte brushed stainless steel (AISI 316 L) finish perfectly blends in a modern kitchen. It also has a 180° swivel spout, a black hose, and a control lever.



STAINLESS STEEL  
FOMT 521 X  
EAN 801981027859



Mixer

FOMT 300 X



- AISI 316 L stainless steel
- With swivel spout

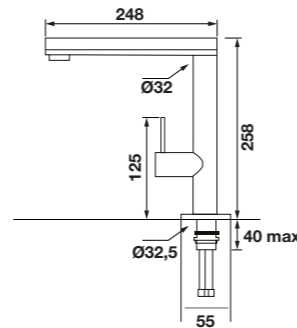

Features

Brushed stainless steel mixer (AISI 316 L) with swivel spout. Fulgor Milano's products are made with stainless steel, a perfect material in the kitchen. Minimalist mixer with a single lever.



STAINLESS STEEL  
FOMT 300 X  
EAN 8019801027866



Mixer

FOMT 600 X



- AISI 316 L stainless steel
- Hand-held shower head

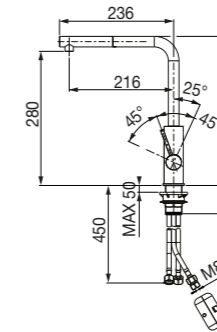

Features

Brushed AISI 316 L. stainless steel mixer. Fulgor Milano's products are made with stainless steel, a perfect material in the kitchen. Minimalist mixer with a single lever.



STAINLESS STEEL  
FOMT 600 X  
EAN 8019801032662



Flush-mount and semi-flush-mount sinks 85

P1B 8545 Q F SF



- Acciaio inox AISI 304 con finit. satinata
- Base 900 mm
- Vasca grande singola
- Raggio 10 per installazione
- Profondità vasca 200 mm

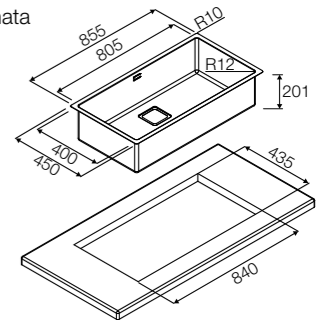

Features

The elegant satin AISI 304 stainless steel finish perfectly blends in a modern kitchen, as it combines aesthetics with functionality. This 1 mm thick bowl can be flush-mount or semi-flush-mount. It comes with the following accessories: a square one-way drain plug and a one-way siphon.



SATIN-FINISH STAINLESS STEEL  
P1B 8545 Q F SF  
EAN 8019801011216



Flush-mount and semi-flush-mount sinks **75**  
P1B 7545 Q F SF



- AISI 304 L stainless steel with satin finish
- 800 mm base
- Large single bowl
- Radius 10 for installation
- Bowl depth: 200 mm

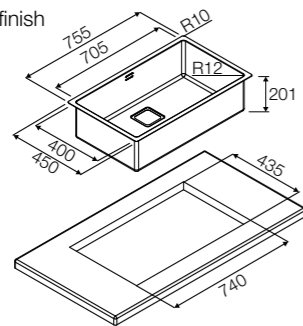

**Features**

This 1 mm thick bowl can be flush-mount or semi-flush-mount. The elegant satin AISI 304 stainless steel finish perfectly blends in a modern kitchen, as it combines aesthetics with functionality. It comes with the following accessories: a square one-way drain plug and a one-way siphon.



SATIN-FINISH STAINLESS STEEL  
P1B 7545 Q F SF  
EAN 8019801011162



Flush-mount and semi-flush-mount sinks **55**  
P1B 5545 Q F SF



- AISI 304 L stainless steel with satin finish
- 600 mm base
- Single bowl
- Radius 10 for installation
- Bowl depth: 200 mm

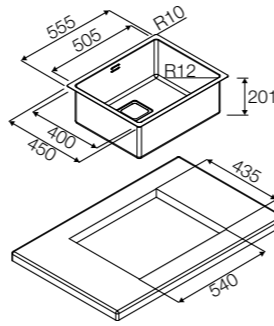

**Features**

This 1 mm thick bowl can be flush-mount or semi-flush-mount. The elegant satin AISI 304 stainless steel finish perfectly blends in a modern kitchen, as it combines aesthetics with functionality. It comes with the following accessories: a square one-way drain plug and a one-way siphon.



SATIN-FINISH STAINLESS STEEL  
P1B 5545 Q F SF  
EAN 8019801011179



Flush-mount and semi-flush-mount sinks **86**  
P1B 8651 QA F SF



- AISI 304 L stainless steel with satin finish
- 900 mm base
- Large single bowl
- Radius 10 for installation
- Bowl depth: 200 mm
- Mixer set up

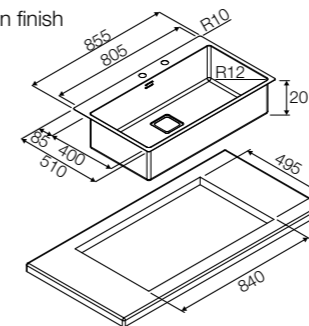

**Features**

The elegant satin AISI 304 stainless steel finish perfectly blends in a modern kitchen, as it combines aesthetics with functionality. This 1 mm thick bowl can be flush-mount or semi-flush-mount. It comes with the following accessories: a square one-way drain plug and a one-way siphon.



SATIN-FINISH STAINLESS STEEL  
P1B 8651 QA F SF  
EAN 8019801011247



Flush-mount and semi-flush-mount sinks **56**  
P1B 5651 QA F SF



- AISI 304 L stainless steel with satin finish
- 600 mm base
- Single bowl
- Radius 10 for installation
- Bowl depth: 200 mm
- Mixer set up

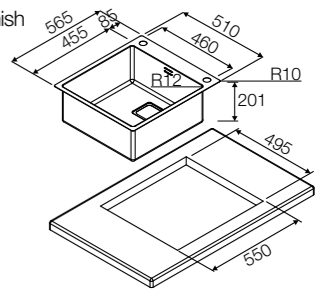

**Features**

This 1 mm thick bowl can be flush-mount or semi-flush-mount. The elegant satin AISI 304 stainless steel finish perfectly blends in a modern kitchen, as it combines aesthetics with functionality. It comes with the following accessories: a square one-way drain plug and a one-way siphon.



SATIN-FINISH STAINLESS STEEL  
P1B 5651 QA F SF  
EAN 8019801011254



Flush-mount and Top semi-flush-mount sinks **85**  
P2B 8545 Q F SF



Flush-mount and Top semi-flush-mount sinks **55**  
P2B 5545 Q F SF R



Flush-mount and Top semi-flush-mount sinks **86**  
P2B 8651 QA F SF



Flush-mount and Top semi-flush-mount sinks **76**  
P2B 7651 QA F SF



- AISI 304 L stainless steel with satin finish
- 900 mm base
- Double bowl
- Radius 10 for installation
- Bowl depth: 200 mm

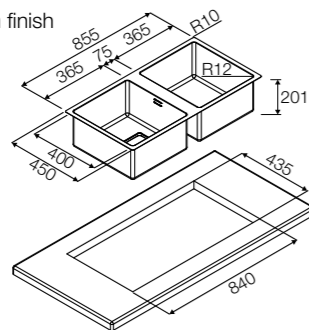

**Features**

The double-bowl sink perfectly blends with a modern kitchen style thanks to the AISI 304 stainless steel finish. This 1 mm thick sink can be flush-mount or semi-flush-mount. It comes with the following accessories: squared two-way overflow drain plug and a two-way siphon.



- Aisi 304 L stainless steel with satin finish
- 600 mm base
- Double bowl
- Radius 10 for installation
- Bowl depth: 200 mm

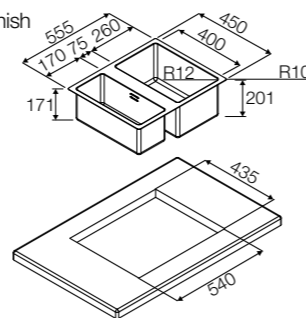

**Features**

Asymmetric double-bowl sink made with an elegant satin AISI 304 stainless steel finish that perfectly blends with a modern kitchen style, combining aesthetics with functionality. This 1 mm thick sink can be flush-mount or semi-flush-mount. It comes with the following accessories: squared two-way overflow drain plug and a two-way siphon.



- Aisi 304 L stainless steel with satin finish
- 900 mm base
- Double bowl
- Radius 10 for installation
- Bowl depth: 200 mm
- Mixer set up

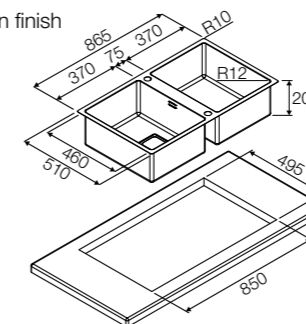

**Features**

Double-bowl sink made with a satin AISI 304 stainless steel finish that perfectly blends in a modern kitchen, as it combines aesthetics with functionality. This 1 mm thick sink can be flush-mount or semi-flush-mount. It comes with the following accessories: squared two-way overflow drain plug and a two-way siphon.



- Aisi 304 L stainless steel with satin finish
- 800 mm base
- Double bowl
- Radius 10 for installation
- Bowl depth: 200 mm
- Mixer set up

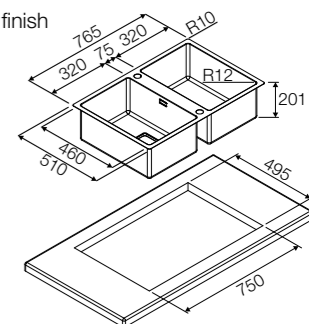

**Features**

Double-bowl sink that perfectly blends in a modern kitchen thanks to the AISI 304 stainless steel finish. Thanks to the 1 mm thick steel, it can be flush-mount or semi-flush-mount. It comes with the following accessories: squared two-way overflow drain plug and a two-way siphon.



SATIN-FINISH STAINLESS STEEL  
P2B 8545 Q F SF  
EAN 8019801011148



SATIN-FINISH STAINLESS STEEL  
P2B 5545 Q F SF R  
EAN 8019801011155



SATIN-FINISH STAINLESS STEEL  
P2B 8651 QA F SF  
EAN 8019801011223



SATIN-FINISH STAINLESS STEEL  
P2B 7651 QA F SF  
EAN 8019801011230



**Undermount sink**

83

P1B 8343 Q U



- Aisi 304 L stainless steel with satin finish
- 900 mm base
- Large single bowl
- Radius 10 for installation
- Bowl depth: 200 mm

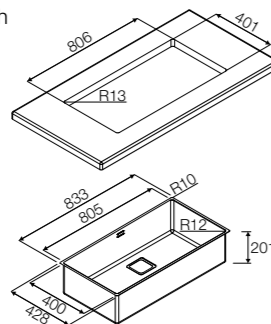

**Features**

The elegant satin AISI 304 stainless steel finish perfectly blends in a modern kitchen, as it combines aesthetics with functionality. This large bowl is mounted underneath the worktop to provide continuity between the bowl and the worktop. It comes with the following accessories: a square one-way drain plug and a one-way siphon.



SATIN-FINISH STAINLESS STEEL  
P1B 8343 Q U  
EAN 8019801011285



**Undermount sink**

73

P1B 7343 Q U



- Aisi 304 L stainless steel with satin finish
- 800 mm base
- Large single bowl
- Radius 10 for installation
- Bowl depth: 200 mm

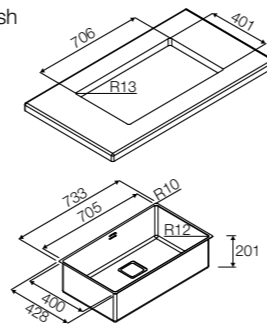

**Features**

This large bowl is mounted underneath the worktop to provide continuity between the bowl and the worktop. The elegant satin AISI 304 stainless steel finish perfectly blends in a modern kitchen, as it combines aesthetics with functionality. It comes with the following accessories: a square one-way drain plug and a one-way siphon.



SATIN-FINISH STAINLESS STEEL  
P1B 7343 Q U  
EAN 8019801011292



**Undermount sink**

53

P1B 5343 Q U



- Aisi 304 L stainless steel with satin finish
- 600 mm base
- Large single bowl
- Radius 10 for installation
- Bowl depth: 200 mm

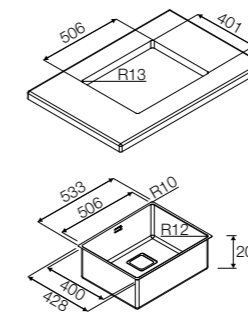

**Features**

Single bowl sink with a satin AISI 304 stainless steel finish that perfectly blends in a modern kitchen, as it combines aesthetics with functionality. This large bowl is mounted underneath the worktop to provide continuity between the bowl and the worktop. It comes with the following accessories: a square one-way drain plug and a one-way siphon.



SATIN-FINISH STAINLESS STEEL  
P1B 5343 Q U  
EAN 8019801011308



**Undermount sink**

83

P2B 8343 Q U



- Aisi 304 L stainless steel with satin finish
- 900 mm base
- Double bowl
- Radius 10 for installation
- Bowl depth: 200 mm

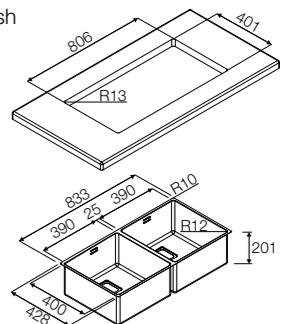

**Features**

Two-bowl sink with a satin AISI 304 stainless steel finish that perfectly blends in a modern kitchen. It is mounted underneath the worktop to provide continuity between the bowl and the worktop. It comes with the following accessories: automatic squared 2-way overflow drain plug and a two-way siphon.



SATIN-FINISH STAINLESS STEEL  
P2B 8343 Q U  
EAN 8019801011261

PROFESSIONAL  
**ACCESSORIES**  
ON REQUEST

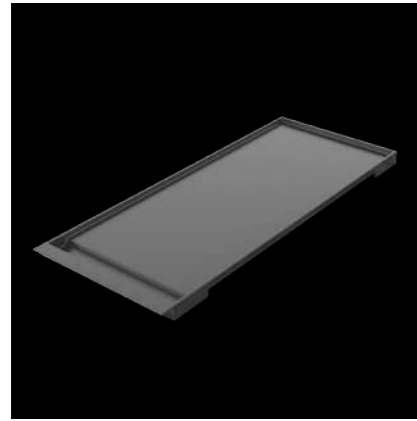

Robust 36" cast iron griddle

COD **FM GRID 36**  
EAN 8019801017133

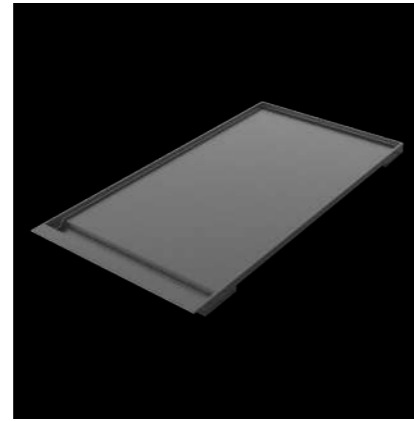

Robust 30" cast iron griddle

COD **FM GRID 30**  
EAN 8019801017126

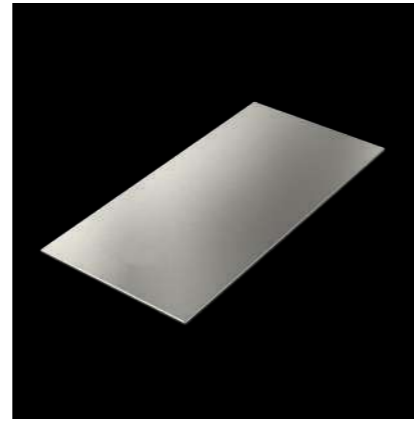

Stainless steel Teppanyaki plate (trilaminated)

COD **TY PLATE X**  
EAN 8019801030415



Cast-iron wok adapter

COD **FMWOK**  
EAN 8019801016914

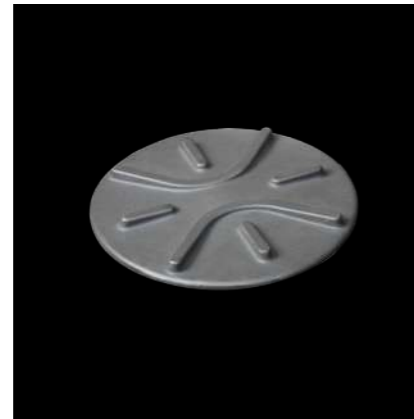

Cast iron adapter for low-temperature cooking

COD **FMSIM**  
EAN 8019801016921



36" telescopic rack

COD **FMTRP36**  
EAN 8019801018499



30" telescopic rack

COD **FMTRP30**  
EAN 8019801018482

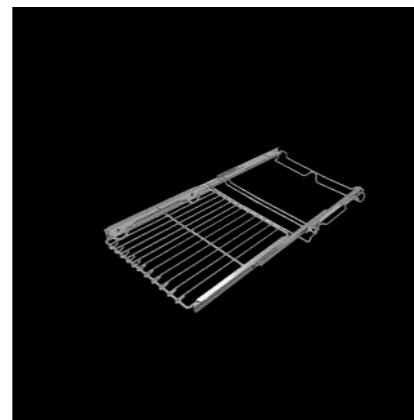

18" telescopic rack

COD **FMTRP18**  
EAN 8019801019885



Steel hood chimney kit FPRHD 482 TC

COD **FPRHD 482 KIT X**  
EAN 8019801022052

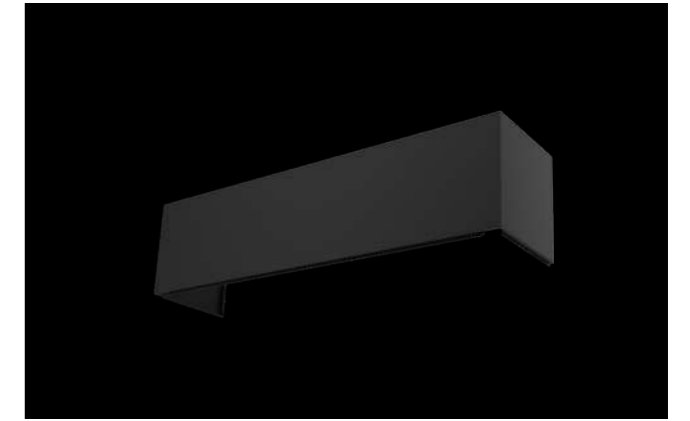

Matte black hood chimney kit FPRHD 482 TC

COD **FPRHD 482 KIT MBK**  
EAN 8019801022090



Steel hood chimney kit FPRHD 362 TC

COD **FPRHD 362 KIT X**  
EAN 8019801022045



Matte black hood chimney kit FPRHD 362 TC

COD **FPRHD 362 KIT MBK**  
EAN 8019801022083

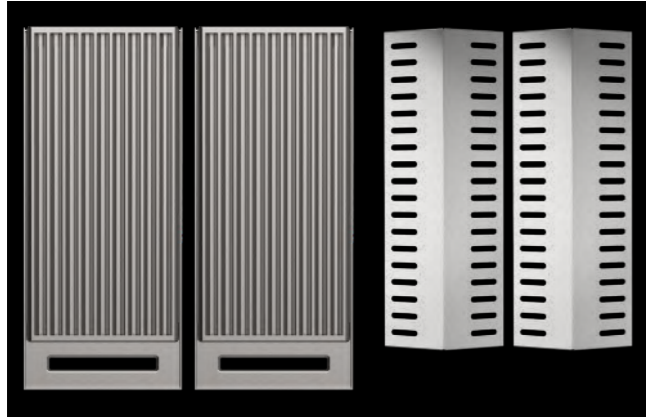

Two stainless steel grates with heat diffusers

COD **FOBQ GRT X**  
EAN 8019801021956

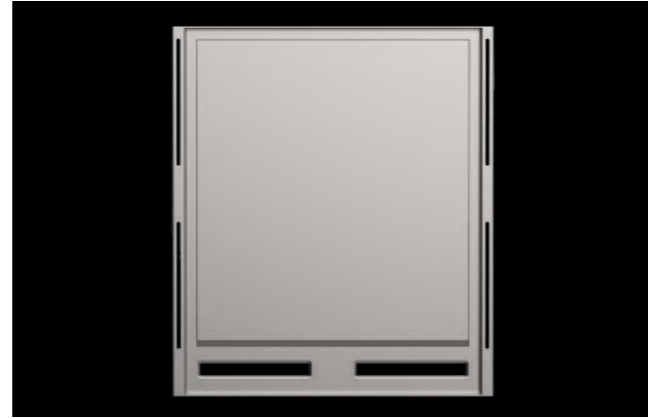

Stainless steel Teppanyaki griddle

COD **FOBQ TY X**  
EAN 8019801021970

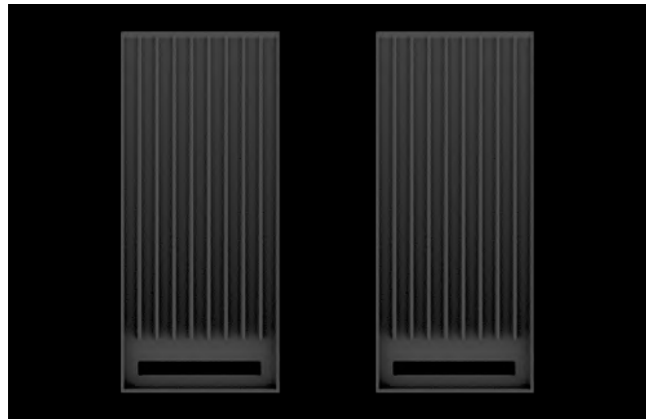

Cast-iron ribbon griddles

COD **FOBQ GRT CAST**  
EAN 8019801021963



Cast-iron Teppanyaki griddle

COD **FOBQ TY CAST**  
EAN 8019801021987

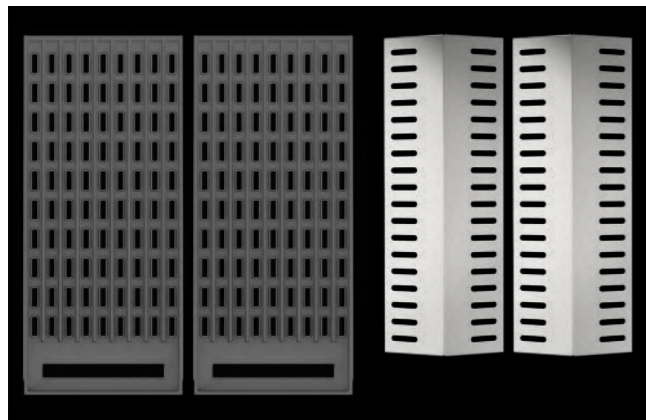

Two perforated cast iron grates with heat diffusers

COD **FOBQ GRT H CAST**  
EAN 8019801031566

# ACCESSORIES ON REQUEST OTHER RANGES

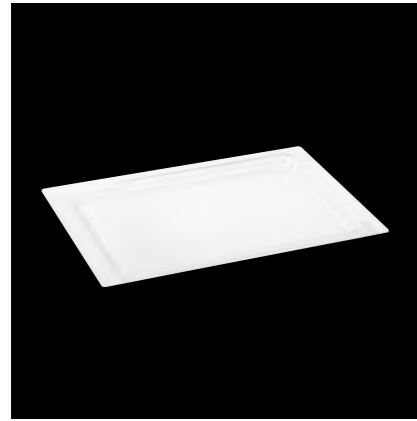

Pyrex glass tray for 60 cm ovens and blast chillers.

COD **GT 60**  
EAN 8019801014781



Stainless steel tray for 45 cm ovens and 60 cm steam ovens.

COD **XT 45**  
EAN 8019801014880



Tray (h30) for 60 cm steam oven

COD **FET 60 VAP**  
EAN 8019801032549



Stainless steel microperforated tray for 45 cm ovens. Suitable for steam cooking

COD **STEAM POT WITH COVER**  
EAN 8019801014927



Kit of Gastronorm stainless steel containers plus support rack

COD **GASTRO BOX 6 SET**  
EAN 8019801014903

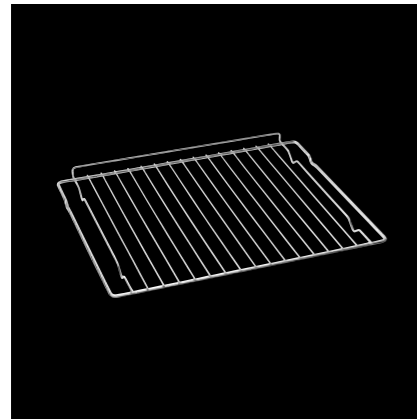

Flat rack for 60 cm ovens

COD **FG 60**  
EAN 8019801014767

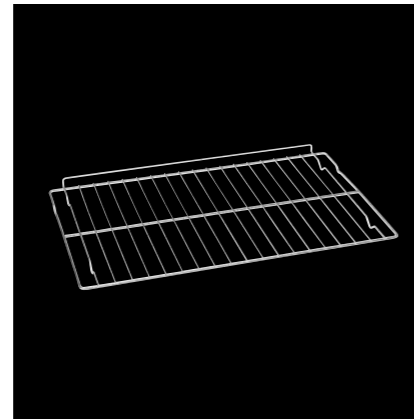

Flat rack for 75 cm and 90 x 48 ovens

COD **FG 90/75**  
EAN 8019801015774

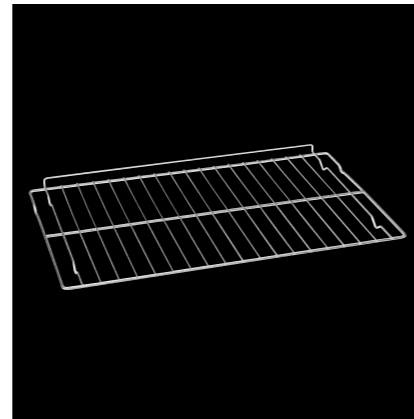

Flat rack for 90 x 60 ovens

COD **FG 96**  
EAN 8019801018093

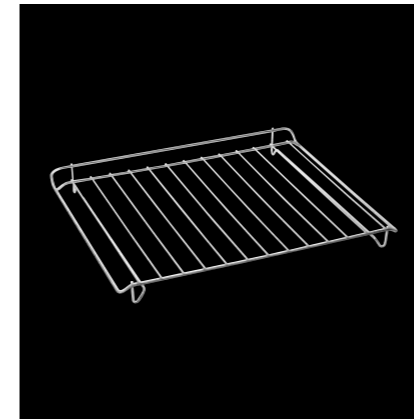

Flat rack for 45 cm ovens

COD **FG 45**  
EAN 8019801014873

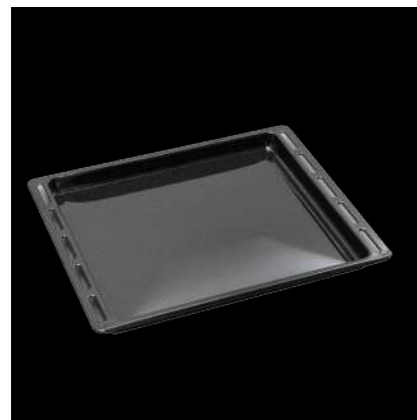

Enamelled tray (h30) for 60 cm ovens

COD **FET 60 BK**  
EAN 8019801025039

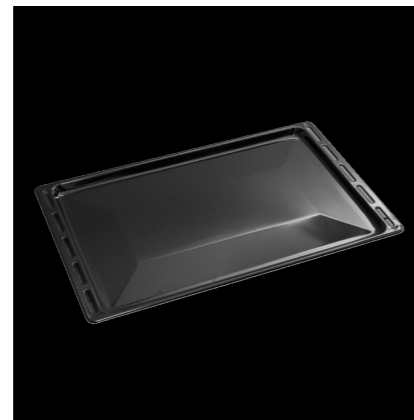

Enamelled tray (h15) for 75 cm ovens and 90 x 48 ovens

COD **FET 90/75 BK**  
EAN 8019801025046

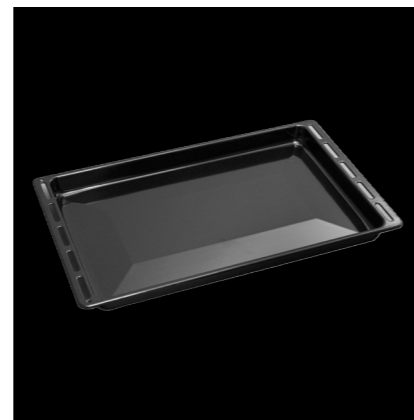

Deep enamelled tray (h40) for 75 cm and 90 x 48 ovens

COD **FETL 90/75 BK**  
EAN 8019801025053



Enamelled tray (h40) for 90 x 60 ovens

COD **FET 96 BK**  
EAN 8019801025060

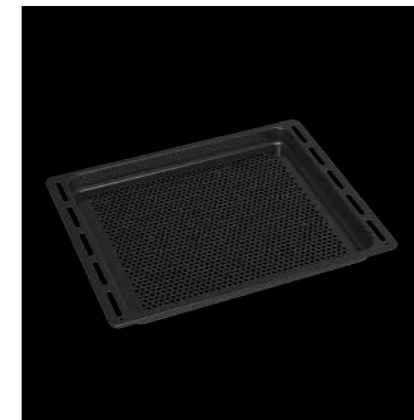

Enamelled AirFry tray (h30) x 60 ovens

COD **FET AIR BK**  
EAN 8019801032556



Wooden container for coffee accessories for inside drawer

COD **CM DC 150**  
EAN 8019801013494



Wooden container for wine accessories for inside drawer

COD **FWC ADC 150**  
EAN 8019801013487



Set of fully removable telescopic rails for 60/75/90 cm ovens

COD **TELG 60 M**  
EAN 8019801014750

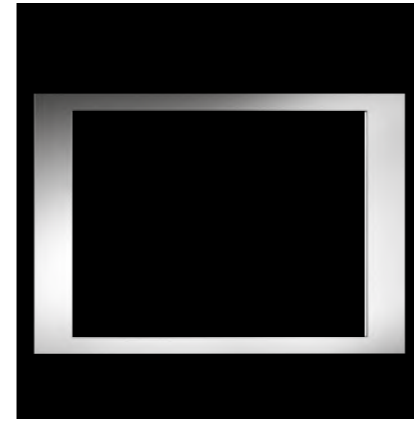

30" stainless steel trim kit

COD **FK 30" X**  
EAN 8019801014729



Professional Frame Kit

COD **F6PTK30BC**  
EAN 8019801026265



Stainless steel panel and handle for vacuum sealing drawer, model FVSD 2900

COD **FT 29 X**  
EAN 8019801019502



Metal pizza peel

COD **SHOW PIZZA**  
EAN 8019801014712

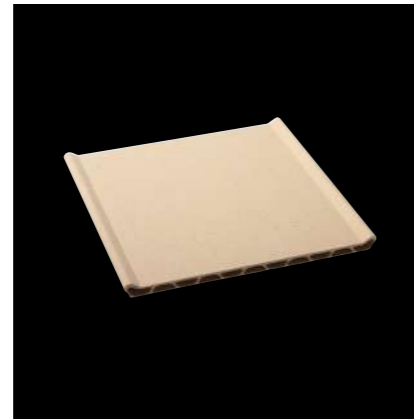

Pizza stone

COD **REFT PIZZA**  
EAN 8019801014699

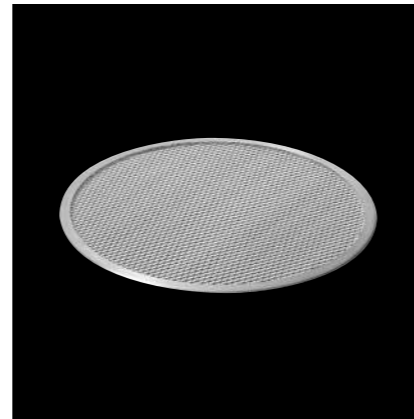

Steel round rack for pizza

COD **ROGR PIZZA**  
EAN 8019801014705

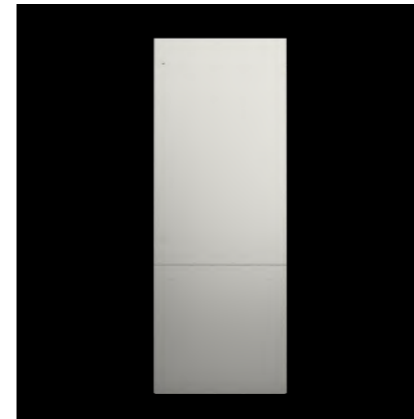

Stainless Steel Panels Kit for Refrigerator  
FBCD 761 TNF EDBL - FBCD 762 TNF EDBL

COD **F4PANEL30BMSS**  
EAN 8019801031825

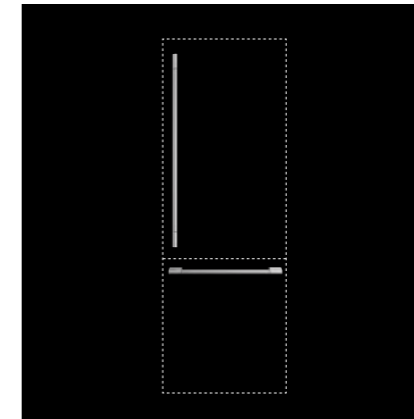

Pro stainless steel handles kit for refrigerators  
FBCD 761 TNF EDBL - FBCD 762 TNF EDBL

COD **F4HKPRO30BM**  
EAN 8019801031832

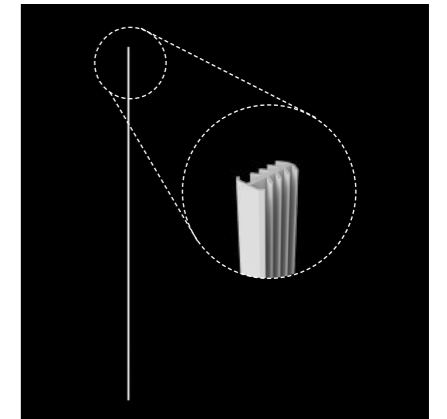

Fixing kit for refrigerator union  
FBCD 761 TNF EDBL - FBCD 762 TNF EDBL

COD **FM4JOINKIT**  
EAN 8019801032686

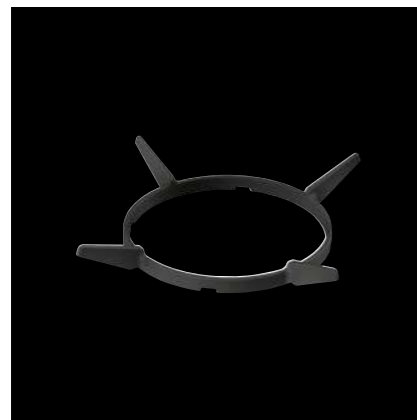

Cast iron wok adaptor

COD **CAST IRON WOK ADAPTOR**  
EAN 8019801014965

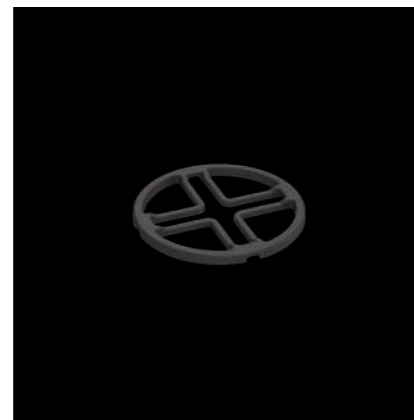

Cast iron small adaptor

COD **CAST IRON SMALL ADAPTOR**  
EAN 8019801014972



Scraper for cleaning glass-ceramic

COD **CERAMIC SCRAPER**  
EAN 8019801015016

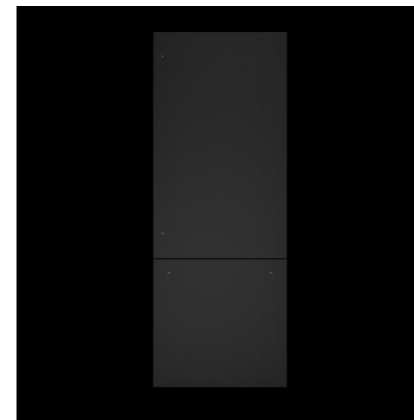

Black Panels Kit for Refrigerator  
FBCD 761 TNF EDBL - FBCD 762 TNF EDBL

COD **F4PANEL30BMUMBK**  
EAN 8019801032778

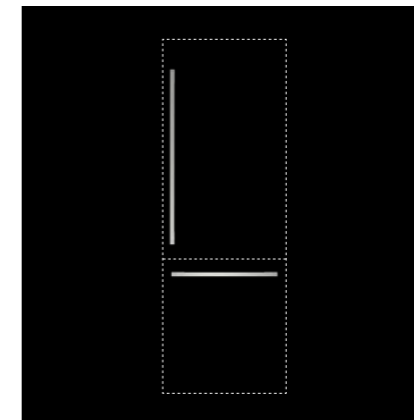

Urbantech stainless steel grab bars kit for refrigerators  
FBCD 761 TNF EDBL - FBCD 762 TNF EDBL

COD **F4HKU30BMSS**  
EAN 8019801032792

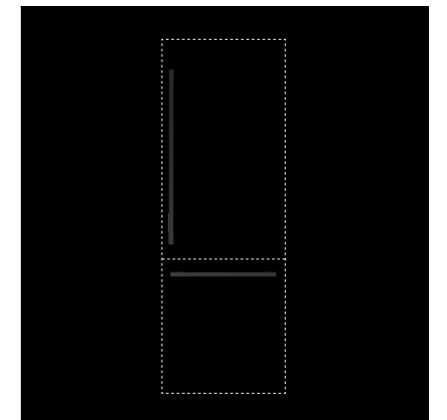

Urbantech black grab bars kit for refrigerators  
FBCD 761 TNF EDBL - FBCD 762 TNF EDBL

COD **F4HKU30BMMBK**  
EAN 8019801032785

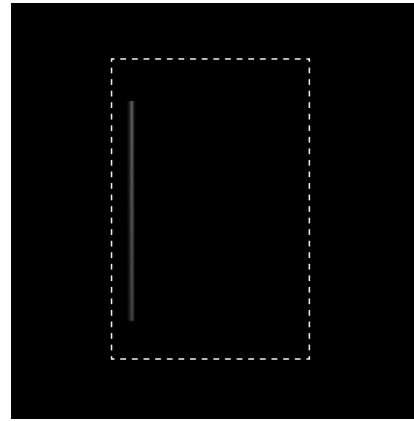

Black Professional handle kit for 88 and 82 cm wine cellars

COD **FMHKBITMBK**  
EAN 8019801033508

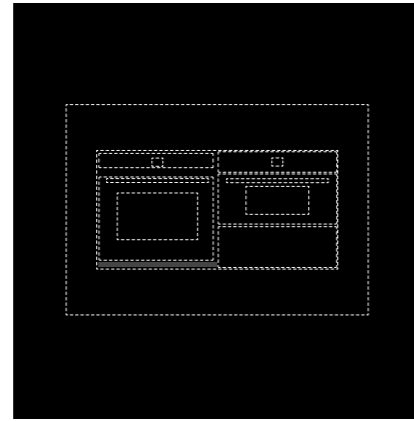

Black compensating profile kit for 30" Plano ovens

COD **COMKIT30BK**  
EAN 8019801034161

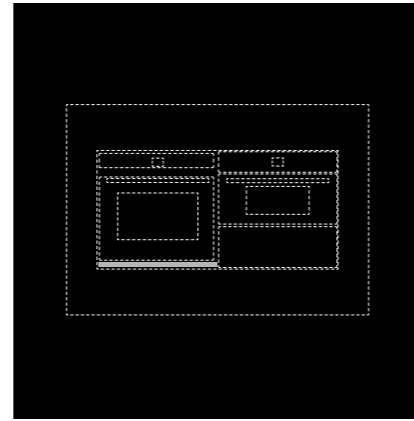

Black compensating profile kit for 30" Plano ovens

COD **COMKIT30X**  
EAN 8019801034154



S. Steel colander (L389 x W152 x H100)

COD **C 4319 X**  
EAN 8019801011414

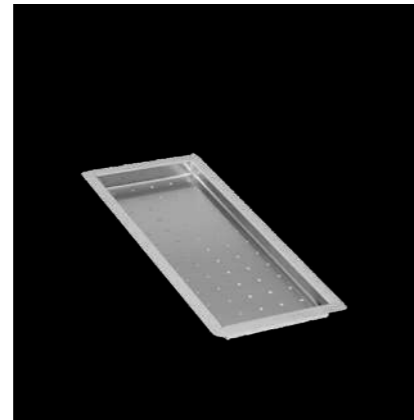

S. Steel perforated tray (L389 x W152 x H26)

COD **T 4319 X**  
EAN 8019801011421

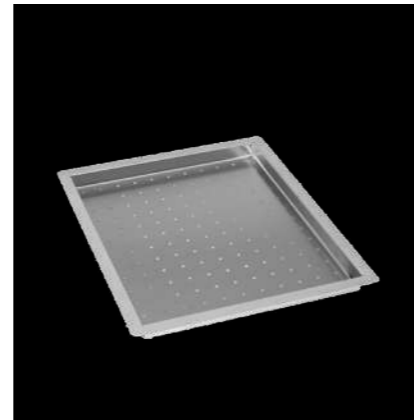

S. Steel perforated tray (L389 x W152 x H26)

COD **T 4336 X**  
EAN 8019801011438

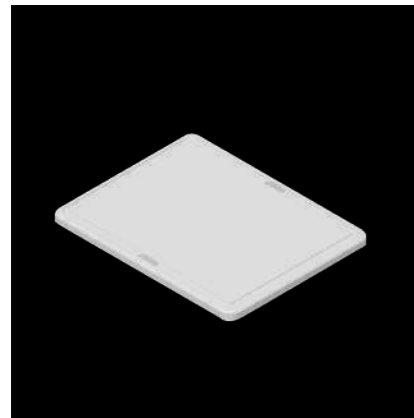

White polyethylene chopping board

COD **T 4233 PL**  
EAN 8019801011445



Automatic 2-way square drain plug

COD **QD 2 X**  
EAN 8019801011469

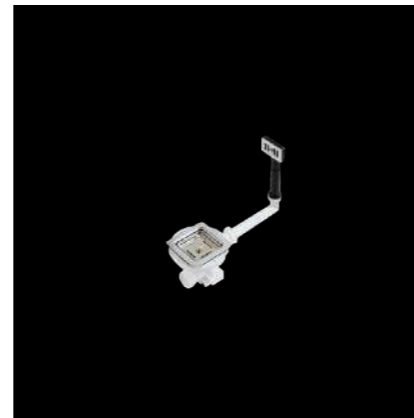

Automatic 1-way square drain plug

COD **QD 1 X**  
EAN 8019801011452

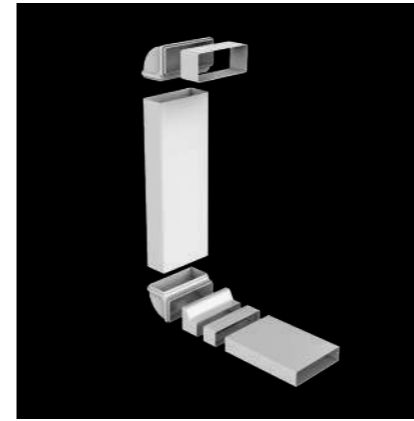

Duct kit and fittings for ARIA+ hob

COD **FDUCTKIT ARIA+/2**  
EAN 8019801036080

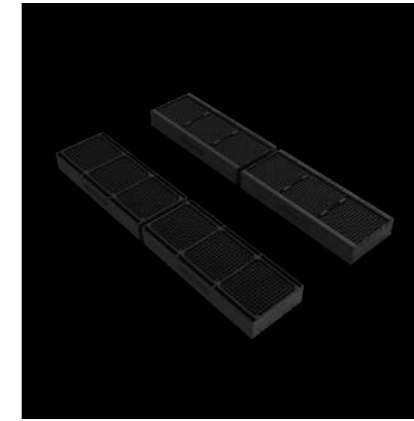

Carbon filter kit for ARIA+ extraction hob

COD **FCHF ARIA+**  
EAN 801980103274



Anti-grease filter kit for ARIA+ extraction hob

COD **FGREASE ARIA+**  
EAN 801980103275

Carbon filter kit - Mod. Hood FCHD 900 RC X e FCHD 1200 RC X

EAN 8019801024247

Carbon filter kit - Mod. Hood FBGHD 850 TC X

EAN 8019801024254

Carbon filter kit - Mod. Hood FDDH 900 TRC X

EAN 8019801024223

Carbon filter kit - Mod. Hood FDDH 1120 TRC X

EAN 8019801024230

Carbon filter kit - Mod. Hood FBGHD 800 PT X, FBHD 900 PT X, and FBHD 700 PT X

EAN 8019801024278

Carbon filter kit - Mod. Hood FCLHD 900 TC BK

EAN 8019801024179

Carbon filter kit - Mod. Hood FPRHD 482 TC X and FPRHD 482 TC MBK

EAN 8019801024162

Carbon filter kit - Mod. Hood FPRHD 362 TC X and FPRHD 362 TC MBK

EAN 8019801024155

Carbon filter kit - Mod. Hood FPHD 52 TS BK

EAN 8019801024216

Carbon filter kit - Mod. Hood FTIHD 1260 / 960 and FTHD 1200 / 900

EAN 8019801024261

Carbon filter kit - Mod. Hood FCLHD 8041 HID TS BK2

EAN 8019801029525

Carbon filter kit - Mod. Hood FCLHD 9041 HID TS BK2

EAN 8019801029532



Inner remote motor

COD **FEM 1**  
EAN 8019801023325



Outer remote motor

COD **FEM 2**  
EAN 8019801023332



On-Board motor

COD **FDD 2M**  
EAN 8019801023400

**FULGOR**  
MILANO

# TECHNICAL DATA

# PROFESSIONAL

SOFIA 48" INDUCTION RANGE WITH GRIDDLE



FSRC 4807 P MI MK 2F G...	
Type / Aesthetic	Induction / Stainless Steel
Finish	Stainless steel <b>X</b> Matte Black <b>MBK</b>
Interiors: enamel / other	Ultra Black Piro / -
<b>COOKING HOB</b>	
Supply	Induction
Surface	CeraBlack
Trilaminare Teppanyaki Plate	•
Pan Detector / Safety Lock	• / •
Cooling with Fans	•
Power Levels	1 - 9
	Fusion function 45°C / Slow cooking at 70°C
	Error code indicator
	Booster for each zone
	Residual heat release H
	Automatic Heat Up
	Minute Minder
<b>COOKING ZONES FEATURES</b>	
Front left power (L9 - Booster) (W)	Ø 230 mm 2300 - 3700 W
Rear left power (L9 - Booster) (W)	Ø 200 mm 1850 - 3000 W
Dual Max power (L9 - Booster) (W)	Ø 280 mm 3000 - 5500 W
Center power (L9 - Booster) (W)	Ø 200 mm 1850 - 2600 W
Front right power (L9 - Booster) (W)	Ø 230 mm 2300 - 3700 W
Rear right power (L9 - Booster) (W)	Ø 200 mm 1850 - 3000 W
Bridge front and rear left (L9 - Booster) (W)	2x Ø 200 mm 2x 850 - 3000 W
<b>OVEN</b>	
Type / Functions no.	Electronic Multifunction / 18
Type of ventilation	Main oven Dual ventilation - Secondary oven Thermoventilated
Energy efficiency class	A
Capacity (liters)	125 + 65 L
Forced cooling	•
<b>PERFORMANCE</b>	
Max cooking temperature	290° C
Pyrolysis temperature (Self-cleaning)	460° C
Pizza Pizzeria 350° function / AirFry	• / •
<b>CONTROLS</b>	
Control system / Recipes	Creactive with knobs / •
Automatic power off / Booster	• / •
Meat Probe	Main oven
<b>SAFETY</b>	
Door lock (during pyrolysis)	•
Cool-touch door / no. of glass panes	• / 4
Soft-close door	•
<b>ACCESSORIES</b>	
Lighting (Halogen, 25 W) no.	3 + 2
Flat racks / Telescopic rack no.	2 + 2 / 1 + 1
Trays no. / type	1 / Enamelled tray
Enamelled AirFry tray	1
Stainless steel AirFry tray	1
Round rack / Pizza shovel	1 / •
Firestone for pizza no.	1
<b>POWER RATING</b>	
Max electrical power (W)	21400 W
Voltage / Frequency (V - Hz)	220 - 240 V / 380 - 415V 2 N ~ ; 50 - 60 Hz
<b>DIMENSIONS</b>	
Width mm	1216
Height (min - Max) mm	898 - 947
Depth mm	698

# PROFESSIONAL

SOFIA INDUCTION 48"



FSRC 4807 P MI MK 2F...	
Type / Aesthetic	Induction / Stainless Steel
Finish	Stainless steel <b>X</b> Matte Black <b>MBK</b>
Interiors: enamel / other	Ultra Black Piro / -
<b>COOKING HOB</b>	
Supply	Induction
Surface	CeraBlack
Pan Detector / Safety Lock	• / •
Cooling with Fans	•
Power Levels	1 - 9
	Fusion function 45°C / Slow cooking at 70°C
	Error code indicator
	Booster for each zone
	Residual heat release H
	Automatic Heat Up
	Minute Minder
<b>COOKING ZONES FEATURES</b>	
Front left power (L9 - Booster) (W)	Ø 230 mm 2300 - 3700 W
Rear left power (L9 - Booster) (W)	Ø 200 mm 1850 - 3000 W
Dual Max power (L9 - Booster) (W)	Ø 280 mm 3000 - 5500 W
Center power (L9 - Booster) (W)	Ø 200 mm 1850 - 2600 W
Front right power (L9 - Booster) (W)	Ø 230 mm 2300 - 3700 W
Rear right power (L9 - Booster) (W)	Ø 200 mm 1850 - 3000 W
Bridge front and rear left (L9 - Booster) (W)	2x Ø 200 mm 2x 850 - 3000 W
<b>OVEN</b>	
Type / Functions no.	Electronic Multifunction / 18
Type of ventilation	Main oven Dual ventilation - Secondary oven Thermoventilated
Energy efficiency class	A
Capacity (liters)	125 + 65 L
Forced cooling	•
<b>PERFORMANCE</b>	
Max cooking temperature	290° C
Pyrolysis temperature (Self-cleaning)	460° C
Pizza Pizzeria 350° function / AirFry	• / •
<b>CONTROLS</b>	
Control system / Recipes	Creactive with knobs / •
Automatic power off / Booster	• / •
Meat Probe	Main oven
<b>SAFETY</b>	
Door lock (during pyrolysis)	•
Cool-touch door / no. of glass panes	• / 4
Soft-close door	•
<b>ACCESSORIES</b>	
Lighting (Halogen, 25 W) no.	3 + 2
Flat racks / Telescopic rack no.	2 + 2 / 1 + 1
Trays no. / type	1 / Enamelled tray
Enamelled AirFry tray	1
Stainless steel AirFry tray	1
Round rack / Pizza shovel	1 / •
Firestone for pizza no.	1
<b>POWER RATING</b>	
Max electrical power (W)	21400 W
Voltage / Frequency (V - Hz)	220 - 240 V / 380 - 415V 2 N ~ ; 50 - 60 Hz
<b>DIMENSIONS</b>	
Width mm	1216
Height (Min - Max) mm	898 - 947
Depth mm	698

# PROFESSIONAL

FREE-STANDING KITCHENS



	FSRC 9005 P MI MK 2F ...		FSRC 3605 P MI MK 2F ...		FSRC 3004 P MI MK 2F ...	
Type	90 cm free-standing kitchen		36" free-standing kitchen		30" free-standing kitchen	
Finish	Stainless steel Matte Black	<b>X</b> <b>MBK</b>	Stainless steel Matte Black	<b>X</b> <b>MBK</b>	Stainless steel Matte Black	<b>X</b> <b>MBK</b>
Interiors: enamelled / other	Ultra Black Piro / -		Ultra Black Piro / -		Ultra Black Piro / -	
<b>COOKING HOB</b>						
Supply	Induction		Induction		Induction	
Surface	CeraBlack		CeraBlack		CeraBlack	
Pan detection sensor / Safety switch	• / •		• / •		• / •	
Fan cooling	•		•		•	
power levels	1 / 9		1 / 9		1 / 9	
	45 °C melting function	Slow cooking at 70 ° C	45 °C melting function	Slow cooking at 70 ° C	45 °C melting function	Slow cooking at 70 ° C
	Booster for each zone	Residual heat detector (H)	Booster for each zone	Residual heat detector (H)	Booster for each zone	Residual heat detector (H)
	Automatic Heat Up	Minute Minder	Automatic Heat Up	Minute Minder	Automatic Heat Up	Error code indicator
	Error code indicator		Error code indicator			
<b>COOKING ZONE FEATURES</b>						
Left front power (min - Max) (W)	Ø 230 mm 2300 - 3700 W		Ø 230 mm 2300 - 3700 W		Ø 230 mm 2300 - 3700 W	
Rear left power (min - Max) (W)	Ø 200 mm 1850 - 3000 W		Ø 200 mm 1850 - 3000 W		Ø 165 mm 1400 - 2200 W	
DualMaxPower (min - Max) (W)	Ø 280 mm 3000 - 5500 W		Ø 280 mm 3000 - 5500 W		-	
Central power (min - Max) (W)	Ø 200 mm 1850 - 2600 W		Ø 200 mm 1850 - 2600 W		-	
Right front power (min - Max) (W)	Ø 230 mm 2300 - 3700 W		Ø 230 mm 2300 - 3700 W		Ø 200 mm 1850 - 3000 W	
Rear right power (min - Max) (W)	Ø 200 mm 1850 - 3000 W		Ø 200 mm 1850 - 3000 W		Ø 200 mm 1850 - 3000 W	
<b>OVEN FEATURES</b>						
Type / Functions no.	Electronic multifunction / 18		Electronic multifunction / 18		Electronic multifunction / 18	
Interior dual convection	•		•		•	
Efficiency class	A		A		A	
Capacity (litres)	150 L		150 L		125 L	
Forced cooling	•		•		•	
<b>PERFORMANCE</b>						
Max cooking temperature			290° C		290° C	
Pyrolysis temperature / Self-cleaning			460° C / •		460° C / •	
Thermoventilated / Recipes	• / •		• / •		• / •	
Pizza Pizzeria 350° function / AirFry	• / •		• / •		• / •	
<b>CONTROLS</b>						
Control system	Creative with knobs		Creative with knobs		Creative with knobs	
Automatic power off	•		•		•	
Booster / Meat Probe	• / •		• / •		• / •	
<b>SAFETY</b>						
Door lock (during pyrolysis)	•		•		•	
Cool-touch door / no. of glass panes / Soft closing	• / 4 / •		• / 4 / •		• / 4 / •	
<b>ACCESSORIES</b>						
Lighting (Halogen, 25 W) no.	3		3		3	
Flat / Telescopic racks no.	2 / 1		2 / 1		2 / 1	
Trays no. / type	1 / enamelled tray		1 / enamelled tray		1 / enamelled tray	
AirFry tray / Pizza set no.	1 / 1		1 / 1		1 / 1	
<b>POWER RATING</b>						
Max electrical power (W)	14400 W		14400 W		10800 W	
Voltage / Frequency (V - Hz)	380 - 415 V ~ 3 N ; 50 - 60 Hz		3 380 - 415 V ~ 3 N ; 50 - 60 Hz		220 - 240 V ~ / 380 - 415 V ~ 3N; 50-60 Hz	
<b>DIMENSIONS</b>						
Width (mm)	898		910		756	
Height (min - max) mm	898 - 947		898 - 947		898 - 947	
Depth (mm)	691		691		691	

# PROFESSIONAL

48" FREE-STANDING KITCHEN



	FSRC 4807 2P MK 2F ...	
Type	48" free-standing kitchen	
Finish	Stainless steel Matte Black	<b>X</b> <b>MBK</b>
Interiors: enamelled / other	Ultra Black Piro / -	
<b>COOKING HOB</b>		
Supply	Gas	
Tubular griddle burner	1 x 1200 - 3350 W	
Crescendo burner power (Min-Max)	2 x 450 - 4500 W / 4 x 450 - 4000 W	
Gas safety	•	
Cast iron grates / griddle no.	3 / 1	
Hob surface	Matte black enamelled	
<b>OVENS</b>		
Type	Electronic multifunction	
Dual convection / Thermoventilated	Primary / Secondary	
Efficiency class	A	
Capacity (litres)	125 + 65 L	
Forced cooling	•	
Functions no.	18	
<b>PERFORMANCE</b>		
Max cooking temperature	290° C	
Pyrolysis temperature / Self-cleaning	460° C / •	
Pizza Pizzeria 350° function	•	
AirFry (oven-frying)	•	
<b>CONTROLS</b>		
Control system	Creative with knobs	
Recipes	•	
Automatic power off	•	
Booster	•	
Meat probe	Primary oven	
<b>SAFETY</b>		
Door lock (during pyrolysis)	•	
Cool-touch door / no. of glass panes	• / 4	
Soft-close door	•	
<b>ACCESSORIES</b>		
Lighting (Halogen, 25 W) no.	3 + 2	
Flat racks no.	2 + 2	
Telescopic rack no.	1 + 1	
Trays no. / type	1 / enamelled tray	
Enamelled AirFry tray	1	
Stainless steel AirFry tray	1	
Round rack / Pizza shovel	1 / •	
Firestone for pizza no.	1	
<b>POWER RATING / GAS</b>		
Max electrical power (W)	7000 W	
Voltage / Frequency (V - Hz)	220 - 240 V / 380 - 415V 2 N ~; 50 - 60 Hz	
Gas types	NG - LPG	
Cord / Plug	- / -	
<b>DIMENSIONS</b>		
Width (mm)	1216	
Height (min - max) mm	898 - 947	
Depth (mm)	691	

# PROFESSIONAL

36" FREE-STANDING KITCHENS



	FSRC 3606 P MG MK 2F ...	FSRC 3606 GG ED 2F ...
Type	36" free-standing kitchen	36" free-standing kitchen
Finish	Stainless steel Matte Black	Stainless steel Matte Black
Interiors: enamelled / other	Ultra Black Piro / -	Ultra Black Piro / -
<b>COOKING HOB</b>		
Supply	Gas	Gas
Crescendo Dual Burners	6	6
Gas power (min-max)	450 - 4500 W	450 - 4500 W
Gas safety	•	•
Cast iron grates no.	3	3
Hob surface	Matte black enamelled	Matte black enamelled
<b>OVENS</b>		
Type	Electronic multifunction	Gas
Interior dual convection	•	•
Efficiency class	A	A
Capacity (litres)	150 L	150 L
Forced cooling	•	•
Functions no.	18	3
<b>PERFORMANCE</b>		
Max cooking temperature	290° C	300° C
Pyrolysis temperature	460° C	-
Self-cleaning	•	-
Pizza Pizzeria 350° function	•	-
AirFry (oven-frying)	•	-
<b>CONTROLS</b>		
Control system	Creactive with knobs	Digital display with knobs
Recipes	•	-
Automatic power off	•	-
Booster	•	-
Meat probe	•	-
<b>SAFETY</b>		
Door lock (during pyrolysis)	•	-
Cool-touch door / no. of glass panes	• / 4	• / 4
Soft-close door	•	•
<b>ACCESSORIES</b>		
Lighting (Halogen, 25 W) no.	3	3
Flat racks no.	2	2
Telescopic rack no.	1	1
Trays no. / type	1 / enamelled tray	1 / enamelled tray
AirFry tray no.	1	-
Pizza set no.	1	-
<b>POWER RATING / GAS</b>		
Max electrical power (W)	3650 W	200 W
Voltage / Frequency (V - Hz)	220-240 V~ 50-60 Hz	220-240 V~ 50-60 Hz
Gas types	NG - LPG	NG - LPG
Power cord	-	•
Plug	-	Schuko
<b>DIMENSIONS</b>		
Width (mm)	910	910
Height (min - max) mm	898 - 947	898 - 947
Depth (mm)	691	691

# PROFESSIONAL

30" PIRO COLUMN OVEN



	FSO 300 P MK 2F X
Type	30" oven
Finish	Stainless steel
Interiors: enamelled / other	Ultra Black Piro / -
<b>FEATURES</b>	
Type	Electronic multifunction
Interior dual convection	•
Efficiency class	A
Capacity (litres)	125 L
Forced cooling	•
Functions no.	18
<b>PERFORMANCE</b>	
Max cooking temperature	290° C
Pyrolysis temperature	460° C
Thermoventilated / Recipes	• / •
Pyrolytic	•
Pizza Pizzeria 350° function	•
AirFry (oven-frying)	•
<b>CONTROLS</b>	
Control system	Creactive with knobs
Auto power off	•
Meat probe	•
Booster	•
<b>SAFETY</b>	
Door lock (during pyrolysis)	•
Cool-touch door / no. of glass panes / Soft closing	• / 4 / •
<b>ACCESSORIES</b>	
Lighting (Halogen 25 W)	3
Flat / Telescopic racks no.	2 / 1
Trays no. / type	1 / enamelled tray
AirFry tray no.	1
Pizza set no.	1
<b>POWER RATING</b>	
Max oven electrical power (W)	3650 W
Voltage / Frequency (V - Hz)	220 - 240 V; 50 - 60 Hz
Power cord	•
<b>DIMENSIONS</b>	
Width (mm)	758
Height (mm)	707
Depth (mm)	640
Built-In Cut Out (W x H x D) mm	722 x 696 x 610

# PROFESSIONAL

30" OVENS



	FPCSO 300 TEM X	FPCMO 300 TEM X
Type	Combined Steam	Combined Microwave
Finish	Stainless Steel	Stainless Steel
Temperature regulation	Electronic	Electronic
<b>FUNCTIONS</b>		
AirFry (oven-frying)	•	•
Microwave / Steam cooking	- / •	• / -
Steam heating	•	-
Microwave / steam convection oven	- / •	• / -
Steam cleaning / circuit	• / •	-
Puff	•	-
Convection bake	•	•
Convection and Grill cooking	•	•
Convection grilling	•	•
Grilling	•	•
Microwave and Grill cooking	-	•
Eco Convection bake	•	-
Oven lights	•	•
<b>CONTROL PANEL</b>		
Control type	Creactive Extended	Creactive Extended
Display	TFT 3.5"	TFT 3.5"
Recipe menu	•	•
Controls / Languages	Double Full Touch Display / 15	Double Full Touch Display / 15
<b>FEATURES</b>		
Manual quick pre-heating	-	-
Meat probe	•	-
12/24 clock format	•	•
°C / °F	•	•
<b>OVEN DOOR</b>		
Cool-touch door	•	•
<b>OVEN CAPACITY</b>		
Gross capacity (litres)	34 L	34 L
Interiors:	Stainless steel	Stainless steel
Rack position	3	3
Lighting (Halogen, 25 W) no.	1	1
Upper heating element for grilling	1500 W	1500 W (230 V)
Steam generator /Microwave power	800 W	900 W
Lower heating element power	300 W	-
Convection element power	1500 W	1500 W (230 V)
<b>ACCESSORIES</b>		
Removable Water Tank	•	-
S.Steel Gastronorm Tray	1 / Stainless steel	1 / Stainless steel
Standard Flat Grill Rack / removable no.	1 / 1	1 / -
S.Steel Perforated Tray with Lid	•	-
Glass turntable plate	-	•
Round Grill Rack	-	•
<b>POWER RATING</b>		
Max oven electrical power (W)	3200 W	3200 W
Voltage / Frequency (V - Hz)	220 - 240 V ~; 50 Hz	220 - 240 V ~; 50 Hz
Cord / Plug	• / Schuko	• / Schuko
<b>DIMENSIONS</b>		
Width (mm)	758	758
Height (mm)	474	474
Depth (mm)	591	591
Built-In Cut Out (W x H x D) mm	722 x 463 x 560	722 x 463 x 560

# PROFESSIONAL

WARMING DRAWER



	FPWD 3024 X
Type	30" Built-In drawer
Front finish	Stainless steel
Interiors	Anti-slip rubber bottom
Handle / Soft closing opening	• / •
<b>PERFORMANCE</b>	
Max cooking temperature	85° C
Slow cooking / Leavening	• / •
Reheating cooked food and dishes	•
<b>CONTROLS</b>	
On/off key	•
Thermostat / Ventilation	• / •
Internal light	•
<b>SAFETY</b>	
Dark front panel	•
<b>POWER RATING</b>	
Max electrical power (W)	1100 W
Voltage / Frequency (V - Hz)	220 - 240 V; 50 - 60 Hz
Cord / Plug	• / •
<b>DIMENSIONS</b>	
Width (mm)	758
Height (mm)	264
Depth (mm)	632
Built-In Cut Out (W x H x D) mm	722 x 235 x 610

NEW

## PROFESSIONAL

48" INDUCTION RANGE TOP



FSRT 4807 ID X	
Type	48" Induction Range Top
Aesthetic	Stainless Steel
<b>COOKING HOB</b>	
Supply	Induction
Surface	CeraBlack
Pan Detector / Safety Lock	• / •
Cooling with Fans	•
Powe Levels	1 - 9
	Fusion function 45°C
	Slow cooking at 70° C
	Booster for each zone
	Residual heat release H
	Automatic Heat Up
	Minute Minder
	Error code indicator
<b>COOKING ZONES FEATURES</b>	
Front left power (L9 - Booster) (W)	Ø 230 mm 2300 - 3700 W
Rear left power (L9 - Booster) (W)	Ø 200 mm 1850 - 3000 W
Dual Max power (L9 - Booster) (W)	Ø 280 mm 3000 - 5500 W
Center power (L9 - Booster) (W)	Ø 200 mm 1850 - 2600 W
Front right power (L9 - Booster) (W)	Ø 230 mm 2300 - 3700 W
Rear right power (L9 - Booster) (W)	Ø 200 mm 1850 - 3000 W
Bridge front and rear left (L9 - Booster) (W)	2x Ø 200 mm 2x 1850 - 3000 W
<b>POWER RATING</b>	
Max electrical power (W)	14400 W
Voltage / Frequency (V - Hz)	220 - 240 V / 380 - 415 V 3N ; 50 - 60 Hz
Cord	•
<b>DIMENSIONS</b>	
Width mm	1216
Height (Min - Max) mm	179
Depth mm	698
Built-in cut out (LxAxP) mm	1222 x 179 x 610 - 650

NEW

## PROFESSIONAL

36" INDUCTION RANGE TOP



FSRT 3605 ID X	
Type	36" Induction Range Top
Aesthetic	Stainless Steel
<b>COOKING HOB</b>	
Supply	Induction
Surface	CeraBlack
Pan Detector / Safety Lock	• / •
Cooling with Fans	•
Powe Levels	1 - 9
	Fusion function 45°C
	Slow cooking at 70° C
	Booster for each zone
	Residual heat release H
	Automatic Heat Up
	Minute Minder
	Error code indicator
<b>COOKING ZONES FEATURES</b>	
Front left power (L9 - Booster) (W)	Ø 230 mm 2300 - 3700 W
Rear left power (L9 - Booster) (W)	Ø 200 mm 1850 - 3000 W
Dual Max power (L9 - Booster) (W)	Ø 280 mm 3000 - 5500 W
Center power (L9 - Booster) (W)	Ø 200 mm 1850 - 2600 W
Front right power (L9 - Booster) (W)	Ø 230 mm 2300 - 3700 W
Rear right power (L9 - Booster) (W)	Ø 200 mm 1850 - 3000 W
<b>POWER RATING</b>	
Max electrical power (W)	10800 W
Voltage / Frequency (V - Hz)	220 - 240 V / 380 - 415 V 3N ; 50 - 60 Hz
Cord	•
<b>DIMENSIONS</b>	
Width mm	910
Height (min - Max) mm	179
Depth mm	698
Built-in cut out (LxAxP) mm	914 x 179 x 610 - 650

NEW

## PROFESSIONAL

30" INDUCTION RANGE TOP



FSRT 3004 ID X	
Type	30" Induction Range Top
Aesthetic	Stainless Steel
<b>COOKING HOB</b>	
Supply	Induction
Surface	CeraBlack
Pan Detector / Safety Lock	• / •
Cooling with Fans	•
Power Levels	1 - 9
	Fusion function 45°C
	Slow cooking at 70° C
	Booster for each zone
	Residual heat release H
	Automatic Heat Up
	Minute Minder
	Error code indicator
<b>COOKING ZONES FEATURES</b>	
Front left power (L9 - Booster) (W)	Ø 230 mm 2300 - 3700 W
Rear left power (L9 - Booster) (W)	Ø 165 mm 1400 - 2200 W
Front right power (L9 - Booster) (W)	Ø 200 mm 1850 - 3000 W
Rear right power (L9 - Booster) (W)	Ø 200 mm 1850 - 3000 W
<b>POWER RATING</b>	
Max electrical power (W)	7200 W
Voltage / Frequency (V - Hz)	220 - 240 V / 380 - 415 V 3N ; 50 - 60 Hz
Cord	•
<b>DIMENSIONS</b>	
Width mm	756
Height (Min - Max) mm	179
Depth mm	698
Built-in cut out (LxAxP) mm	762 x 179 x 610 - 650

## PROFESSIONAL

48" GAS RANGE TOP



FSRT 4807 G X	
Type	48" Gas Range Top
Finish	Stainless Steel
<b>FEATURES</b>	
Supply	Gas
Crescendo Dual Burners	1 x 1200 - 3350 W
Gas power (Min-Max)	6 x 450 - 4500 W
Gas safety	•
Cast iron grates / Cast iron plate n.	3 / 1
Hob surface	Matte black enamelled
<b>CONTROLS</b>	
Steel knobs	•
<b>ACCESSORIES ON REQUEST</b>	
Wok adapter / cast iron heat diffuser	• / •
<b>ELECTRICAL / GAS FEATURES</b>	
Max electrical power (W)	0.6 W
Voltage / Frequency (V - Hz)	220 - 240 V ~ ; 50 - 60 Hz
Gas types	NG - LPG
Power cord	•
Plug	Schuko
<b>DIMENSIONS</b>	
Width mm	1216
Height mm	179
Depth mm	698
Built-In Cut Out (W x H x D) mm	1222 x 179 x 610 - 650

# PROFESSIONAL

36" SLOT-IN GAS COOKTOP



FSRT 3606 G X	
Type	36" Gas Range Top
Finish	Stainless steel
<b>FEATURES</b>	
Supply	Gas
Crescendo Dual Burners	6
Gas power (min-max)	450 - 4500 W
Gas safety	•
Cast iron racks no.	3
Hob surface	Matte black enamelled
<b>CONTROLS</b>	
Steel knobs	•
<b>ACCESSORIES ON REQUEST</b>	
Wok adapter / cast iron heat diffuser	• / •
<b>ELECTRICAL / GAS FEATURES</b>	
Max electrical power (W)	0.6 W
Voltage / Frequency (V - Hz)	220 - 240 V ~; 50 - 60 Hz
Gas types	NG - LPG
Power cord	•
Plug	Schuko
<b>DIMENSIONS</b>	
Width (mm)	910
Height (mm)	179
Depth (mm)	689
Built-In Cut Out (W x H x D) mm	914 x 179 x 610-650

# PROFESSIONAL

WALL-MOUNTED HOODS



	FPRHD 482 TC ...	FPRHD 362 TC ...
Type	48" wall-mounted hood	36" wall-mounted hood
Finish	Stainless steel Matte Black	Stainless steel Matte Black
	<b>X</b> <b>MBK</b>	<b>X</b> <b>MBK</b>
<b>FEATURES</b>		
Efficiency class	A	A
Extraction levels	4	4
Power off timer	•	•
Anti-grease filter saturation indicator	•	•
Type / no. of anti-grease filters	Stainless steel professional / 3	Stainless steel professional / 2
HP filter replacement light	•	•
Type and no. of lights	2 LED bars	2 LED bars
Dishwasher-safe filters	•	•
Ø Air outlet	Ø 200	Ø 200
Airflow non-return valve	•	•
<b>CONTROLS</b>		
Soft Touch control	•	•
<b>POWER RATING</b>		
Extraction power m³/h (max)	1450 m³/h	1450 m³/h
Noise (dBA)	48 - 75	48 - 75
Annual consumption (kWh)	195	195
Motor power (W)	550 W	550 W
Rated power (W)	320 W	320 W
Voltage / Frequency (V - Hz)	220 - 240 / 50 - 60	220 - 240 / 50 - 60
Power cord (m)	2	2
Plug (Schuko)	•	•
<b>ACCESSORIES ON REQUEST</b>		
48" chimney extension kit (on request)	Stainless steel: FPRHD 482 KIT X Matte Black: FPRHD 482 KIT MBK	Stainless steel: FPRHD 362 KIT X Matte Black: FPRHD 362 KIT MBK
HP filter for filtering version	FCHF 22 (X2)	FCHF 23 (X2)
<b>DIMENSIONS</b>		
Width (mm)	1219	914
Height (min - max) mm	779 - 1067	779 - 1067
Depth (mm)	609	609

# BBQ

BARBECUE GAS 1000

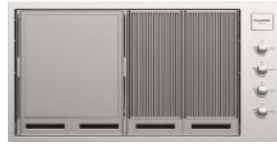

	FOBQ 1000 G X	FOBQ HL 1000 X	FOBQ LL 1000 X
Type	Built-In Barbecue	High lid	Low lid
Finish	Stainless steel	Stainless steel	Stainless steel
<b>FEATURES</b>			
Knob material / no.	Steel / 4	-	-
Teppanyaki (material)	Stainless steel	-	-
Grates (material)	Stainless steel	-	-
Tubular burners	4	-	-
Inner tub	Black enamel	-	-
Steel knob	-	•	•
Supply	Gas	-	-
Grates no.	2	-	-
Gastronorm liquid-collection tray	•	-	-
Heating grid	-	•	-
Total gas burner power	15.2 kW	-	-
Electronic ignition	•	-	-
Battery ignition	•	-	-
Thermometer / gas types	- / NG - LPG	• / -	- / -
<b>DIMENSIONS</b>			
Cooking zone width (mm)	900	-	-
Width (mm)	1046 x 189 x 540	920 x 191 x 600	920 x 54 x 559
Built-In Cut Out (W x H x D) mm	1025 x 210 x 505	-	-

# BBQ

BARBECUE GAS 1000



	FOBQ 1000 G MBK	FOBQ HL 1000 MBK	FOBQ LL 1000 MBK
Type	Built-In Barbecue	High lid	Low lid
Finish	Matte Black	Matte Black	Matte Black
<b>FEATURES</b>			
Knob material / no.	Steel / 4	-	-
Teppanyaki (material)	Cast-iron	-	-
Grates (material) / Tubular burners	Cast-iron / 4	- / -	- / -
Inner tub	Black enamel	-	-
Steel knob	-	•	•
Supply	Gas	-	-
Grates no.	2	-	-
Gastronorm liquid-collection tray	•	-	-
Heating grid	-	•	-
Total gas burner power	15.2 kW	-	-
Electronic ignition	•	-	-
Battery ignition	•	-	-
Thermometer	-	•	-
Gas types	NG - LPG	-	-
<b>DIMENSIONS</b>			
Cooking zone width (mm)	900	-	-
Width (mm)	1046 x 189 x 540	920 x 191 x 600	920 x 54 x 559
Built-In Cut Out (W x H x D) mm	1025 x 210 x 505	-	-

## BBQ

BARBECUE GAS 800



	FOBQ 803 G X	FOBQ HL 800 X	FOBQ LL 800 X
Type	Built-In Barbecue	High lid	Low lid
Finish	Stainless steel	Stainless steel	Stainless steel
<b>FEATURES</b>			
Knob material / no.	Steel / 3	-	-
Grates (material)	Stainless steel	-	-
Tubular burners	3	-	-
Inner tub	Black enamel	-	-
Steel knob	-	•	•
Supply	Gas	-	-
Grates no.	3	-	-
Gastronorm liquid-collection tray	•	-	-
Heating grid	-	•	-
Total gas burner power	11.4 kW	-	-
Electronic ignition	•	-	-
Battery ignition	•	-	-
Thermometer	-	•	-
Gas types	NG - LPG	-	-
<b>DIMENSIONS</b>			
Cooking zone width (mm)	650	-	-
Product (W x H x D) mm	830 x 189 x 540	705 x 191 x 600	705 x 54 x 559
Built-In Cut Out (W x H x D) mm	800 x 210 x 505	-	-

## BBQ

BARBECUE GAS 800



	FOBQ 803 G MBK	FOBQ HL 800 MBK	FOBQ LL 800 MBK
Type	Built-In Barbecue	High lid	Low lid
Finish	Matte Black	Matte Black	Matte Black
<b>FEATURES</b>			
Knob material / no.	Steel / 3	-	-
Grates (material)	Cast-iron	-	-
Tubular burners	3	-	-
Inner tub	Black enamel	-	-
Steel knob	-	•	•
Supply	Gas	-	-
Grates no.	3	-	-
Gastronorm liquid-collection tray	•	-	-
Heating grid	-	•	-
Total gas burner power	11.4 kW	-	-
Electronic ignition	•	-	-
Battery ignition	•	-	-
Thermometer	-	•	-
Gas types	NG - LPG	-	-
<b>DIMENSIONS</b>			
Cooking zone width (mm)	650	-	-
Width (mm)	830 x 189 x 540	705 x 191 x 600	705 x 54 x 559
Built-In Cut Out (W x H x D) mm	800 x 210 x 505	-	-

## BBQ

BARBECUE GAS 600



	FOBQ 602 G X	FOBQ 601 TY G X	FOBQ HL 600 X	FOBQ LL 600 X
Type	Built-In Barbecue	Built-in Teppanyaki	High lid	Low lid
Finish	Stainless steel	Stainless steel	Stainless steel	Stainless steel
<b>FEATURES</b>				
Knob material / no.	Steel / 2	Steel / 2	-	-
Teppanyaki (material)	-	Stainless steel	-	-
Grates (material)	Stainless steel	-	-	-
Tubular burners	2	2	-	-
Inner tub	Black enamel	Black enamel	-	-
Steel knob	-	-	•	•
Supply	Gas	Gas	-	-
Gastronorm grease-collection tray	•	•	-	-
Heating grid	-	-	•	-
Total gas burner power	7.6 kW	7.6 kW	-	-
Electronic ignition	•	•	-	-
Battery ignition	•	•	-	-
Thermometer	-	-	•	-
Gas types	NG - LPG	NG - LPG	-	-
<b>DIMENSIONS</b>				
Cooking zone width (mm)	440	440	-	-
Product (W x H x D) mm	615 x 189 x 540	615 x 189 x 540	490 x 191 x 600	490 x 54 x 559
Built-In Cut Out (W x H x D) mm	585 x 210 x 505	585 x 210 x 505	-	-

## CLUSTER

MULTIFUNCTION OVEN 90



FCLO 9615 TEM 2F BK	
Type	Electronic multifunction
Finish	Deep Black
Interiors: enamelled / other	Ultra Black Piro / -
<b>FEATURES</b>	
Efficiency class	A +
Capacity (litres)	100 L
Forced cooling	•
Functions no.	16
<b>PERFORMANCE</b>	
AirFry (oven-frying)	•
Max cooking temperature	250 °C
Interior dual convection	•
Assisted cleaning (CLEAN)	•
Grill power (W)	1750 +1100
Low-temperature slow cooking	•
<b>CONTROLS</b>	
Control type	Creactive Extended
Pre-loaded and editable recipes	•
Booster	•
Meat probe	•
On/off icon	•
Electronic temperature regulation	•
Single / double thermoventilated	- / •
Internal light	•
<b>SAFETY</b>	
Cool-touch door / no. of glass panes	• / 3
SOFT CLOSING door	•
<b>ACCESSORIES</b>	
Lighting (Halogen, 25 W) no.	2
Set of telescopic rails no.	1
Trays no. / type	1 / enamelled
Enamelled AirFry trays no.	1
Flat racks no.	1
Rotisserie	•
<b>POWER RATING</b>	
Max electrical power (W)	3500 W
Voltage / Frequency (V - Hz)	220 - 240 V; 50 - 60 Hz
Power cord	•
Plug	Schuko
<b>DIMENSIONS</b>	
Width (mm)	894
Height (mm)	588
Depth (mm)	564
Built-In Cut Out (W x H x D) mm	860 x 585 x 560

## CLUSTER

MULTIFUNCTION OVEN 75



FCLO 7515 TEM BK	
Type	Electronic multifunction
Finish	Deep Black
Interiors: enamelled / other	Ultra Black Piro / -
<b>FEATURES</b>	
Efficiency class	A +
Capacity (litres)	89 L
Forced cooling	•
Functions no.	16
<b>PERFORMANCE</b>	
AirFry (oven-frying)	•
Max cooking temperature	250 °C
Interior dual convection	-
Assisted cleaning (CLEAN)	•
Grill power (W)	1750 +1100
Low-temperature slow cooking	•
<b>CONTROLS</b>	
Control type	Creactive Extended
Pre-loaded and editable recipes	•
Booster	•
Meat probe	•
On/off icon	•
Electronic temperature regulation	•
Single / double thermoventilated	• / -
Internal light	•
<b>SAFETY</b>	
Cool-touch door / no. of glass panes	• / 3
SOFT CLOSING door	•
<b>ACCESSORIES</b>	
Lighting (Halogen, 25 W) no.	2
Set of telescopic rails no.	1
Trays no. / type	1 / enamelled
Enamelled AirFry trays no.	1
Flat racks no.	1
Rotisserie	•
<b>POWER RATING</b>	
Max electrical power (W)	3500W
Voltage / Frequency (V - Hz)	220 - 240 V; 50 - 60 Hz
Power cord	•
Plug	Schuko
<b>DIMENSIONS</b>	
Width (mm)	745
Height (mm)	589
Depth (mm)	564
Built-In Cut Out (W x H x D) mm	710 x 585 x 560

## CLUSTER

MULTIFUNCTION PYRO OVEN 75



FCLPO 7515 P TEM BK	
Type	Electronic multifunction
Finish	Deep Black
Interiors: enamelled / other	Ultra Black Piro / -
<b>FEATURES</b>	
Efficiency class	A +
Capacity (litres)	100 L
Forced cooling	•
Functions no.	16
<b>PERFORMANCE</b>	
Max cooking temperature	250 °C
Interior dual convection	•
Assisted cleaning (CLEAN)	•
<b>CONTROLS</b>	
Operating system	Creactive Extended
AirFry (oven-frying)	•
Pre-loaded and editable recipes	•
Auto power off	•
Booster	•
Meat probe	•
<b>SAFETY</b>	
Cool-touch door / no. of glass panes	• / 3
SOFT-CLOSING DOOR	•
<b>ACCESSORIES</b>	
Lighting (Halogen, 20 W) no.	2
Set of telescopic rails no.	2
Trays no. / type	1 / enamelled
Enamelled AirFry trays no.	1
Flat racks no.	1
Rotisserie kit	•
<b>POWER RATING</b>	
Max electrical power (W)	3500 W
Voltage / Frequency (V - Hz)	220 - 240 V; 50 - 60 Hz
Power cord	•
Plug	Schuko
<b>DIMENSIONS</b>	
Width (mm)	894
Height (mm)	590
Depth (mm)	564
Built-In Cut Out (W x H x D) mm	860 x 585 x 560

# CLUSTER

STEAM OVEN 75X45



FCLSO 7510 TEM BK	
Type	Combined Steam
Finish / Interiors: enamelled - other	Deep Black / Stainless steel
<b>FEATURES</b>	
Efficiency class	A ++
Capacity (litres)	34 L
Forced cooling	•
Functions no.	11
<b>PERFORMANCE</b>	
Max cooking temperature	230° C
Pre-loaded and editable recipes	•
AirFry (oven-frying)	•
Steam cooking 100° C / 130° C	• / •
Assisted cooking 100 °C	•
Mixed steam / convection	•
Defrosting (time/weight)	-
Assisted cleaning (CLEAN)	•
Microwave / Grill	-
Microwave / Convection	-
Microwave power (W)	-
Grill power (W)	1500 W
<b>CONTROLS</b>	
Control type	Creactive Extended
Easy Access	•
Meat probe	•
On/off icon	•
Forced cooling	•
Electronic temperature regulation	•
Internal light	•
<b>SAFETY</b>	
Safe door / no. of glass panes	• / 3
<b>ACCESSORIES</b>	
Lighting (Halogen, 25 W) no.	1
Removable Water Tank	•
S.Steel Gastronorm Tray	•
Standard Flat Grill Rack / removable no.	1 / 1
S.Steel Perforated Tray with Lid	•
<b>POWER RATING</b>	
Max electrical power (W)	3200 W
Voltage / Frequency (V - Hz)	220 - 240 V; 50 Hz
Power cord	•
Plug	Schuko
<b>DIMENSIONS</b>	
Width (mm)	745
Height (mm)	452
Depth (mm)	561
Built-In Cut Out (W x H x D) mm	710 x 450 x 560

# CLUSTER

MICROWAVE OVEN 75X45



FCLMO 7510 TEM BK	
Type	Combined Microwave
Finish / Interiors: enamelled - other	Deep Black / Stainless steel
<b>FEATURES</b>	
Efficiency class	-
Capacity (litres)	34 L
Forced cooling	•
Functions no.	10
<b>PERFORMANCE</b>	
Max cooking temperature	230° C
Pre-loaded and editable recipes	•
AirFry (oven-frying)	•
Steam cooking 100° C / 130° C	- / -
Assisted cooking 100 °C	-
Mixed steam / convection	-
Defrosting (time/weight)	•
Assisted cleaning (CLEAN)	-
Microwave / Grill	•
Microwave / Convection	•
Microwave power (W)	900 W
Microwave power levels	6
Grill power (W)	1500 W
<b>CONTROLS</b>	
Control type	Creactive Extended
Easy Access	•
On/off icon	•
Forced cooling	•
Electronic temperature regulation	•
Internal light	•
<b>SAFETY</b>	
Safe door / no. of glass panes	• / 3
<b>ACCESSORIES</b>	
Lighting (Halogen, 25 W) no.	1
S.Steel Gastronorm Tray	•
Standard Flat Grill Rack	•
Glass turntable plate	•
Round Grill Rack	•
<b>POWER RATING</b>	
Max electrical power (W)	3200 W
Voltage / Frequency (V - Hz)	220 - 240 V; 50 Hz
Power cord	•
Plug	Schuko
<b>DIMENSIONS</b>	
Width (mm)	745
Height (mm)	452
Depth (mm)	561
Built-In Cut Out (W x H x D) mm	710 x 450 x 560

# CLUSTER

ATMOS 60" STEAM OVEN



FCLSO 6023 TEM BK	
Type	Combined Steam
Dimension	60
Structure - Finish	Deep Black
Temperature regulation	Electronic
<b>FEATURES</b>	
Efficiency class	A++
Capacity (litres)	65
Forced cooling	•
Meat probe	•
Sizes	Timer 12 / 24 - Temperature °C / °F - Weight Kg / lb
Cooking functions	Classic 11      Steam 6      Special 7
Max cooking temperature	250 °C
Grill power (W)	1200 + 1000
Steam cooking autonomy	> 3 hours
Water tank capacity	1.5 l (Topping up without door opening)
Dashboard opening - touch control	•
<b>FUNCTIONS</b>	
	Classic Pizza function at 250 °C      AirFry (oven-frying)
	Steam cooking from 30 ° to 100°C      Pre-loaded and editable recipes
	Puff function      Low-temperature cooking
	Sous vide      Defrost function with steam
	Leavening function      Regeneration (180 °C)
<b>CONTROL PANEL</b>	
Display   Control type	TFT 3.5"   MODULAR - Electronic (double full touch keypad)
Fast recipe selection	•
Languages	15
<b>FEATURES</b>	
	Demo Mode      Steam cleaning function
	Beep volume setting      Circuit cleaning function
	Display brightness setting      Sabbath mode
	Descaling function      Event logs (for assistance)
<b>OVEN DOOR</b>	
Cool touch - no. of glass panes	3
Closure	soft closed
<b>ACCESSORIES</b>	
Side rack levels	5 (removable side racks)
Rectangular halogen light (25 W)	2
Fully removable telescopic rails	1 pair
S. Steel Gastronorm perforated trays	1
Gastronorm flat tray	1
AirFry enamel tray	1
Tray support frame	1
Enamelled trays	1
Flat racks	1
<b>DIMENSIONS</b>	
Product (W x H x D) mm	594 x 596 x 560
Built-In Cut Out (W x H x D) mm	560 x 895 x 560
<b>ELECTRICAL FEATURES</b>	
Max electrical power	3.50 kW
Voltage / Frequency (V - Hz)	220 - 240 V; 50 Hz
Power cord	•
Plug	Schuko

# CLUSTER

MULTIFUNCTION OVENS 60



	FCLPO 6215 P TEM BK	FCLO 6215 TEM BK
Type	Electronic self-cleaning multifunction	Electronic multifunction
Finish	Deep Black	Deep Black
Interiors: enamelled / other	Ultra Black Piro / -	Ultra Black Piro / -
<b>FEATURES</b>		
Efficiency class	A +	A ++
Capacity (litres)	65 L	65 L
Forced cooling	•	•
Functions no.	18	16
<b>PERFORMANCE</b>		
Ma cooking temperature	290 °C	250 °C
Pizza Pizzeria 350 °C function	350 °C	-
AirFry (oven-frying)	•	•
Pyrolysis temperature	470 °C	-
Pyrolytic	•	-
Assisted cleaning (CLEAN)	-	•
Grill power (W)	1200 +1000	1200 +1000
Low-temperature slow cooking	•	•
<b>CONTROLS</b>		
Control type	Creactive Extended	Creactive Extended
Pre-loaded and editable recipes	•	•
Booster	•	•
Meat probe	•	•
Fume catalyst	•	-
On/off icon	•	•
Thermostat	•	•
Thermovenilated	•	•
Internal light	•	•
<b>SAFETY</b>		
Door lock (during pyrolysis)	•	-
Cool-touch door / no. of glass panes	• / 4	• / 3
SOFT-CLOSING DOOR	•	•
<b>ACCESSORIES</b>		
Lighting (Halogen, 25 W) no.	2	2
Set of telescopic rails no.	2	1
Trays no. / type	1 / enamelled	1 / enamelled
Enamelled AirFry trays no.	1	1
Flat racks no.	1	1
Round rack no.	1	-
Firestone for pizza no.	1	-
Pizza Shovel	•	-
<b>POWER RATING</b>		
Max electrical power (W)	3450 W	3500 W
Voltage / Frequency (V - Hz)	220 - 240 V; 50 - 60 Hz	220 - 240 V; 50 - 60 Hz
Power cord	•	•
Plug	Schuko	Schuko
<b>DIMENSIONS</b>		
Width (mm)	594	594
Height (mm)	596	596
Depth (mm)	560	560
Built-In Cut Out (W x H x D) mm	560 x 585 x 560	560 x 585 x 560

# CLUSTER

45" OVENS



	FCLCSO 4510 TEM BK	FCLCMO 4510 TEM BK	FCLGMO 4508 TEM BK
Type	Combined Steam	Combined Microwave	Microwave with grill
Finish	Deep Black	Deep Black	Deep Black
Interiors: enamelled / other	Stainless steel	Stainless steel	Stainless steel
<b>FEATURES</b>			
Efficiency class	A ++	-	-
Capacity (litres)	34 L	34 L	34 L
Forced cooling	•	•	•
Functions no.	11	10	5
<b>PERFORMANCE</b>			
Max cooking temperature	230° C	230° C	230° C
Pre-loaded and editable recipes	•	•	•
AirFry (oven-frying)	•	•	-
Steam cooking 100° C / 130° C	• / •	- / -	- / -
Assisted cooking 100 °C	•	-	-
Mixed steam / convection	•	-	-
Defrosting (time/weight)	-	•	•
Assisted cleaning (CLEAN)	•	-	-
Microwave / Grill	-	•	•
Microwave / Convection	-	•	-
Microwave power (W)	-	900 W	900 W
Microwave power levels	-	6	6
Grill power (W)	1500 W	1500 W	1500 W
<b>CONTROLS</b>			
Control type	Creactive Extended	Creactive Extended	Creactive Extended
Easy Access	•	•	•
Meat probe	•	-	-
On/off icon	•	•	•
Electronic temperature regulation	•	•	•
Forced cooling	•	•	•
Internal light	•	•	•
<b>SAFETY</b>			
Safe door / no. of glass panes	• / 3	• / 3	• / 3
<b>ACCESSORIES</b>			
Lighting (Halogen, 25 W) no.	1	1	1
Removable Water Tank	•	-	-
S.Steel Gastronorm Tray	•	•	•
Standard Flat Grill Rack / removable no.	1 / 1	1 / -	1 / -
S.Steel Perforated Tray with Lid	•	-	-
Glass turntable plate	-	•	•
Round Grill Rack	-	•	•
<b>POWER RATING</b>			
Max electrical power (W)	3200 W	3200 W	3200 W
Voltage / Frequency (V - Hz)	220 - 240 V; 50 Hz	220 - 240 V; 50 Hz	220 - 240 V; 50 Hz
Power cord	•	•	•
Plug	Schuko	Schuko	Schuko
<b>DIMENSIONS</b>			
Width (mm)	594	594	594
Height (mm)	452	452	452
Depth (mm)	562	562	562
Built-In Cut Out (W x H x D) mm	560 x 450 x 560	560 x 450 x 560	560 x 450 x 560

# CLUSTER

BLAST CHILLER 45



FCLBC 4500 TF BK	
Type	Blast chiller multifunction
Finish	Deep Black
Interiors: enamelled / other	Stainless steel
<b>FEATURES</b>	
Volume (litres)	40 L
Total functions no.	11
Cold functions	7
Hot functions	4
<b>PERFORMANCE</b>	
Sanitation -30°C	•
Blast chilling up to + 3°C	•
Deep-freezing up to 18 °C	•
Timed cooling	•
Bottle cooling	•
Low-temperature cooking up to +75 °C	•
Regeneration	•
Ready to serve	•
<b>CONTROLS</b>	
Control type	TFT Display
Auto power off	•
<b>SAFETY</b>	
Control lock	•
<b>ACCESSORIES</b>	
Lighting (Halogen, 25 W) no.	1
Flat metal racks / glass tray no.	1 / 1
<b>POWER RATING</b>	
Max electrical power (W)	300 W
Voltage / Frequency (V - Hz)	230 / 50
Power cord	•
Plug	Schuko
<b>DIMENSIONS</b>	
Width (mm)	594
Height (mm)	452
Depth (mm)	571
Built-In Cut Out (W x H x D) mm	560 x 450 x 560

# URBANTECH TOUCH

PYRO OVEN 30

NEW



FUTPO 315 P TEM 2F..	
Type	Electronic pyrolytic multifunction
Finish	Matte Black Metal <b>MBK</b> Stainless Steel <b>IX</b>
Interiors: enamelled / other	Ultra Black Pyro
<b>FEATURES</b>	
Efficiency class	A
Capacity (litres)	125 L
Forced cooling	•
Functions no.	18
<b>PERFORMANCE</b>	
Max cooking temperature	290 °C
Pizza Pizzeria 350°C	350 °C
AirFry (oven-frying)	•
Pyrolysis temperature	460°C
Interior dual convection	•
Pyrolysis	•
<b>CONTROLS</b>	
Operating system	Creactive Extended
Pre-loaded and editable recipes	•
Auto power off	•
Booster	•
Meat probe	•
<b>SAFETY</b>	
Door lock (during pyrolysis)	•
Cool-touch door / no. of glass panes	• / 4
<b>ACCESSORIES</b>	
Lighting (Halogen, 20 W) no.	3
Set of telescopic rails no.	2
Trays no. / type	1 / enamelled
Enamelled AirFry trays no.	1
Flat racks no.	1
Round pizza rack	•
Pizza Stone	•
Pizza shovel	•
<b>POWER RATING</b>	
Max electrical power (W)	3650 W
Voltage / Frequency (V - Hz)	220 - 240 V; 50 - 60 Hz
Power cord	•
<b>DIMENSIONS</b>	
Width (mm)	754
Height (mm)	707
Depth (mm)	610
Built-In Cut Out (W x H x D) mm	722 x 696 x 610

# URBANTECH TOUCH

30" STEAM OVEN

NEW



NEW



	FUTSO 310 TEM...	FUTMO 310 TEM...
Type	Combined Steam	Combined Microwave
Finish	Matte Black Metal Stainless Steel	Matte Black Metal Stainless Steel
	<b>MBK</b> <b>IK</b>	<b>MBK</b> <b>IK</b>
<b>FUNCTIONS</b>		
Temperature regulation	Electronic	Electronic
Steam cooking / Microwave	• / -	- / •
AirFry (oven-frying)	•	•
Steam heating	•	-
Steam convection oven	•	-
Steam cleaning / circuit	•	-
Puff function	•	-
Convection bake	•	•
Convection roast	•	•
Grilling	•	•
Eco Convection bake	•	-
Recipes	•	•
Oven lights	•	•
<b>CONTROL PANEL</b>		
Operating system	Creative Extended	Creative Extended
Display	TFT 3.5"	TFT 3.5"
Recipe menu	•	•
Controls / Languages	Double Full Touch Display / 15	Double Full Touch Display / 15
<b>FEATURES</b>		
Meat probe	•	-
12 / 24 clock format   °C / °F	•	-
Cool-touch door	•	•
<b>OVEN CAPACITY</b>		
Gross capacity (litres)	34 L	34 L
Interiors:	Stainless steel	Stainless steel
Rack position	3	3
Lighting (Halogen, 25 W) no.	1	1
Upper heating element for grilling	1500 W	1500 W
Steam generator / microwave	800 W	900 W
Lower heating element power	300 W	-
Convection element power	1500 W	1500 W
<b>ACCESSORIES</b>		
Removable Water Tank	•	-
S.Steel Gastronorm Tray	•	•
Standard Flat Grill Rack / removable no.	1 / 1	1 / -
S.Steel Perforated Tray with Lid	•	-
Glass turntable plate	-	•
Round Grill Rac	-	•
<b>POWER RATING</b>		
Max oven electrical power (W)	3200 W	3200 W
Voltage / Frequency (V - Hz)	220 - 240V; 50 Hz	220 - 240V; 50 Hz
Cord / Plug	• / Schuko	• / Schuko
<b>DIMENSIONS</b>		
Dim. Product (W x H x D) mm	754 x 474 x 564	754 x 474 x 564
Built-In Cut Out (W x H x D) mm	722 x 463 x 560 *	722 x 463 x 560 *

# URBANTECH TOUCH

MULTIFUNCTION PYRO OVEN 75

NEW



	FUTO 9615 TEM 2F...
Type	Electronic multifunction
Finish	Matte Black Metal Stainless steel
	<b>MBK</b> <b>IX</b>
<b>FEATURES</b>	
Interiors: enamelled	Ultra Black
Efficiency class	A +
Capacity (litres)	100 L
Forced cooling	•
Functions no.	16
<b>PERFORMANCE</b>	
Max cooking temperature	250 °C
Interior dual convection	•
Assisted cleaning (CLEAN)	•
<b>CONTROLS</b>	
Operating system	Creative Extended
AirFry (oven-frying)	•
Pre-loaded and editable recipes	•
Auto power off	•
Booster	•
Meat probe	•
<b>SAFETY</b>	
Cool-touch door / no. of glass panes	• / 3
<b>ACCESSORIES</b>	
Lighting (Halogen, 20 W) no.	2
Set of telescopic rails no.	2
Trays no. / type	1 / enamelled
Enamelled AirFry trays no.	1
Flat racks no.	1
Rotisserie kit	•
<b>POWER RATING</b>	
Max electrical power (W)	3500 W
Voltage / Frequency (V - Hz)	220 - 240 V; 50 - 60 Hz
Power cord	•
Plug	Schuko
<b>DIMENSIONS</b>	
Width (mm)	894
Height (mm)	590
Depth (mm)	564
Built-In Cut Out (W x H x D) mm	860 x 585 x 560

# URBANTECH TOUCH

MULTIFUNCTION OVENS 90

NEW



	FUTO 7515 P TEM...
Type	Electronic pyrolytic multi
Finish	Matte Black Metal Stainless steel
	<b>MBK</b> <b>IX</b>
<b>FEATURES</b>	
Interiors: enamelled	Ultra Black Pyro
Efficiency class	A +
Capacity (litres)	89 L
Forced cooling	•
Functions no.	18
<b>PERFORMANCE</b>	
Max cooking temperature	250°C
Pizza Pizzeria function	350°C
AirFry (oven-frying)	•
Pyrolysis temperature	470°C
Pyrolytic	•
<b>CONTROLS</b>	
Operating system	Creative Extended
Pre-loaded and editable recipes	•
Auto power off	•
Booster	•
Meat probe	•
<b>SAFETY</b>	
Door lock (during pyrolysis)	•
Cool-touch door / no. of glass panes	• / 4
Soft Closing	•
<b>ACCESSORIES</b>	
Lighting (Halogen, 20 W) no.	2
Set of telescopic rails no.	2
Trays no. / type	1 / enamelled
Enamelled AirFry trays no.	1
Flat racks no.	1
Round pizza rack	•
Pizza Stone	•
Pizza shove	•
<b>POWER RATING</b>	
Max electrical power (W)	3500 W
Voltage / Frequency (V - Hz)	220 - 240 V; 50 - 60 Hz
Power cord	•
Plug	Schuko
<b>DIMENSIONS</b>	
Width (mm)	745
Height (mm)	591
Depth (mm)	567
Built-In Cut Out (W x H x D) mm	710 x 590 x 560

NEW

## URBANTECH TOUCH

MULTIFUNCTION OVEN 75



FUTO 7515 TEM...	
Type	Electronic multifunction
Finish	Matte Black Metal MBK Stainless Steel IX
<b>FEATURES</b>	
Interiors: enamelled	Ultra Black
Efficiency class	A +
Capacity (litres)	89 L
Forced cooling	•
Functions n.	16
<b>PERFORMANCE</b>	
Max cooking temperature	250°C
AirFry (oven-frying)	•
Assisted cleaning (CLEAN)	•
<b>CONTROLS</b>	
Operating system	Creactive Extended
Pre-loaded and editable recipes	•
Auto power off	•
Booster	•
Meat probe	•
<b>SAFETY</b>	
Cool-touch door / no. of glass panes	• / 3
SOFT CLOSING door	•
<b>ACCESSORIES</b>	
Lighting (Halogen, 20 W) no.	2
Set of telescopic rails no.	2
Trays no. / type	1 / enamelled
Enamelled AirFry trays no.	1
Flat racks no.	1
Rotisserie kit	•
<b>POWER RATING</b>	
Max electrical power (W)	3500 W
Voltage / Frequency (V - Hz)	220 - 240 V ; 50 - 60 Hz
Power cord	•
Plug	Schuko
<b>DIMENSIONS</b>	
Width (mm)	745
Height (mm)	591
Depth (mm)	567
Built-In Cut Out (W x H x D) mm	710 x 590 x 560

NEW

## URBANTECH TOUCH

STEAM OVEN 75X45



FUTCSO 7510 TEM...	
Type	Combined Steam
Finish	Matte Black Metal MBK Stainless Steel IX
<b>FEATURES</b>	
Interiors: enamelled / other	Stainless steel
Efficiency class	A ++
Capacity (litres)	34 L
Forced cooling / Meat probe	• / •
Functions n.	11
<b>PERFORMANCE</b>	
Max cooking temperature	230°C
AirFry (oven-frying)	•
Pre-loaded and editable recipes	•
Steam 100 °C / 130 °C	• / •
Steam puff 100 °C	•
Steam + Thermoventilated	•
Assisted cleaning (CLEAN)	•
Grill power (W)	1500 W
<b>CONTROLS</b>	
Operating system	Creactive Extended
Easy access / Auto power off	• / •
<b>SAFETY</b>	
Safe door / no. of glass panes	• / 3
Safety switch	•
<b>ACCESSORIES</b>	
Lighting (Halogen, 25 W) no.	1
Removable water tank	1,4 L
S.Steel Gastronorm Tray	1 / Inox AISI 304
Standard Flat Grill Rack / removable no.	1 / 1
S.Steel Perforated Tray with Lid	•
<b>POWER RATING</b>	
Max electrical power (W)	3200 W
Voltage / Frequency (V - Hz)	220 - 240 V ; 50 Hz
Power cord / Plug	• / Schuko
<b>DIMENSIONS</b>	
Width (mm)	745
Height (mm)	452
Depth (mm)	562
Built-In Cut Out (W x H x D) mm	710 x 450 x 560

NEW

## URBANTECH TOUCH

MICROWAVE OVEN 75X45



FUTCMO 7510 TEM...	
Type	Combined Microwave
Finish	Matte Black Metal MBK Stainless Steel IX
<b>FEATURES</b>	
Interiors: enamelled	Stainless steel
Capacity (litres)	34 L
Forced cooling	•
Functions no.	10
<b>PRESTAZIONI</b>	
Max cooking temperature	230°C
AirFry (oven-frying)	•
Pre-loaded and editable recipes	•
Defrosting (time/weight)	•
Microwave with grill	• / •
Microwave + Convection	•
Microwave power (W)	900 W
Microwave power levels	6
Grill power (W)	1500 W
<b>CONTROLS</b>	
Operating system	Creactive Extended
Auto power off	•
<b>SAFETY</b>	
Door with safety switch	•
Safe door / no. of glass panes	• / 3
Panel lock	•
<b>ACCESSORI</b>	
Lighting (Halogen, 25 W) no.	1
S.Steel Gastronorm Tray	1 / •
Glass turntable plate	•
Round Grill Rack	•
<b>POWER RATING</b>	
Max electrical power (W)	3200 W
Voltage / Frequency (V - Hz)	220 - 240 V ; 50 Hz
Power cord / Plug	• / Schuko
<b>DIMENSIONS</b>	
Width (mm)	745
Height (mm)	452
Depth (mm)	562
Built-In Cut Out (W x H x D) mm	710 x 450 x 560

NEW

## URBANTECH TOUCH

ATMOS STEAM OVEN 60



FUTO 6023 TEM...	
Type / Dimension	Combined Steam/ 60
Finish	Matte Black Metal Stainless steel <b>MBK IX</b>
Temperature regulation	Electronic
<b>FEATURES</b>	
Efficiency class	A++
Capacity (litres)	65
Forced cooling / Meat probe	• / •
Sizes	Timer 12 / 24 - Temperature °C / °F - Weight Kg / lb
Cooking functions	Classic 11      Steam 6      Special 7
Max cooking temperature	250 °C
Grill power (W)	1200 + 1000
Steam cooking autonomy	> 3 hours
Water tank capacity	1.5 l (Topping up without door opening)
Dashboard opening - touch control	•
<b>FUNCTIONS</b>	
	Classic Pizza function at 250 °C      AirFry (oven-frying)
	Steam cooking from 30 ° to 100°C      Pre-loaded and editable recipes
	Puff function      Low-temperature cooking
	Sous vide      Defrost function with steam
	Leavening function      Regeneration (180 °C)
<b>CONTROL PANEL</b>	
Display   Control type	TFT 3.5"   MODULAR - Electronic (double full touch keypad)
Fast recipe selection / Languages	• / 15
<b>FEATURES</b>	
	Demo Mode      Steam cleaning function
	Beep volume setting      Circuit cleaning function
	Display brightness setting      Sabbath mode
	Descaling function      Event logs (for assistance)
<b>OVEN DOOR</b>	
Cool touch - no. of glass panes	3
Closure	soft closing
<b>ACCESSORIES</b>	
Side rack levels	5 (removable side racks)
Rectangular halogen light (20 W)	2
Fully removable telescopic rails	1 pair
S. Steel Gastronorm perforated tray	1
Gastronorm tray	1
Tray support frame	1
Enamelled trays	1
Enamelled tray AirFry	1
Flat racks	1
<b>DIMENSIONS</b>	
Product (W x H x D) mm	594 x 596 x 560
Built-In Cut Out (W x H x D) mm	560 x 585 x 560
<b>ELECTRICAL FEATURES</b>	
Max electrical power	3.50 kW
Voltage / Frequency (V - Hz)	220 - 240 V; 50 Hz
Power cord / Plug	• / Schuko

NEW

## URBANTECH TOUCH

PIRO MULTIFUNCTION OVEN 60



FUTPO 6215 P TEM...	
Type	Electronic pyrolytic multifunction
Finish	Matte Black Metal Stainless Steel <b>MBK IX</b>
<b>FEATURES</b>	
Interiors: enamelled	Ultra Black Pyro
Efficiency class	A +
Capacity (litres)	65 L
Forced cooling	•
Functions n.	18
<b>PERFORMANCE</b>	
Max cooking temperature	290°C
Pizza Pizzeria function	350°C
AirFry (oven-frying)	•
Pyrolytic / Pyrolysis temperature	• / 470°C
<b>CONTROLS</b>	
Operating system	Creative Extended
Pre-loaded and editable recipes	•
Auto power off	•
Booster	•
Meat probe	•
<b>SAFETY</b>	
Door lock (during pyrolysis)	•
Cool-touch door / no. of glass panes	• / 4
SOFT CLOSING door	•
<b>ACCESSORIES</b>	
Lighting (Halogen, 20 W) no.	2
Set of telescopic rails no.	2
Trays no. / type	1 / enamelled
Enamelled AirFry trays n.	1
Flat racks n. / Round pizza rack	1 / •
Pizza Stone/ Pizza shovel	• / •
<b>POWER RATING</b>	
Max electrical power (W)	3450 W
Voltage / Frequency (V - Hz)	220 - 40 / 50 - 60 Hz
Power cord / Plug	• / Schuko
<b>DIMENSIONS</b>	
Width (mm)	594
Height (mm)	596
Depth (mm)	560
Built-In Cut Out (W x H x D) mm	560 x 585 x 560

NEW

## URBANTECH TOUCH

MULTIFUNCTION OVEN 60



FUTO 6215 TEM...	
Type / Finish	Electronic multifunction
Finish	Matte Black Metal Stainless Steel <b>MBK IX</b>
Dimension	60
<b>FEATURES</b>	
Interiors: enamelled	Ultra Black
Efficiency class	A ++
Capacity (litres)	65 L
Functions n.	16
Forced cooling	•
<b>PERFORMANCE</b>	
Max cooking temperature	250°C
Assisted cleaning (CLEAN)	•
<b>CONTROL</b>	
Operating system	Creative Extended
AirFry (oven-frying)	•
Pre-loaded and editable recipes	•
Auto power off	•
Booster	•
Meat probe	•
<b>SAFETY</b>	
Cool-touch door	•
N. of glass panes	3
Soft Closing	•
<b>ACCESSORIES</b>	
Lighting (Halogen, 25 W) n.	2
Set of telescopic rails n.	2
Trays no. / type	1 / enamelled
Enamelled Airfry trays	1
Flat racks n.	1
<b>POWER RATING</b>	
Max electrical power (W)	3500W
Voltage / Frequency (V - Hz)	220 - 240 V ; 50 - 60 Hz
Power cord	•
Plug	Schuko
<b>DIMENSIONS</b>	
Width (mm)	594
Height (mm)	596
Depth (mm)	560
Built-In Cut Out (W x H x D) mm	560 x 585 x 560

NEW

## URBANTECH TOUCH

45 STEAM OVEN COMBI



FULTSO 4510 TEM...	
Type	Combined Steam
Finish	Matte Black Metal <b>MBK</b> Stainless Steel <b>IX</b>
<b>FEATURES</b>	
Interiors: enamelled / other	Stainless steel
Efficiency class	A ++
Capacity (litres)	34 L
Forced cooling / Meat probe	• / •
Functions n.	11
<b>PERFORMANCE</b>	
Max cooking temperature	230°C
AirFry (oven-frying)	•
Pre-loaded and editable recipes	•
Steam 100 °C / 130 °C	• / •
Puff function	•
Steam + Thermoventilated	•
Assisted cleaning (CLEAN)	•
Grill power (W)	1500 W
<b>CONTROLS</b>	
Operating system	Creactive Extended
Easy access / Auto power off	• / •
<b>SAFETY</b>	
Safe door / n. of glass panes	• / 3
Safety switch	•
<b>ACCESSORIES</b>	
Lighting (Halogen, 25 W) no.	1
Removable Water Tank	1,4 L
S.Steel Gastronorm Tray / Type	1 / Inox AISI 304
Standard Flat Grill Rack / removable n.	1 / 1
S.Steel Perforated Tray with Lid	•
<b>POWER RATING</b>	
Max electrical power (W)	3200 W
Voltage / Frequency (V - Hz)	220 - 240 V ; 50 Hz
Power cord / Plug	• / Schuko
<b>DIMENSIONS</b>	
Width (mm)	594
Height (mm)	452
Depth (mm)	562
Built-In Cut Out (W x H x D) mm	560 x 450 x 560

NEW

## URBANTECH TOUCH

MICROWAVE OVEN 60X45



FUTMO 4510 TEM...	
Type	Combined Microwave
Finish	Matte Black Metal <b>MBK</b> Stainless SSteel <b>IX</b>
<b>FEATURES</b>	
Interiors: enamelled / other	Stainless steel
Capacity (litres)	34 L
Forced cooling	•
Functions n.	10
<b>PERFORMANCE</b>	
Max cooking temperature	230°C
AirFry (oven-frying)	•
Pre-loaded and editable recipes	•
Defrosting (time/weight)	•
Microwave with grill	• / •
Microwave + Convection	•
Microwave power (W)	900 W
Microwave power levels	6
Grill power (W)	1500 W
<b>CONTROLS</b>	
Operating system	Creactive Extended
Auto power off	•
<b>SAFETY</b>	
Door with safety switch	•
Safe door / no. of glass panes	• / 3
Panel lock	•
<b>ACCESSORIES</b>	
Lighting (Halogen, 25 W) no	1
S.Steel Gastronorm Tray / plane grid	1 / •
Glass turntable plate	•
Round Grill Rack	•
<b>POWER RATING</b>	
Max electrical power (W)	3200 W
Voltage / Frequency (V - Hz)	220 - 240 V ; 50 Hz
Power cord / Plug	• / Schuko
<b>DIMENSIONS</b>	
Width (mm)	594
Height (mm)	452
Depth (mm)	562
Built-In Cut Out (W x H x D) mm	560 x 450 x 560

# URBANTECH

MULTIFUNCTION OVEN 90



Type	Multifunction
Code FUTO 9609 MT IX Code FUO 9609 MT MBK	Stainless steel Matte Black Metal
Interiors: enamelled / other	Black
<b>FEATURES</b>	
Efficiency class	A
Capacity (litres)	100 L
Forced cooling	•
Functions no.	9
<b>PERFORMANCE</b>	
Max cooking temperature	250 °C
Assisted cleaning (CLEAN)	•
<b>CONTROLS</b>	
Control type	Digital timer + Knobs
Auto power off	•
<b>SAFETY</b>	
Safe door / no. of glass panes	• / 3
SOFT-CLOSING DOOR	•
<b>ACCESSORIES</b>	
Lighting (Halogen, 25 W) no.	2
Set of telescopic rails no.	1
Trays no. / type	1 / enamelled
Flat racks no. / rotisserie kit	1 / •
<b>POWER RATING</b>	
Max electrical power (W)	3500 W
Voltage / Frequency (V - Hz)	220 - 240 V; 50 - 60 Hz
Power cord / Plug	• / Schuko
<b>DIMENSIONS</b>	
Dim. Product (W x H x D) mm	894 x 588 x 564
Built-In Cut Out (W x H x D) mm	860 x 585 x 560

# URBANTECH

VENTILATED GAS OVEN 90



Type	Gas ventilated   Anti-fingerprint
Cod. FUTO 9605 FG EM 2F IX Cod. FUTO 9605 FG EM 2F GBK Cod. FUTO 9605 FG EM 2F MBK	Stainless steel Black Glass Matte Black Metal
<b>FEATURES</b>	
Interiors: enamelled / other	Black
Efficiency class	A
Volume (litres)	97 L
Tangential ventilation	•
Functions no.	4
<b>PERFORMANCE</b>	
Max cooking temperature	250°C
<b>CONTROLS</b>	
Control type	Timer touch + Knobs
<b>SAFETY</b>	
Safe door / no. of glass panes	• / 3
<b>ACCESSORIES</b>	
Lighting (Halogen, 25 W) no.	2
Set of telescopic rails no.	1
Trays no. / type	1 / smalto
Flat racks no. / Rotisserie kit	1 / •
<b>POWER RATING</b>	
Max electrical power (W)	1800 W
Power supply (V - Hz)	220 - 240 V ; 50 - 60 Hz
Power cord	•
Plug	Schuko
<b>DIMENSIONS</b>	
Width (mm)	894
Height (mm)	588
Depth (mm)	564
Built-In Cut Out (W x H x D) mm	860 x 585 x 560

## URBANTECH

MULTIFUNCTION OVEN 75



Type	Multifunction
Code FUTO 7509 MT IX Code FUTO 7509 MT GBK Code FUIO 7509 MT MBK	Stainless Steel Black Glass Matte Black Metal
Interiors: enamelled / other	Ultra Black Piro / -
<b>FEATURES</b>	
Efficiency class	A
Capacity (litres)	89 L
Forced cooling	•
Functions no.	9
<b>PERFORMANCE</b>	
Max cooking temperature	250 °C
<b>CONTROLS</b>	
Control type	Timer touch + Knobs
Auto power off	•
<b>SAFETY</b>	
Safe door / no. of glass panes	• / 3
SOFT CLOSING door	•
<b>ACCESSORIES</b>	
Lighting (Halogen, 25 W) no.	2
Set of telescopic rails no.	1
Trays no. / type	1 / enamelled
Flat racks no.	1
Rotisserie kit	•
<b>POWER RATING</b>	
Max electrical power (W)	3500 W
Voltage / Frequency (V - Hz)	220 - 240V; 50 - 60 Hz
Power cord / Plug	• / Schuko
<b>DIMENSIONS</b>	
Width (mm)	745
Height (mm)	589
Depth (mm)	564
Built-In Cut Out (W x H x D) mm	710 x 585 x 560

## URBANTECH

STEAM OVEN 75X45



Type	Steam with grill
Code FUSO 7505 MT IX Code FUSO 7505 MT GBK Code FUSO 7505 MT MBK	Stainless Steel Black Glass Matte Black Metal
<b>FEATURES</b>	
Interiors: enamelled / other	Stainless steel
Capacity (litres)	34 L
Forced cooling	•
Functions no.	2
<b>PERFORMANCE</b>	
Max cooking temperature	230 °C
Steam100 °C / 130 °C	• / -
Grill power (W)	900 W
Cooking with Grill	•
<b>CONTROLS</b>	
Control type	Digital timer + Knobs
Auto power off	•
<b>SAFETY</b>	
Safe door / no. of glass panes	• / 3
<b>ACCESSORIES</b>	
Stainless steel steam set	Microperforated tray with lid, liquid-collection tray and support
Flat grill racks no.	1
Water tank no.	1
<b>POWER RATING</b>	
Max electrical power (W)	1200 W
Voltage / Frequency (V - Hz)	220 - 240 V; 50 Hz
Power cord / Plug	• / Schuko
<b>DIMENSIONS</b>	
Width (mm)	745
Height (mm)	452
Depth (mm)	562
Built-In Cut Out (W x H x D) mm	710 x 450 x 560

## URBANTECH

MICROWAVE OVEN 75X45



Type	Microwave with grill
Code FUGMO 7505 MT IX Code FUGMO 7505 MT GBK Code FUGMO 7505 MT MBK	Stainless steel Black Glass Matte Black Metal
<b>FEATURES</b>	
Interiors: enamelled / other	Stainless steel
Capacity (litres)	34 L
Forced cooling	•
Functions no.	3
<b>PERFORMANCE</b>	
Max cooking temperature	230 °C
Grill power (W)	1500 W
Microwave power (W)	900 W
Microwave power levels	6
Cooking with Grill	•
<b>CONTROLS</b>	
Control type	Digital timer + Knobs
Auto power off	•
<b>SAFETY</b>	
Safe door / no. of glass panes	• / 3
<b>ACCESSORIES</b>	
Flat grill racks no.	1
Round grill rack / Glass turntable plate	• / •
<b>POWER RATING</b>	
Max electrical power (W)	3200 W
Voltage / Frequency (V - Hz)	220 - 240 V; 50 Hz
Power cord	•
Plug	Schuko
<b>DIMENSIONS</b>	
Width (mm)	745
Height (mm)	452
Depth (mm)	562
Built-In Cut Out (W x H x D) mm	710 x 450 x 560

## URBANTECH

PIRO MULTIFUNCTION OVEN 60



Type	Self-cleaning multifunction
Cod. FUTO 6011 P MT IX Cod. FUTO 6011 P MT GBK Cod. FUIO 6011 P MT MBK	Stainless steel Black Glass Matte Black Metal
Interiors: enamelled / other	Ultra Black Piro / -
<b>FEATURES</b>	
Efficiency class	A +
Capacity (litres) / Functions no.	65 L / 9
Forced cooling	•
<b>PERFORMANCE</b>	
Max cooking temperature	250° C
Pyrolysis temperature	470° C
Pyrolytic	•
<b>CONTROLS</b>	
Control type	Digit Control with knobs
Auto power off	•
Booster	-
Internal light	•
<b>SAFETY</b>	
Door lock (during pyrolysis)	•
Cool-touch door / no. of glass panes	• / 4
<b>ACCESSORIES</b>	
Lighting (Halogen, 25 W) no.	2
Set of telescopic rails no.	1
Trays no. / type	1 / enamelled
Flat racks no.	2
<b>POWER RATING</b>	
Max electrical power (W)	3350 W
Voltage / Frequency (V - Hz)	220 - 240 V; 50 - 60 Hz
Power cord / Plug	• / Schuko
<b>DIMENSIONS</b>	
Dim. Product (W x H x D) mm	594 x 596 x 560
Built-In Cut Out (W x H x D) mm	560 x 585 x 560

## URBANTECH

MULTIFUNCTION OVEN 60



Type	Multifunction
Code FUTO 6009 MT IX Code FUTO 6009 MT GBK Code FJO 6009 MT MBK	Stainless steel Black Glass Matte Black Metal
FEATURES	
Interiors: enamelled / other	Ultra Black Piro / -
Efficiency class	A
Capacity (litres)	65 L
Forced cooling / Functions no.	• / 9
PERFORMANCE	
Max cooking temperature	250 °C
Assisted cleaning (CLEAN)	•
CONTROLS	
Control type	Digital timer with knobs
Auto power off / Internal light	• / •
SAFETY	
Cool-touch door / no. of glass panes	• / 3
SOFT-CLOSING DOOR	•
ACCESSORIES	
Lighting (Halogen, 25 W) no.	1
Set of telescopic rails no.	1
Trays no. / type   flat racks no.	1 / enamelled   1
POWER RATING	
Max electrical power (W)	3500 W
Voltage / Frequency (V - Hz)	220 - 240 V; 50 - 60 Hz
Power cord	•
Plug	Schuko
DIMENSIONS	
Dim. Product (W x H x D) mm	594 x 596 x 560
Built-In Cut Out (W x H x D) mm	560 x 585 x 560

## URBANTECH

VENTILATED GAS OVEN 60



Type	Gas ventilated
Cod. FUTO 6005 FG EM IX Cod. FUTO 6005 FG EM GBK Cod. FUTO 6005 FG EM MBK	Stainless steel Black Glass Matte Black Metal
FEATURES	
Interiors: enamelled / other	Black
Efficiency class	A +
Volume (litres)	64 L
Tangential ventilation	•
Total functions no.	3
PERFORMANCE	
Max cooking temperature	250°C
Assisted cleaning (CLEAN)	•
CONTROLS	
Control type	Digital timer with knobs
SAFETY	
Safe door / no. of glass panes	• / 3
SOFT-CLOSING DOOR	•
ACCESSORIES	
Lighting (Halogen 25 W) no.	1
Trays no. / type	1/ enamel
Flat racks no.	1
Rotisserie kit	•
CARATTERISTICHE ELETTRICHE	
Potenza max assorbita (W)	1200W
Alimentazione (V - Hz)	220 - 240 V ; 50 - 60 Hz
Cavo di alimentazione / Spina	• / Schuko
DIMENSIONS	
Dim. Product (W x H x D) mm	594 x 596 x 560
Recessed compartment (L x H x D) mm	560 x 585x 560

## URBANTECH

GRILL STEAM OVEN 45



Type	Steam with grill
Code FUTGSO 4505 MT IX Code FUTGSO 4505 MT GBK Code FUSO 4505 MT MBK	Stainless Steel Black Glass Matte Black Metal
FEATURES	
Interiors: enamelled / other	Stainless steel
Capacity (litres)	34 L
Forced cooling	•
Functions no.	2
PERFORMANCE	
Max cooking temperature	230 °C
Steam100 °C / 130 °C	• / -
Grill power (W) / Cooking with Grill	900 W / •
CONTROLS	
Control type	Digital timer + Knobs
Auto power off	•
SAFETY	
Safe door / no. of glass panes	• / 3
ACCESSORIES	
Stainless steel steam set	Micro-perforated tray with lid, liquid-collection tray and support
Flat grill racks no.	1
Water tank no.	1
POWER RATING	
Max electrical power (W)	1200 W
Voltage / Frequency (V - Hz)	220 - 240 V; 50 Hz
Power cord / Plug	• / Schuko
DIMENSIONS	
Dim. Product (W x H x D) mm	594 x 452 x 562
Built-In Cut Out (W x H x D) mm	560 x 450 x 560

## URBANTECH

MICROWAVE AND GRILL OVEN 45



Type	Microwave with grill
Code FUTGMO 4505 MT IX Code FUTGMO 4505 MT GBK Code FUGMO 4505 MT MBK	Stainless steel Black Glass Matte Black Metal
FEATURES	
Interiors: enamelled / other	Stainless steel
Capacity (litres)	34 L
Forced cooling	•
Functions no.	3
PERFORMANCE	
Max cooking temperature	230 °C
Grill power (W)	1500 W
Microwave power (W)	900 W
Microwave power levels	6
Cooking with Grill	•
CONTROLS	
Control type	Digital timer + Knobs
Auto power off	•
SAFETY	
Safe door / no. of glass panes	• / 3
ACCESSORIES	
Flat grill racks no.	1
Round grill rack / Glass turntable plate	• / •
POWER RATING	
Max electrical power (W)	3200 W
Voltage / Frequency (V - Hz)	220 - 240 V; 50 Hz
Power cord / Plug	• / Schuko
DIMENSIONS	
Dim. Product (W x H x D) mm	594 x 452 x 562
Built-In Cut Out (W x H x D) mm	560 x 450 x 560

# PLANO IN GRANDE

PIRO MULTIFUNCTION OVEN 30



FCPO 315 P TEM 2F ...	
Type	Electronic pyrolytic multifunction
Finish	Stainless Steel <b>X</b> Black Glass <b>BK</b>
Interiors: enamelled / other	Ultra Black Piro / -
<b>FEATURES</b>	
Efficiency class	A
Capacity (litres)	125 L
Forced cooling	•
Functions no.	18
<b>PERFORMANCE</b>	
Max cooking temperature	290 °C
Pizza Pizzeria 350°C	350 °C
AirFry (oven-frying)	•
Pyrolysis temperature	460°C
Interior dual convection	•
Assisted cleaning (CLEAN)	-
Pyrolysis	•
<b>CONTROLS</b>	
Operating system	Creactive Extended
Pre-loaded and editable recipes	•
Auto power off	•
Booster	•
Meat probe	•
<b>SAFETY</b>	
Door lock (during pyrolysis)	•
Cool-touch door / no. of glass panes	• / 4
SOFT-CLOSING DOOR	-
<b>ACCESSORIES</b>	
Lighting (Halogen, 25 W) no.	3
Set of telescopic rails no.	2
Trays no. / type	1 / enamelled
Enamelled AirFry trays no.	1
Flat racks no.	1
Side racks	-
Round pizza rack	•
Pizza Stone	•
Pizza shovel	•
Rotisserie kit	-
<b>POWER RATING</b>	
Max electrical power (W)	3650 W
Voltage / Frequency (V - Hz)	220 - 240 V; 50 - 60 Hz
Power cord	•
Plug	-
<b>DIMENSIONS</b>	
Width (mm)	754
Height (mm)	707
Depth (mm)	610
Built-In Cut Out (W x H x D) mm	722 x 696 x 610

# PLANO IN GRANDE

30" OVENS



Type	FC30 310 TEM X		FC30 310 TEM X	
	Combined Steam		Combined Microwave	
Finish / Temperature regulation	Stainless Steel <b>X</b> Black Glass <b>BK</b>	Stainless Steel <b>X</b> Black Glass <b>BK</b>	Stainless Steel <b>X</b> Black Glass <b>BK</b>	Stainless Steel <b>X</b> Black Glass <b>BK</b>
<b>FUNCTIONS</b>				
Microwave / Steam cooking	- / •	- / •	• / -	• / -
AirFry (oven-frying)	•	•	•	•
Steam heating	•	•	-	-
Microwave / steam convection oven	- / •	- / •	• / -	• / -
Steam cleaning / circuit	•	•	-	-
Puff function	•	•	-	-
Convection bake	•	•	•	•
Convection roast	•	•	•	•
Grilling	•	•	•	•
Eco Convection bake	•	•	-	-
Recipes	•	•	•	•
Oven lights	•	•	•	•
<b>CONTROL PANEL</b>				
Operating system	Creactive Extended		Creactive Extended	
Display	TFT 3.5"		TFT 3.5"	
Recipe menu	•		•	
Controls / Languages	Double Full Touch Display / 15		Double Full Touch Display / 15	
<b>FEATURES</b>				
Manual quick pre-heating	-	-	-	-
Meat probe	•	•	-	-
Cool-touch door	•	•	•	•
<b>OVEN CAPACITY</b>				
Gross capacity (litres)	34 L		34 L	
Interiors:	Stainless steel		Stainless steel	
Rack position	3		3	
Lighting (Halogen, 25 W) no.	1		1	
Upper heating element for grilling	1500 W		1500 W	
Steam generator / microwave	800 W		900 W	
Lower heating element power	300 W		-	
Convection element power	1500 W		1500 W	
<b>ACCESSORIES</b>				
Removable Water Tank	•	•	-	-
S.Steel Gastronorm Tray	•	•	•	•
Standard Flat Grill Rack / removable no.	1 / 1		1 / -	
S.Steel Perforated Tray with Lid	•	•	-	-
Glass turntable plate	-	-	•	•
Round Grill Rack	-	-	•	•
<b>POWER RATING</b>				
Max oven electrical power (W)	3200 W		3200 W	
Voltage / Frequency (V - Hz)	220 - 240V; 50 Hz		220 - 240 V; 50 Hz	
Cord / Plug	• / Schuko		• / Schuko	
<b>DIMENSIONS</b>				
Dim. Product (W x H x D) mm	754 x 474 x 564		754 x 474 x 564	
Built-In Cut Out (W x H x D) mm	722 x 463 x 560 *		722 x 463 x 560 *	

# PLANO

MULTIFUNCTION OVEN 90



FCO 9615 TEM 2F ...	
Type	Electronic multifunction
Finish	Stainless Steel <b>X</b> Black Glass <b>BK</b>
Interiors: enamelled / other	Ultra Black Piro / -
<b>FEATURES</b>	
Efficiency class	A +
Capacity (litres)	100 L
Forced cooling	•
Functions no.	16
<b>PERFORMANCE</b>	
Max cooking temperature	250 °C
Interior dual convection	•
Assisted cleaning (CLEAN)	•
<b>CONTROLS</b>	
Operating system	Creactive Extended
AirFry (oven-frying)	•
Pre-loaded and editable recipes	•
Auto power off	•
Booster	•
Meat probe	•
<b>SAFETY</b>	
Door lock	-
Cool-touch door / no. of glass panes	• / 3
SOFT-CLOSING DOOR	•
<b>ACCESSORIES</b>	
Lighting (Halogen, 25 W) no.	2
Set of telescopic rails no.	2
Trays no. / type	1 / enamelled
Enamelled AirFry trays no.	1
Flat racks no.	1
Rotisserie kit	•
<b>POWER RATING</b>	
Max electrical power (W)	3500 W
Voltage / Frequency (V - Hz)	220 - 240 V; 50 - 60 Hz
Power cord	•
Plug	Schuko
<b>DIMENSIONS</b>	
Width (mm)	894
Height (mm)	588
Depth (mm)	564
Built-In Cut Out (W x H x D) mm	860 x 585 x 560

# PLANO

MULTIFUNCTION OVEN 90X48



FCO 9013 TM ...	
Type	Electronic multifunction
Finish	Stainless Steel <b>X</b> Black Glass <b>BK/2</b>
Interiors: enamelled / other	Ultra Black Piro / -
<b>FEATURES</b>	
Efficiency class	A +
Capacity (litres)	89 L
Forced cooling	•
Functions no.	16
<b>PERFORMANCE</b>	
Max cooking temperature	250 °C
Interior dual convection	-
Assisted cleaning (CLEAN)	•
<b>CONTROLS</b>	
Operating system	Creactive
AirFry (oven-frying)	•
Pre-loaded and editable recipes	•
Auto power off	•
Booster	•
Meat probe	•
<b>SAFETY</b>	
Door lock	-
Cool-touch door / no. of glass panes	• / 3
SOFT-CLOSING DOOR	•
<b>ACCESSORIES</b>	
Lighting (Halogen, 25 W) no.	2
Set of telescopic rails no.	2
Trays no. / type	1 / enamelled
Enamelled AirFry trays no.	1
Flat racks no.	1
Rotisserie kit	•
<b>POWER RATING</b>	
Max electrical power (W)	3500 W
Voltage / Frequency (V - Hz)	220 - 240 V; 50 - 60 Hz
Power cord	•
Plug	Schuko
<b>DIMENSIONS</b>	
Width (mm)	894
Height (mm)	478
Depth (mm)	559
Built-In Cut Out (W x H x D) mm	860 x 475 x 560

# PLANO

PIRO MULTIFUNCTION OVEN 75



FCPO 7515 P TEM ...	
Type	Electronic pyrolytic multi
Finish	Stainless steel <b>X</b> Black Glass <b>BK</b>
<b>FEATURES</b>	
Interiors: enamelled	Ultra Black Pyro
Efficiency class	A +
Capacity (litres)	89 L
Forced cooling	•
Functions no.	18
<b>PERFORMANCE</b>	
Max cooking temperature	250°C
Pizza Pizzeria function	350°C
AirFry (oven-frying)	•
Pyrolysis temperature	470°C
Pyrolytic	•
<b>CONTROLS</b>	
Operating system	Creactive Extended
Pre-loaded and editable recipes	•
Auto power off	•
Booster	•
Meat probe	•
<b>SAFETY</b>	
Door lock (during pyrolysis)	•
Cool-touch door / no. of glass panes	• / 4
Soft Closing	•
<b>ACCESSORIES</b>	
Lighting (Halogen, 20 W) no.	2
Set of telescopic rails no.	2
Trays no. / type	1 / enamelled
Enamelled AirFry trays no.	1
Flat racks no.	1
Round pizza rack	•
Pizza Stone	•
Pizza shove	•
<b>POWER RATING</b>	
Max electrical power (W)	3500 W
Voltage / Frequency (V - Hz)	220 - 240 V ; 50 - 60 Hz
Power cord	•
Plug	Schuko
<b>DIMENSIONS</b>	
Width (mm)	745
Height (mm)	591
Depth (mm)	567
Built-In Cut Out (W x H x D) mm	710 x 590 x 560

# PLANO

MULTIFUNCTION OVEN 75



FCO 7515 TEM ...	
Type	Electronic multifunction
Finish	Stainless Steel <b>X</b> Black Glass <b>BK</b>
Interiors: enamelled / other	Ultra Black Piro / -
<b>FEATURES</b>	
Efficiency class	A +
Capacity (litres)	89 L
Forced cooling	•
Functions no.	16
<b>PERFORMANCE</b>	
Max cooking temperature	250 °C
AirFry (oven-frying)	•
Assisted cleaning (CLEAN) / Pyrolysis	• / -
<b>CONTROLS</b>	
Operating system	Creactive Extended
Pre-loaded and editable recipes	•
Auto power off	•
Booster	•
Meat probe	•
<b>SAFETY</b>	
Cool-touch door / no. of glass panes	• / 3
SOFT CLOSING door	•
<b>ACCESSORIES</b>	
Lighting (Halogen, 25 W) no.	2
Set of telescopic rails no.	2
Trays no. / type	1 / enamelled
Enamelled AirFry trays no.	1
Flat racks no.	1
Rotisserie kit	•
<b>POWER RATING</b>	
Max electrical power (W)	3500 W
Voltage / Frequency (V - Hz)	220 - 240 V; 50 - 60 Hz
Power cord	•
Plug	Schuko
<b>DIMENSIONS</b>	
Width (mm)	745
Height (mm)	589
Depth (mm)	564
Built-In Cut Out (W x H x D) mm	710 x 585 x 560

# PLANO

STEAM OVEN 75X45



FCSO 7510 TEM ...	
Type	Combined Steam
Finish	Stainless Steel <b>X</b> Black Glass <b>BK</b>
Interiors: enamelled / other	Stainless steel
<b>FEATURES</b>	
Efficiency class	A ++
Capacity (litres)	34 L
Forced cooling / Meat probe	• / •
Functions no.	11
<b>PERFORMANCE</b>	
Max cooking temperature	230 °C
AirFry (oven-frying)	•
Pre-loaded and editable recipes	•
Steam100 °C / 130 °C	• / •
Steam puff 100 °C	•
Steam + Thermoventilated	•
Assisted cleaning (CLEAN)	•
Grill power (W)	1500 W
<b>CONTROLS</b>	
Operating system	Creactive Extended
Easy access / Auto power off	• / •
<b>SAFETY</b>	
Safe door / no. of glass panes	• / 3
Safety switch	•
<b>ACCESSORIES</b>	
Lighting (Halogen, 25 W) no.	1
Removable water tank	•
S.Steel Gastronorm Tray	•
Standard Flat Grill Rack / removable no.	1 / 1
S.Steel Perforated Tray with Lid	•
<b>POWER RATING</b>	
Max electrical power (W)	3200 W
Voltage / Frequency (V - Hz)	220 - 240 V; 50 Hz
Power cord / Plug	• / Schuko
<b>DIMENSIONS</b>	
Width (mm)	745
Height (mm)	452
Depth (mm)	562
Built-In Cut Out (W x H x D) mm	710 x 450 x 560

# PLANO

MICROWAVE OVEN 75X45



FCMO 7510 TEM...	
Type	Combined Microwave
Finish	Stainless Steel <b>X</b> Black Glass <b>BK</b>
Interiors: enamelled / other	Stainless steel
<b>FEATURES</b>	
Capacity (litres)	34 L
Forced cooling	•
Functions no.	10
<b>PERFORMANCE</b>	
Max cooking temperature	230 °C
AirFry (oven-frying)	•
Pre-loaded and editable recipes	•
Defrosting (time/weight)	•
Microwave with grill	• / •
Microwave + Convection	•
Microwave power (W)	900 W
Microwave power levels	6
Grill power (W)	1500 W
<b>CONTROLS</b>	
Operating system	Creactive Extended
Auto power off	•
<b>SAFETY</b>	
Door with safety switch	•
Safe door / no. of glass panes	• / 3
Panel lock	•
<b>ACCESSORIES</b>	
Lighting (Halogen, 25 W) no.	1
S.Steel Gastronorm Tray	•
Standard Flat Grill Rack / removable no.	1 / -
Glass turntable plate / Round Grill Rack	• / •
<b>POWER RATING</b>	
Max electrical power (W)	3200 W
Voltage / Frequency (V - Hz)	220 - 240 V; 50 Hz
Power cord / Plug	• / Schuko
<b>DIMENSIONS</b>	
Width (mm)	745
Height (mm)	452
Depth (mm)	562
Built-In Cut Out (W x H x D) mm	710 x 450 x 560

# PLANO

ATMOS STEAM OVEN 60



FCSO 6023 TEM...		
Type	Combined Steam	
Dimension	60	
Structure - Finish	Stainless steel <b>X</b> Black Glass <b>BK</b>	
Temperature regulation	Electronic	
<b>FEATURES</b>		
Efficiency class	A++	
Capacity (litres)	65	
Forced cooling	•	
Meat probe	•	
Sizes	Timer 12 / 24 - Temperature °C / °F - Weight Kg / lb	
Cooking functions	Classic 11	Steam 6 Special 7
Max cooking temperature	250 °C	
Grill power (W)	1200 + 1000	
Steam cooking autonomy	> 3 hours	
Water tank capacity	1.5 l (Topping up without door opening)	
Dashboard opening - touch control	•	
<b>FUNCTIONS</b>		
	Classic Pizza function at 250 °C	AirFry (oven-frying)
	Steam cooking from 30 ° to 100°C	Pre-loaded and editable recipes
	Puff function	Low-temperature cooking
	Sous vide	Defrost function with steam
	Leavening function	Regeneration (180 °C)
<b>CONTROL PANEL</b>		
Display   Control type	TFT 3.5"   MODULAR - Electronic (double full touch keypad)	
Fast recipe selection	•	
Languages	15	
<b>FEATURES</b>		
	Demo Mode	Steam cleaning function
	Beep volume setting	Circuit cleaning function
	Display brightness setting	Sabbath mode
	Descaling function	Event logs (for assistance)
<b>OVEN DOOR</b>		
Cool touch - no. of glass panes	3	
Closure	soft closed	
<b>ACCESSORIES</b>		
Side rack levels	5 (removable side racks)	
Rectangular halogen light (25 W)	2	
Fully removable telescopic rails	1 pair	
S. Steel Gastronorm perforated trays	1	
AirFry enamel tray	1	
Gastronorm flat tray	1	
Tray support frame	1	
Enamelled trays	1	
Flat racks	1	
<b>DIMENSIONS</b>		
Product (W x H x D) mm	594 x 596 x 560	
Built-In Cut Out (W x H x D) mm	560 x 585 x 560	
<b>ELECTRICAL FEATURES</b>		
Max electrical power	3.50 kW	
Voltage / Frequency (V - Hz)	220 - 240 V; 50 Hz	
Power cord	•	
Plug	Schuko	

# PLANO

PIRO MULTIFUNCTION OVEN 60



FCPO 6215 P TEM ...	
Type	Electronic pyrolytic multifunction
Finish	Stainless Steel <b>X</b>
	Black Glass <b>BK</b>
	White Glass <b>WH</b>
Interiors: enamelled / other	Ultra Black Piro / -
<b>FEATURES</b>	
Efficiency class	A +
Capacity (litres)	65 L
Forced cooling	•
Functions no.	18
<b>PERFORMANCE</b>	
Max cooking temperature	290 °C
Pizza Pizzeria 350 °C function	350 °C
AirFry (oven-frying)	•
Pyrolysis temperature	470 °C
Pyrolytic	•
<b>CONTROLS</b>	
Operating system	Creactive Extended
Pre-loaded and editable recipes	•
Auto power off	•
Booster	•
Meat probe	•
<b>SAFETY</b>	
Door lock (during pyrolysis)	•
Cool-touch door / no. of glass panes	• / 4
SOFT CLOSING door	•
<b>ACCESSORIES</b>	
Lighting (Halogen, 25 W) no.	2
Set of telescopic rails no.	2
Trays no. / type	1 / enamelled
Enamelled AirFry trays no.	1
Flat racks no.	1
Round pizza rack	•
Pizza Stone	•
Pizza shovel	•
<b>POWER RATING</b>	
Max electrical power (W)	3450 W
Voltage / Frequency (V - Hz)	220 - 40 / 50 - 60 Hz
Power cord	•
Plug	Schuko
<b>DIMENSIONS</b>	
Width (mm)	594
Height (mm)	596
Depth (mm)	560
Built-In Cut Out (W x H x D) mm	560 x 585 x 560

# PLANO

MULTIFUNCTION OVEN 60



FCOS 6215 TEM X	
Type / Finish	Electronic multifunction / Stainless steel
Interiors: enamelled / other	Ultra Black Piro / -
<b>FEATURES</b>	
Efficiency class	A ++
Capacity (litres)	65 L
Forced cooling	•
Functions no.	16
<b>PERFORMANCE</b>	
Max cooking temperature	250 °C
Assisted cleaning (CLEAN)	•
<b>CONTROLS</b>	
Operating system	Creactive Extended
AirFry (oven-frying)	•
Pre-loaded and editable recipes	•
Auto power off / Booster	• / •
Meat probe	•
<b>SAFETY</b>	
Cool-touch door / no. of glass panes	• / 3
Door with Side opening	•
<b>ACCESSORIES</b>	
Lighting (Halogen, 25 W) no.	2
Set of telescopic rails no.	2
Trays no. / type	1 / enamelled
Enamelled Airfry trays / Flat racks no.	1 / 1
<b>POWER RATING</b>	
Max electrical power (W)	3500W
Voltage / Frequency (V - Hz)	220 - 240 V; 50 - 60 Hz
Power cord / Plug	• / Schuko
<b>DIMENSIONS</b>	
Width (mm)	594
Height (mm)	596
Depth (mm)	560
Built-In Cut Out (W x H x D) mm	560 x 585 x 560

# PLANO

MULTIFUNCTION OVEN 60



FCO 6215 TEM...	
Type / Finish	Electronic multifunction
Finish	Stainless Steel <b>X</b>
	Black Glass <b>BK</b>
	White Glass <b>WH</b>
Interiors: enamelled / other	Ultra Black Piro / -
<b>FEATURES</b>	
Efficiency class	A ++
Capacity (litres) / Functions n	65 L / 16
Forced cooling	•
<b>PERFORMANCE</b>	
Max cooking temperature	250 °C
Assisted cleaning (CLEAN)	•
<b>CONTROLS</b>	
Operating system	Creactive Extended
AirFry (oven-frying)	•
Pre-loaded and editable recipes	•
Auto power off / Booster	• / •
Meat probe	•
<b>SAFETY</b>	
Cool-touch door / no. of glass panes	• / 3
Soft Closing	•
<b>ACCESSORIES</b>	
Lighting (Halogen, 25 W) no.	2
Set of telescopic rails no.	2
Trays no. / type	1 / enamelled
Enamelled Airfry trays / Flat racks no.	1 / 1
<b>POWER RATING</b>	
Max electrical power (W)	3500W
Voltage / Frequency (V - Hz)	220 - 240 V; 50 - 60 Hz
Power cord / Plug	• / Schuko
<b>DIMENSIONS</b>	
Width (mm)	594
Height (mm)	596
Depth (mm)	560
Built-In Cut Out (W x H x D) mm	560 x 585 x 560

# PLANO

STEAM OVEN 45



FCSO 4510 TEM ...	
Type	Combined Steam
Finish	Stainless Steel <b>X</b>
	Black Glass <b>BK</b>
	White Glass <b>WH</b>
Interiors: enamelled / other	Stainless steel
<b>FEATURES</b>	
Efficiency class	A ++
Capacity (litres)	34 L
Forced cooling / Meat probe	• / •
Functions no.	11
<b>PERFORMANCE</b>	
Max cooking temperature	230 °C
AirFry (oven-frying)	•
Pre-loaded and editable recipes	•
Steam100 °C / 130 °C	• / •
Puff function	•
Steam + Thermoventilated	•
Assisted cleaning (CLEAN)	•
Grill power (W)	1500 W
<b>CONTROLS</b>	
Operating system	Creactive Extended
Easy access / Auto power off	• / •
<b>SAFETY</b>	
Safe door / no. of glass panes	• / 3
Safety switch	•
<b>ACCESSORIES</b>	
Lighting (Halogen, 25 W) no.	1
Removable Water Tank	•
S.Steel Gastronorm Tray	•
Standard Flat Grill Rack / removable no.	1 / 1
S.Steel Perforated Tray with Lid	•
<b>POWER RATING</b>	
Max electrical power (W)	3200 W
Voltage / Frequency (V - Hz)	220 - 240 V; 50 Hz
Power cord / Plug	• / Schuko
<b>DIMENSIONS</b>	
Width (mm)	594
Height (mm)	452
Depth (mm)	556
Built-In Cut Out (W x H x D) mm	560 x 450 x 560

# PLANO

MICROWAVE OVEN 45



FCMO 4510 TEM ...	
Type	Combined Microwave
Finish	Stainless Steel <b>X</b>
	Black Glass <b>BK</b>
	White Glass <b>WH</b>
Interiors: enamelled / other	Stainless steel
<b>FEATURES</b>	
Capacity (litres)	34 L
Forced cooling	•
Functions no.	10
<b>PERFORMANCE</b>	
Max cooking temperature	230 °C
AirFry (oven-frying)	•
Pre-loaded and editable recipes	•
Defrosting (time/weight)	•
Microwave with grill	• / •
Microwave + Convection	•
Microwave power (W)	900 W
Microwave power levels	6
Grill power (W)	1500 W
<b>CONTROLS</b>	
Operating system / Auto power off	Creactive Extended / •
<b>SAFETY</b>	
Door with safety switch	•
Safe door / no. of glass panes	• / 3
Panel lock	•
<b>ACCESSORIES</b>	
Lighting (Halogen, 25 W) no.	1
S.Steel Gastronorm Tray	•
Standard Flat Grill Rack / removable no.	1 / -
Glass turntable plate	•
Round Grill Rack	•
<b>POWER RATING</b>	
Max electrical power (W)	3200 W
Voltage / Frequency (V - Hz)	220 - 240 V; 50 Hz
Power cord / Plug	• / Schuko
<b>DIMENSIONS</b>	
Width (mm)	594
Height (mm)	452
Depth (mm)	562
Built-In Cut Out (W x H x D) mm	560 x 450 x 560

# PLANO

MICROWAVE AND GRILL OVEN 45



FGMO 4508 TEM ...	
Type	Microwave with grill
Finish	Stainless Steel <b>X</b>
	Black Glass <b>BK</b>
	White Glass <b>WH</b>
Interiors: enamelled / other	Stainless steel
<b>FEATURES</b>	
Capacity (litres)	34 L
Forced cooling	•
Functions no.	5
<b>PERFORMANCE</b>	
Max cooking temperature	230 °C
Pre-loaded and editable recipes	•
Defrosting (time/weight)	•
Microwave with grill	• / •
Microwave + Convection	-
Microwave power (W)	900 W
Microwave power levels	6
Grill power (W)	1500 W
<b>CONTROLS</b>	
Operating system	Creactive Extended
Auto power off	•
<b>SAFETY</b>	
Door with safety switch	•
Safe door / no. of glass panes	• / 3
Panel lock	•
<b>ACCESSORIES</b>	
Lighting (Halogen, 25 W) no.	1
S.Steel Gastronorm Tray	•
Standard Flat Grill Rack / removable no.	1 / -
Glass turntable plate	•
Round Grill Rack	•
<b>POWER RATING</b>	
Max electrical power (W)	3200 W
Voltage / Frequency (V - Hz)	220 - 240 V; 50 Hz
Power cord / Plug	• / Schuko
<b>DIMENSIONS</b>	
Width (mm)	594
Height (mm)	452
Depth (mm)	562
Built-In Cut Out (W x H x D) mm	560 x 450 x 560

# PLANO

BLAST CHILLER 45



FBC 4500 TF ...	
Type	Blast chiller multifunction
Finish	Stainless Steel <b>X</b>
	Black Glass <b>BK</b>
	White Glass <b>WH</b>
Interiors: enamelled / other	Stainless steel
<b>FEATURES</b>	
Volume (litres)	40 L
Total functions no.	11
Cold functions	7
Hot functions	4
Meat probe	•
<b>PERFORMANCE</b>	
Sanitation - 30°C	•
Blast chilling up to + 3°C	•
Deep-freezing up to 18 °C	•
Timed cooling	•
Bottle cooling	•
Low-temperature cooking up to +75 °C	•
Regeneration	•
Ready to serve	•
<b>CONTROLS</b>	
Programming	TFT Display
Auto power off	•
<b>SAFETY</b>	
Temperature overload protection sensors	•
Control lock	•
<b>ACCESSORIES</b>	
Lighting (Halogen, 25 W) no.	1
Flat racks / glass tray no.	1 / 1
<b>POWER RATING</b>	
Max electrical power (W)	300 W
Voltage / Frequency (V - Hz)	230 - 50
Power cord	•
Plug	Schuko
<b>DIMENSIONS</b>	
Width (mm)	594
Height (mm)	452
Depth (mm)	571
Built-In Cut Out (W x H x D) mm	560 x 450 x 560

# WINE CELLAR 45

PLANO - URBANTECH - URBANTECH TOUCH - CLUSTER



Type	Wine cellar	
Finish	Built-In	
Bottle no. (Ø 76 mm)	22	
Code FCLWC 4500 TC FO BK Code FUTWC 4500 TC FO MBK Code FUTWC 4500 TC FO IX Code FUWC 4500 TC FO MBK Code FUWC 4500 TC FO IX Code FWC 4500 TC FO X Code FWC 4500 TC FO BK Code FWC 4500 TC FO WH	Cluster collection Urbantech Touch collection Urbantech Touch collection Urbantech collection Urbantech collection Plano collection Plano collection Plano collection	Deep Black Glass finish Matte Black Metal finish Stainless steel finish Matte Black Metal finish Stainless steel finish Stainless steel finish Black Glass finish White Glass finish
Drop-down door	•	
<b>PERFORMANCE</b>		
Cooling system	Ventilated	
Temperature zones	1	
Adjustable temperature (°C)	from 5 to 20	
Efficiency class	G	
Anti-vibration system	•	
Anti-condensation system	•	
Climate class	SN-T	
Sound level dB (A) re1pW	39	
<b>CONTROL SYSTEM</b>		
	Electronic regulation	Digital touch display
	Double automatic hot/cold circuit	Control light indicator
<b>ACCESSORIES</b>		
UV-insulating glass pane	•	
Lighting	LED	
Sliding wooden shelves / type	3 / Beech	
Champagne shelf (4 bottles)	1	
<b>POWER RATING</b>		
Max power absorbed at 220 V	80W	
Power supply (V - Hz)	220-240 / 50	
Plug (Schuko)	•	
<b>DIMENSIONS</b>		
Product (W x H x D) mm	594 x 452 x 556	
Built-In Cut Out (W x H x D) mm	450 x 560 x 560	

# COFFEE MACHINE 45

PLANO - URBANTECH - URBANTECH TOUCH - CLUSTER



Type	Coffee machine	
Code FCM 4500 TF BK + F6PTK30BC Code FCLCM 4500 TF BK Code FUCM 4500 TF MBK Code FUCM 4500 TF IX Code FCM 4500 TF X Code FCM 4500 TF BK Code FCM 4500 TF WH	Professional collection Cluster collection Urbantech Touch collection Urbantech Touch collection Urbantech collection Urbantech collection Plano collection Plano collection Plano collection	Stainless steel finish Black Glass finish Matte Black Metal finish Stainless steel finish Matte Black Metal finish Stainless steel finish Stainless steel finish Black Glass finish White Glass finish
<b>PERFORMANCE</b>		
Total functions no. / Operating system	30 / Full Touch TFT	
Automatic functions	Coffee, steam, hot water	
Energy efficiency	A	
Annual energy consumption (kWh)	45	
Water / coffee container capacity	1.8 L / 200 g	
Coffee grinder with 13 regulation levels	•	
Coffee cups no.	2	
	Height-adjustable (80-100 mm) coffee dispenser	Retractable dispenser for steam and hot water
	Compartment LED lighting	Automatic descaling program
Integrated cleaning program	•	
Milk container (0.75 l)	•	
Drip tray	•	
Anti-scale filter indicator / water indicator	• / •	
Residual emptying indicator	•	
Telescopic rails	•	
<b>POWER RATING</b>		
Max electrical power (W)	1350 W	
Voltage / Frequency (V - Hz)	220 - 240 V; 50 - 60 Hz	
Power cord / Plug	• / Schuko	
Pump pressure (bar)	15	
<b>DIMENSIONS</b>		
Product (W x H x D) mm	594 x 455 x 443	
Built-In Cut Out (W x H x D) mm	560 x 450 x 560	
Professional Product (W x H x D) mm	758 x 476 x 476	
Pro Built-In Cut Out (W x H x D) mm	722 x 463 x 610	



## DRAWERS

VACUUM SEALING DRAWER 15



	FVSD 150 TC X	FVSD 150 TC BK	FVSD 150 TC WH	FCLVSD 150 TC BK	FUTVSD 150 TC MBK
Front finish	Stainless steel	Black Glass	White Glass	Deep Black Glass	Matte Black Metal
Type / Interiors: enamelled / other	Vacuum sealing drawer / Stainless steel				
<b>CARATTERISTICHE</b>					
	Push-to-open system		Programming Touch controls   4 total functions		
	Max vacuum level 2 - 10 mbar (99.9%)		Container volume 6.4 l Max bag size 25 x 35 cm		
	Chamber height 95 mm   65° degrees lid opening		Removable sealing bar (length 260 mm)		
	CHEF cycle		Cooking cycle duration: 55"		
	3 storage cycles  duration 70"		Vacuum cycle in container		
	Oil overheating warning light		Oil de-humidification cycle		
<b>POWER RATING</b>					
	Max electrical power 230 W		Voltage / Frequency (V - Hz) 230 - 50 / 60		
	Power cord		Plug (Schuko)		
<b>DIMENSIONS</b>					
	Product (W x H x D) 594 x 140 x 568 mm		Built-In Cut Out (W x H x D) 560 x 142 x 560 mm		

## DRAWERS

VACUUM SEALING DRAWER 29



	FVSD 2900 TC	
Type / Interiors: enamelled / other	Vacuum sealing drawer / Stainless steel	
<b>FEATURES</b>		
	Push-to-open system	Programming Touch controls   4 total functions
	Max vacuum level 2 - 10 mbar (99.9%)	Container volume 7.65 l
	Chamber height 110 mm   65° degrees lid opening	Removable sealing bar (length 260 mm)
	Cooking cycle duration: 55"	3 storage cycles  duration 70"
	Vacuum cycle in container	Max bag size 25 x 35 cm
	Oil overheating warning light	Oil de-humidification cycle
<b>POWER RATING</b>		
	Max electrical power 350 W	Voltage / Frequency (V - Hz) 230 - 50 / 60
	Power cord	Plug (Schuko)
<b>DIMENSIONS</b>		
Product (W x H x D) mm	Product (W x H x D) 594 x 294 x 552 mm	Built-In Cut Out (W x H x D) 560 x 290 x 560 mm

## DRAWERS

WARMING DRAWER 15



	FWD 150 X	FWD 150 BK	FWD 150 WH	FCLWD 150 BK	FUWD 150 MBK
Finish	Stainless Steel	Black Glass	White Glass	Deep Black Glass	Matte Black Metal
Type / Interiors: enamelled / other	Warming drawer / Anti-slip rubber bottom				
<b>PERFORMANCE</b>					
	Maximum temperature 70 °C		Low-temperature cooking (slow cooking)		
	Leavening		Plates and dish heating		
<b>CONTROLS</b>					
	On/off key		Thermostat 30 °C - 70 °C		
	Internal ventilation		Operation indicator		
	Push-to-open door		Dark front panel		
<b>POWER RATING</b>					
	Max power absorbed 400 W		Power supply (V - Hz) 220 - 240 V; 50-60 Hz		
	Power cord		Plug (Schuko)		
<b>DIMENSIONS</b>					
	Product (W x H x D) 594 x 145 x 562 mm		Built-In Cut Out (W x H x D) 560 x 142 x 560 mm		

## DRAWERS

WARMING DRAWER 27

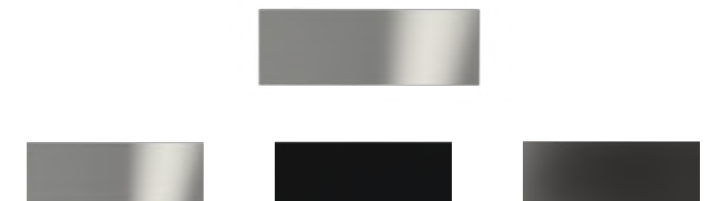

	FWD 3024 X	FWD 3024 BK	FWD 3024 MBK
Type: warming drawer / Stainless Steel finish			Anti-slip rubber bottom
Push-to-open door			It can be combined with oven mod.
<b>PERFORMANCE</b>			
	Maximum temperature 85 °C		Low-temperature cooking (slow cooking)
	Leavening		Warm food function
<b>CONTROLS</b>			
	On/off key		Thermostat 30 °C - 85 °C
	Internal ventilation   Operation indicator		Dark front panel
<b>POWER RATING</b>			
	Max power absorbed 1100 W		Power supply (V - Hz) 220 - 240 V; 50 - 60 Hz
	Power cord		Plug (Schuko)
<b>DIMENSIONS</b>			
Product (W x H x D) mm	Product (W x H x D) 754 x 264 x 603 mm	Built-In Cut Out (W x H x D) 722 x 235 x 610 mm	

NEW

## DRAWERS

WARMING DRAWER 27

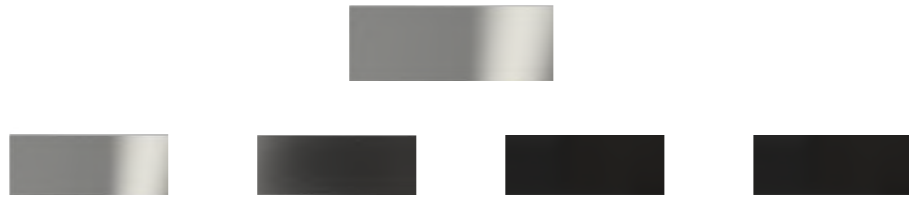

	FUTWD 7527 IX	FUTWD 7527 MBK	FUTWD 7527 GBK	FCLWD 7527 BK
Finish	Stainless Steel	Matte Black Metal	Black Glass	Deep Black Glass
Type	Type: warming drawer / Stainless Steel		Anti-slip rubber bottom	
Push-to-open door			Compatible with all 745 mm ovens	
<b>PERFORMANCE</b>				
Maximum temperature	85 °C		Low-temperature cooking (slow cooking)	
Leavening			Warm food function	
<b>CONTROLS</b>				
On/off key			Thermostat 30 °C - 85 °C	
Internal ventilation   Operation indicator			Dark front panel	
<b>POWER RATING</b>				
Max power absorbed	1100 W		Power supply (V - Hz) 220 - 240 V; 50 - 60 Hz	
Power cord			Plug (Schuko)	
<b>DIMENSIONS</b>				
Product (W x H x D) mm	Product (W x H x D) 754 x 264 x 576 mm		Built-In Cut Out (W x H x D) 710 x 235 x 560 mm	

## DRAWERS

STORAGE DRAWER 15



	FD 150 X	FD 150 BK	FD 150 WH	FCLD 150 BK	FUD 150 MBK
Finish	Stainless Steel	Black Glass	White Glass	Deep Black Glass	Matte Black Metal
Type	Type: storage drawer		Anti-slip rubber bottom		
Push-to-open door			•		
<b>DIMENSIONS</b>					
Product (W x H x D) mm	Product (W x H x D) 594 x 145 x 562 mm		Built-In Cut Out (W x H x D) 560 x 142 x 560 mm		

## INDUCTION HOBS

GLASS-CERAMIC INDUCTION HOBS



	FHH 600 ID TC BK	FHH 800 ID TC BK	
Dimension	60	80	
Technology	Induction B4	Induction B4	
Type of glass	Black Glass Ceramic	Black Glass Ceramic	
Control type	Touch	Touch	
Version	with extraction hood	with extraction hood	
Efficiency class	A ++	A ++	
<b>INDUCTION HOB TECHNICAL DATA</b>			
Power limiter	•	•	
Power levels	9 + P	9 + P	
Booster	5 minutes	5 minutes	
Controls	Multifunction Touch Control	M Multifunction Touch Control	
Power level indication slider	•	•	
Residual heat indicator for each zone	•	•	
<b>FUNCTIONS</b>			
"Pause and Resume" function	Pan detector	"Pause and Resume" function	Pan detector
Overheating prot. device	Tem. lock Controls	Overheating prot. device	Tem. lock Controls
Children lock	Operation timer	Children lock	Operation timer
Melt function (44 °C)	Aut. fast heating	Melt function (44 °C)	Aut. fast heating
Single zone timer	Chef function	Aut. fast heating	Chef function
Buzzer	Bridge function	Buzzer	Bridge function
<b>4 ZONES</b>			
Zone Dimension	220 X 190 mm	220 X 190 mm	
Bridge function	2 vertical bridge zones	2 vertical bridge zones	
Max zone power (L9)	2100W	2100W	
Booster zone power	3000W	3000W	
<b>HOOD TECHNICAL DATA</b>			
Adjustable delayed auto power off	•	•	
Anti-grease filter maintenance indicator	•	•	
Ceramic filter regeneration LED indicator	•	•	
Internal water discharge valve	•	•	
Dishwasher-safe filter	•	•	
Regenerable ceramic odour filter removable from the top (optional)	•	•	
Automatic hood shut-off when the flap is closed	•	•	
Motor under the glass	•	•	
Patented waterproof motor	•	•	
Air exhaust plastic connection	•	•	
Maximum flow rate (m³ / h)	700	700	
Pressure (Pa)	540	540	
Motor power (W)	220	220	
Voltage (V)	220 - 240	220 - 240	
Frequency (Hz)	50 - 60	50 - 60	
Sound power max sp. dB(A)	62	62	
Controls	Multifunction Touch Control	Multifunction Touch Control	
<b>DIMENSIONS</b>			
Width x Height x Depth (mm)	600 x 250 x 520	800 x 250 x 520	
Cutout Width x Depth (mm)	560 x 480	750 x 490	
<b>PERFORMANCE</b>			
Max power absorbed (kW)	7.36	7.36	
Voltage (V)	220/240	220/240	
Frequency (Hz)	50/60	50/60	
<b>INSTRUCTION MANUAL</b>			
Use and installation manual	IT - EN - FR - DE - ES - RU	IT - EN - FR - DE - ES - RU	

# INDUCTION HOB

48" ENOVA HOB



FEHCPK 4805 ID ...				
Type	120 Induction Hob			
Aesthetic	Steel Finish Matte Black Anodized	<b>IX</b> <b>MBK</b>		
Surface	Glass Ceramic			
Knobs	Integrated			
<b>INDUCTION PERFORMANCE</b>				
Induction features	Pan Detection System	Child Lock		
Knobs for power adjustment	•			
Power levels	1-9			
Digital display indicating power level	•			
Melting function at 45°C	•			
Keep warm function at 70°C	•			
Simmering function at 95°C	•			
Booster / Rapid boil function for each zone	•			
Rapid heating	•			
Bridge function	•			
Rear Right	•			
<b>COOKING ZONE FEATURES</b>				
		Dimensions	Power	
5 Cooking Zones (2 Bridge Zones)				
1 Front Left	Octa Induction	220 x 180 mm	Level 9 - 2100W	Booster - 3700W
2 Rear Left	Octa Induction	220 x 180 mm	Level 9 - 2100W	Booster - 3700W
3 Central Dual Circuit	Round Induction	Ø 280 mm	Level 9 - 2600W	Booster - 5500W
4 Front Right	Octa Induction	220 x 180 mm	Level 9 - 2100W	Booster - 3700W
5 Posteriore Destro	Octa Induction	220 x 180 mm	Level 9 - 2100W	Booster - 3700W
<b>DIMENSIONS</b>				
Width	1199 mm			
Height (Without power cable)	66 mm			
Depth	480 mm			
Cut-out Width	1175 mm			
Cut-out Depth	462 mm			
<b>ELECTRICAL SPECIFICATIONS</b>				
Maximum Electrical Power (W)	11040W			
Conduit	•			

# INDUCTION HOB

48" ENOVA HOB



FEHK 4805 ID ...				
Type	120 Induction Hob			
Finish	Steel Finish Matte Black Anodized	<b>IX</b> <b>MBK</b>		
Surface	Glass Ceramic			
<b>INDUCTION PERFORMANCE</b>				
Induction features	Pan Detection System	Child Lock		
Knobs for power adjustment	•			
Power levels	1-9			
Digital display indicating power level	•			
Melting function at 45°C	•			
Keep warm function at 70°C	•			
Simmering function at 95°C	•			
Booster / Rapid boil function for each zone	•			
Rapid heating	•			
Bridge function	•			
Rear Right	•			
<b>COOKING ZONE FEATURES</b>				
		Dimensions	Power	
5 Cooking Zones (2 Bridge Zones)				
1 Front Left	Octa Induction	220 x 180 mm	Level 9 - 2100W	Booster - 3700W
2 Rear Left	Octa Induction	220 x 180 mm	Level 9 - 2100W	Booster - 3700W
3 Central Dual Circuit	Round Induction	Ø 280 mm	Level 9 - 2600W	Booster - 5500W
4 Front Right	Octa Induction	220 x 180 mm	Level 9 - 2100W	Booster - 3700W
5 Posteriore Destro	Octa Induction	220 x 180 mm	Level 9 - 2100W	Booster - 3700W
<b>DIMENSIONS</b>				
Width	1199 mm			
Height (Without power cable)	66 mm			
Depth	480 mm			
Cut-out Width	1175 mm			
Cut-out Depth	462 mm			
<b>ELECTRICAL SPECIFICATIONS</b>				
Maximum Electrical Power (W)	11040W			
Conduit	•			

# INDUCTION HOB

36" ENOVA HOBS



FEHCPK 3605 ID ...				
Type	90 cm Induction Hob			
Aesthetics	Steel Finish Matte Black Anodized		<b>IX</b> <b>MBK</b>	
Surface	Glass Ceramic			
Knobs	Integrated			
<b>INDUCTION PERFORMANCE</b>				
Induction features	Pan Detection System		Child Lock	
	Cooling System		Cooking Level Indicator	
Knobs for power adjustment	•			
Power levels	1-9			
Digital display indicating power level	•			
Melting function at 45°C	•			
Keep warm function at 70°C	•			
Simmering function at 95°C	•			
Booster / Rapid boil function for each zone	•			
Rapid heating	•			
Bridge function	•			
Rear Right	•			
<b>COOKING ZONE FEATURES</b>				
	Dimensions		Power	
5 Cooking Zones (2 Bridge Zones)				
1 Front Left	Octa Induction	220 x 180 mm	Level 9 - 2100W	Booster - 3700W
2 Rear Left	Octa Induction	220 x 180 mm	Level 9 - 2100W	Booster - 3700W
3 Central Dual Circuit	Round Induction	Ø 280 mm	Level 9 - 2600W	Booster - 5500W
4 Front Right	Octa Induction	220 x 180 mm	Level 9 - 2100W	Booster - 3700W
5 Posteriore Destro	Octa Induction	220 x 180 mm	Level 9 - 2100W	Booster - 3700W
<b>DIMENSIONS</b>				
Width	913 mm			
Height (Without power cable)	66 mm			
Depth	530 mm			
Cut-out Width	840 mm			
Cut-out Depth	500 mm			
<b>ELECTRICAL SPECIFICATIONS</b>				
Maximum Electrical Power (W)	11040W			
Conduit	•			

# INDUCTION HOB

36" ENOVA HOBS



FEHK 3605 ID ...				
Type	90 Induction Hob			
Aesthetic	Steel Finish Matte Black Anodized		<b>IX</b> <b>MBK</b>	
Surface	Glass Ceramic			
<b>INDUCTION PERFORMANCE</b>				
Induction features	Pan Detection System		Child Lock	
	Cooling System		Cooking Level Indicator	
Knobs for power adjustment	•			
Power levels	1-9			
Digital display indicating power level	•			
Melting function at 45°C	•			
Keep warm function at 70°C	•			
Simmering function at 95°C	•			
Booster / Rapid boil function for each zone	•			
Rapid heating	•			
Bridge function	•			
Rear Right	•			
<b>COOKING ZONE FEATURES</b>				
	Dimensions		Power	
5 Cooking Zones (2 Bridge Zones)				
1 Front Left	Octa Induction	220 x 180 mm	Level 9 - 2100W	Booster - 3700W
2 Rear Left	Octa Induction	220 x 180 mm	Level 9 - 2100W	Booster - 3700W
3 Central Dual Circuit	Round Induction	Ø 280 mm	Level 9 - 2600W	Booster - 5500W
4 Front Right	Octa Induction	220 x 180 mm	Level 9 - 2100W	Booster - 3700W
5 Posteriore Destro	Octa Induction	220 x 180 mm	Level 9 - 2100W	Booster - 3700W
<b>DIMENSIONS</b>				
Width	913 mm			
Height (Without power cable)	66 mm			
Depth	530 mm			
Cut-out Width	840 mm			
Cut-out Depth	500 mm			
<b>ELECTRICAL SPECIFICATIONS</b>				
Maximum Electrical Power (W)	11040W			
Conduit	•			

# INDUCTION HOBS

GLASS-CERAMIC INDUCTION HOBS



FCLHD 9041 HID TS BK2	
Type	ARIA + with rear extraction hood
Finish	Black Glass Ceramic
<b>INDUCTION PERFORMANCE</b>	
Octa Flexi N.   Pot. MIN / MAX	-
Octa Bridge N.   Pot. MIN / MAX	2 Horizontal   1000 / 3700 W
Max electrical power (W)	7360 W
Preloaded temperatures 42 °C (Melt)	•
70°C Slow cooking	•
90°C Simmering	•
<b>INDUCTION CONTROLS</b>	
Operating system	Touch&Slider
AUTO cooking	•
Timer	•
Residual heat detector (H)	•
Buzzer / Pan detector	• / •
Keypad lock	•
Power levels no.	9 + P
Digital display	•
<b>HOOD FEATURES</b>	
Efficiency class	A +
Extraction levels	•
Delayed auto power off	• / 10 min
Anti-grease filter saturation indicator	• / 30 h
HP filter replacement light	-
Anti-grease filter with oil-collection tray / type	-
Dishwasher-safe anti-grease filter	•
Rear air outlet size	rect. 220 x 90
Airflow non-return flap	-
HP filter for filtering version (optional)	FHCF 59
AUTO opening (2 steps)	45° - 90°
Controls	Touch
Extraction capacity up to m <sup>3</sup> / h	645 m <sup>3</sup> /h
Sound emissions (dBA)	53 - 63
Estimated annual consumption (kWh)	43.3
BRHM motor (W)	220
<b>ACCESSORIES</b>	
Scraper	-
Power cord	•
<b>DIMENSIONS</b>	
Width (mm)	898
Height (mm)	-
Depth (mm)	520
Built-In Cut Out (W x D) mm	860 x 490

# INDUCTION HOBS

GLASS-CERAMIC INDUCTION HOBS



	FSH 905 ID WT BK	FSH 804 ID WT BK
Type	5 cooking zones	4 cooking zones
Finish	Black Glass Ceramic	Black Glass Ceramic
<b>PERFORMANCE</b>		
Ø 260 DUAL	1 zone   3000 / 5500 W	1 zone   3000 / 5500 W
Octa Flexi N.   Pot. MIN / MAX	2 Flexi Vertical   2100 / 3700 W	1 Flexi Vertical   2100 / 3700 W
Ø 145	-	N.1 Zone   1400 / 2200 W
Preset temperatures 42 °C (Melt)	•	•
70°C Slow cooking	•	•
90°C Simmering	•	•
Max electrical power (W)	11040 W	7360 W
<b>FEATURES</b>		
Operating system	Wave Touch	Wave Touch
AUTO cooking	•	•
Timer	•	•
Residual heat detector (H)	•	•
Automatic pan detection sensor	•	•
Keypad lock	•	•
Power levels no.	9 + P	9 + P
Digital display	•	•
<b>ACCESSORIES</b>		
Scraper / Power cord	•	•
<b>DIMENSIONS</b>		
Width (mm)	900	800
Height (mm)	50	50
Depth	520	520
Built-In Cut Out (W x D) mm	880 x 490	750 x 490

# INDUCTION HOBS

GLASS-CERAMIC INDUCTION HOBS

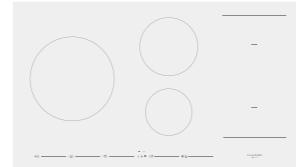

	FSH 905 ID TS WH 1	FSH 804 ID TS WH 1
Type	5-zone induction hob	4-zone induction hob
Finish	White Glass Ceramic	White Glass Ceramic
<b>INDUCTION PERFORMANCE</b>		
Ø 260	2600 / 3700 W	-
Octagonal	2100 / 3700 (x2) W	2300 / 3700 (x2) W
Ø 210	-	2300 / 3700 W
Ø 180	1850 / 3000 W	1850 / 3000 W
Ø 145	1400 / 2200 W	-
Assisted cooking 42 °C (Melt) 70°C slow cooking, 94°C simmering	•	•
Max electrical power (W)	11040 W max	7360 W max
<b>FEATURES</b>		
SLIDER sensor controls with buzzer	•	•
Electronic cooking start device	•	•
Timer for each zone with automatic power off	•	•
Residual heat indicator	•	•
Function lock and power on sensor	•	•
Cooking level number	9+P	9+P
Digital display of the selected power	•	•
<b>ACCESSORIES</b>		
Hob cleaning spatula	•	•
Power cord	•	•
<b>DIMENSIONS</b>		
Dim. Product (W x H x D) mm	900 x 55 x 510	800 x 55 x 515
Built-In Cut Out (D x W)	490 x 880	490 x 750

# INDUCTION HOBS

GLASS-CERAMIC INDUCTION HOB



	FSH 402 ID TS ...
Type	2 cooking zones
Glass-ceramic finish	Black Glass Ceramic <b>BK</b> White Glass Ceramic <b>WH</b>
<b>PERFORMANCE</b>	
Octa Bridge N.   Pot. MIN / MAX	1 Vertical   2100 / 3700 W
Ø Dual zone	1
Voltage / Frequency (V - Hz)	220 - 240 V; 50 - 60 Hz
Maximum power absorbed (W)	3680 W
Preset temperatures 42°C Melt	•
70°C Slow cooking	•
90°C Simmering	•
<b>CONTROLS</b>	
Operating system	Slider touch
AUTO cooking	•
Timer	•
Residual heat indicator (H)	•
Keypad safety lock	•
Power levels + Booster (P)	9+P
Digital display	•
<b>ACCESSORIES</b>	
Scraper	•
Power cord	•
<b>DIMENSIONS</b>	
Width (mm)	400
Height (mm)	50
Depth (mm)	520
Built-In Cut Out (W x D) mm	490 x 280

# INDUCTION HOBS

GLASS-CERAMIC INDUCTION HOBS



FCHH 905 ID TS G ...	
Type	5 cooking zones
Finish	Black Glass Ceramic <b>DWK BK</b> White Glass Ceramic <b>DWK WH</b>
<b>INDUCTION PERFORMANCE</b>	
Octa Bridge N.   Pot. MIN / MAX	2 Vertical   2100 / 3000 W
Max electrical power (W)	7360 W
<b>GAS BURNER PERFORMANCE</b>	
Brass WOK DUAL burner	4 kW
Cast iron grate	•
<b>FEATURES</b>	
Operating system	Slider Touch
AUTO cooking / Timer	• / •
Residual heat detector (H)	•
Keypad lock	•
Power levels no.	9 + P
Digital display	•
Electric ignition under the gas burner knob	•
Gas safety / Double regulation	• / •
<b>ACCESSORIES</b>	
Scraper	•
Moka Reducer	•
Wok Reducer	•
Power cord	•
<b>DIMENSIONS</b>	
Dim. Product (W x H x D) mm	900 x 56 x 520
Built-In Cut Out (W x D) mm	880 x 490

# INDUCTION HOBS

GLASS-CERAMIC INDUCTION HOBS



FCHL 904 ID TS ...	
Type	4 in-line cooking zones
Finish	Black Glass Ceramic <b>BK</b> White Glass Ceramic <b>WH</b>
<b>INDUCTION PERFORMANCE</b>	
Octa Bridge N.   Pot. MIN / MAX	2 Horizontal   2100 / 3000 W
Max electrical power (W)	7360 W
<b>GAS BURNER PERFORMANCE</b>	
Brass WOK DUAL burner	-
Cast iron grate	-
<b>FEATURES</b>	
Operating system	Slider Touch
AUTO cooking / Timer	• / •
Residual heat detector (H)	•
Keypad lock	•
Power levels no.	9 + P
Digital display	•
Electric ignition under the gas burner knob	-
Gas safety / Double regulation	-
<b>ACCESSORIES</b>	
Scraper	•
Moka Reducer	-
Wok Reducer	-
Power cord	•
<b>DIMENSIONS</b>	
Dim. Product (W x H x D) mm	900 x 55 x 400
Built-In Cut Out (W x D) mm	880 x 380

## INDUCTION HOBS

GLASS-CERAMIC INDUCTION HOBS

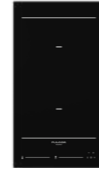
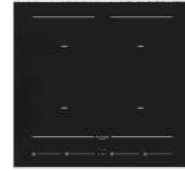
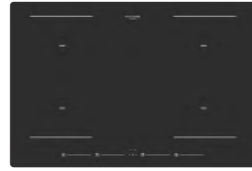

	FCH 804 ID TS ...	FCH 604 ID TS ...	FCH 302 ID TS ...
Type	4 cooking zones	4 cooking zones	2 cooking zones
Finish	Black Glass Ceramic <b>BK</b> White Glass Ceramic <b>WH</b>	Black Glass Ceramic <b>BK</b> White Glass Ceramic <b>WH</b>	Black Glass Ceramic <b>BK</b> White Glass Ceramic <b>WH</b>
<b>PERFORMANCE</b>			
Octa Bridge N.   Pot. MIN / MAX	2 Bridge Zones   2100 / 3000 W	2 Bridge Zones   2100 / 3000 W	1 Bridge Zone   2100 / 3000 W
Consumption reduction, removable	•	•	-
Max electrical power (W)	7360 W	7360 W	3680 W
<b>FEATURES</b>			
Operating system	Slider Touch	Slider Touch	Slider Touch
AUTO cooking	•	•	•
Timer	•	•	•
Residual heat detector (H)	•	•	•
Keypad lock	•	•	•
Power levels no.	9 + P	9 + P	9 + P
Digital display	•	•	•
<b>ACCESSORIES</b>			
Scraper	•	•	•
Power cord	•	•	•
<b>DIMENSIONS</b>			
Width (mm)	800	600	300
Height (mm)	50	50	50
Depth	520	520	520
Built-In Cut Out (W x D) mm	750 x 490 W	560 x 490	268 x 490

## INDUCTION HOBS

MATTE GLASS CERAMIC INDUCTION HOBS



	FSH 905 ID WT MBK	FSH 804 ID WT MBK
Type	5 cooking zones	4 cooking zones
Finish	Matte Black Glass Ceramic	Matte Black Glass Ceramic
<b>INDUCTION PERFORMANCE</b>		
Ø 290 / 180 DUAL MAX POWER	3000 / 5500 W	3000 / 5500 W
Octa Flexi N. - MIN / MAX power	2 Vertical - 2100 / 3700 (x 4) W	1 Vertical - 2100 / 3700 (x 2) W
Ø 145	-	1400 / 2200 W
Max electrical power (W)	11040 W	7360 W
Voltage / Frequency (V - Hz)	220 - 240 V; 50 - 60 Hz	220 - 240 V; 50 - 60 Hz
Preset temperatures 42° C (Melt)	•	•
70° C Slow cooking / 90° C Simmering	• / •	• / •
<b>INDUCTION CONTROLS</b>		
Programming	Wave Touch	Wave Touch
AUTO cooking	•	•
Timer	•	•
Residual heat detector (H)	•	•
Buzzer / Keypad lock	• / •	• / •
Power levels no.	9 + P	9 + P
Digital display	•	•
<b>ACCESSORIES</b>		
Scraper / Power cord	• / •	• / •
<b>DIMENSIONS</b>		
Dim. Product (W x H x D) mm	900 x 45 x 520	800 x 45 x 520
Built-In Cut Out (W x D) mm	880 x 490	750 x 490

## GAS HOBS

GLASS-CERAMIC GAS HOBS



	FCLH 905 G T WK BK	FCLH 755 G T WK BK
Type	Gas hob 90	Gas hob 80
Finish	Black Glass Ceramic	Black Glass Ceramic
Surface	Glass-ceramic	Glass-ceramic
<b>GAS BURNER PERFORMANCE</b>		
Front RH	1000 W	1000 W
Rear RH	3000 W	3000 W
LH	4000 W	4000 W
Front centre	1750 W	1750 W
Rear centre	1750 W	1750 W
Front LH	-	-
<b>CONTROLS - FEATURES</b>		
HALO VISION back-lit knobs	•	•
Electric ignition under the knob	•	•
Gas safety	•	•
Timer / Display	• / •	• / •
Cast-iron racks / Brass burners no.	• / 5	• / 5
<b>ACCESSORIES</b>		
Wok adapter	•	•
Wok Reducer	•	•
Plug / Power cord	Schuko / •	Schuko / •
<b>DIMENSIONS</b>		
Width (mm)	900	760
Height (mm)	55	55
Depth (mm)	520	520
Built-In Cut Out (W x D) mm	840 x 490	650 x 490

## GAS HOBS

MATTE BLACK STEEL GAS HOBS



	FUH 604 G DWK MBK	FUH 755 G DWK MBK	FUH 7541 G DWK MBK
Type	Gas hob 60	Gas hob 75	Gas hob 75
Finish	Matte Black Metal	Matte Black Metal	Matte Black Metal
<b>GAS BURNER PERFORMANCE</b>			
Front RH	1000 W	1000 W	1000 W
Rear RH	3000 W	3000 W	3000 W
LH	-	4000 W	-
Front LH	4000 W	-	1750 W
Rear LH	1750 W	-	1750 W
Centre	-	-	4000 W
Front centre	-	1750 W	-
Rear centre	-	1750 W	-
<b>CONTROLS - FEATURES</b>			
Knob regulation / type	• / Matte black	• / Matte black	• / Matte black
Electric ignition under the knob	•	•	•
Gas safety	•	•	•
Cast-iron racks / matte brass burners no.	• / 4	• / 5	• / 5
<b>ACCESSORIES</b>			
Wok adapter	•	•	•
Power cord	•	•	•
Plug	Schuko	Schuko	Schuko
<b>DIMENSIONS</b>			
Width (mm)	620	760	760
Height (mm)	55	55	55
Depth (mm)	520	520	520
Built-In Cut Out (W x D) mm	560 x 490	560 x 490	560 x 490

## GAS HOBS

MATTE BLACK STEEL GAS HOBS



	FUH 905 G DWK MBK	FUH 9041 G DWK MBK
Type	Gas hob 90	Gas hob 90
Finish	Matte Black Metal	Matte Black Metal
<b>GAS BURNER PERFORMANCE</b>		
Front RH	1000 W	1000 W
Rear RH	3000 W	3000 W
LH	4000 W	-
Front LH	-	1750 W
Rear LH	-	1750 W
Centre	-	4000 W
Front centre	1750 W	-
Rear centre	1750 W	-
<b>CONTROLS - FEATURES</b>		
Knob regulation / type	• / Matte black	• / Matte black
Electric ignition under the knob	•	•
Gas safety	•	•
Cast-iron grids / matte brass burners no.	• / 5	• / 5
<b>ACCESSORIES</b>		
Wok adapter	•	•
Power cord	•	•
Plug	Schuko	Schuko
<b>DIMENSIONS</b>		
Width (mm)	900	900
Height (mm)	55	55
Depth (mm)	520	520
Built-In Cut Out (W x D) mm	840 x 490	840 x 490

## GAS HOBS

STEEL GAS HOBS



	FPH 906 G WK X	FPH 905 G WK X	FPH 9041 G WK X
Type	Gas hob 90	Gas hob 90	Gas hob 90
Finish	Stainless Steel	Stainless Steel	Stainless Steel
<b>GAS BURNER PERFORMANCE</b>			
Front RH	1000 W	1000 W	1000 W
Rear RH	3000 W	3000 W	3000 W
LH wok	-	4000 W	-
Front LH	4000 W	-	1750 W
Rear LH	1750 W	-	1750 W
Centre	-	-	4000 W
Front centre	1750 W	1750 W	-
Rear centre	1750 W	1750 W	-
<b>CONTROLS - FEATURES</b>			
Knob regulation	•	•	•
Electric ignition under the knob	•	•	•
Gas safety	•	•	•
Cast-iron grids / Burners - brass ring	• / 6	• / 5	• / 5
<b>ACCESSORIES</b>			
Wok adapter	•	•	•
<b>POWER RATING</b>			
Voltage / Frequency (V - Hz)	220 - 240 V; 50 - 60 Hz	220 - 240 V; 50 - 60 Hz	220 - 240 V; 50 - 60 Hz
Power cord	•	•	•
Plug	Schuko	Schuko	Schuko
<b>DIMENSIONS</b>			
Dim. Product (W x H x D) mm	900 x 55 x 520	900 x 55 x 520	900 x 55 x 520
Built-In Cut Out (W x D) mm	840 x 490	840 x 490	840 x 490

## GAS HOBS

STEEL GAS HOBS



	FPH 755 G WK X	FPH 7541 G WK X	FPH 604 G WK X
Type	Gas hob 75	Gas hob 75	Gas hob 60
Finish	Stainless Steel	Stainless Steel	Stainless Steel
<b>GAS BURNER PERFORMANCE</b>			
Front RH	1000 W	1000 W	1000 W
Rear RH	3000 W	3000 W	3000 W
LH wok	4000 W	-	-
Front LH	-	1750 W	4000 W
Rear LH	-	1750 W	1750 W
Centre	-	4000 W	-
Front centre	1750 W	-	-
Rear centre	1750 W	-	-
<b>CONTROLS - FEATURES</b>			
Knob regulation	•	•	•
Electric ignition under the knob	•	•	•
Gas safety	•	•	•
Cast-iron grids / Burners - brass ring	• / 5	• / 5	• / 4
<b>ACCESSORIES</b>			
Wok adapter	•	•	•
<b>POWER RATING</b>			
Voltage / Frequency (V - Hz)	220 - 240 V; 50 - 60 Hz	220 - 240 V; 50 - 60 Hz	220 - 240 V; 50 - 60 Hz
Power cord	•	•	•
Plug	Schuko	Schuko	Schuko
<b>DIMENSIONS</b>			
Width (mm)	760	760	620
Height (mm)	55	55	55
Depth (mm)	520	520	520
Built-In Cut Out (W x D) mm	560 x 490	560 x 490	560 x 490

## GAS HOBS

GLASS GAS HOBS



	FPH 905 G WK ...	FPH 755 G WK ...	FPH 604 G WK ...
Type	Gas hob 90	Gas hob 75	Gas hob 60
Finish	Black Glass White Glass	Black Glass White Glass	Black Glass White Glass
	<b>BKG</b> <b>WHG</b>	<b>BKG</b> <b>WHG</b>	<b>BKG</b> <b>WHG</b>
<b>GAS BURNER PERFORMANCE</b>			
Front RH	1000 W	1000 W	1000 W
Rear RH	3000 W	3000 W	3000 W
LH wok	4000 W	4000 W	-
Front LH	-	-	4000 W
Rear LH	-	-	1750 W
Front centre	1750 W	1750 W	-
Rear centre	1750 W	1750 W	-
<b>CONTROLS - FEATURES</b>			
Knob regulation	•	•	•
Electric ignition under the knob	•	•	•
Gas safety	•	•	•
Cast-iron grids / Burners - brass ring	• / 5	• / 5	• / 4
<b>ACCESSORIES</b>			
Wok adapter	•	•	•
<b>POWER RATING</b>			
Voltage / Frequency (V - Hz)	220 - 240 V; 50 - 60 Hz	220 - 240 V; 50 - 60 Hz	220 - 240 V; 50 - 60 Hz
Power cord	•	•	•
Plug	Schuko	Schuko	Schuko
<b>DIMENSIONS</b>			
Width (mm)	900	760	620
Height (mm)	55	55	55
Depth (mm)	520	520	520
Built-In Cut Out (W x D) mm	840 x 490	560 x 490	560 x 490

## GAS HOBS

STEEL GAS HOBS



	CPH 1124 GWK X	CPH 905 GWK X	CPH 765 GWK X	CPH 604 G X
Type	4 In-line cooking zones	5 cooking zones	5 cooking zones	4 cooking zones
Finish	Stainless Steel	Stainless Steel	Stainless Steel	Stainless Steel
Grids	Cast-iron	Cast-iron	Cast-iron	Cast-iron
<b>PERFORMANCE</b>				
Front RH	3000 W	1750 W	1750 W	1750 W
Rear RH	-	1750 W	1750 W	1750 W
Central RH	1000 W	-	-	-
Central	-	4000 W	4000 W	-
Central LH	1750 W	-	-	-
Front LH	4000 W	1000 W	1000 W	1000 W
Rear LH	-	3000 W	3000 W	3000 W
<b>OTHER FEATURES</b>				
Controls	Metal knobs	Metal knobs	Metal knobs	Metal knobs
Electric ignition under the knob	•	•	•	•
Gas safety	•	•	•	•
<b>ACCESSORIES</b>				
Cast iron Wok adapter	•	•	•	-
Cast-iron reduction grid	•	•	•	•
<b>POWER RATING</b>				
Voltage / Frequency (V - Hz)	220 - 240 V; 50 - 60 Hz	220 - 240 V; 50 - 60 Hz	220 - 240 V; 50 - 60 Hz	220 - 240 V; 50 - 60 Hz
Power cord	•	•	•	•
Plug	Schuko	Schuko	Schuko	Schuko
<b>DIMENSIONS</b>				
Width (mm)	1120	860	770	590
Height (mm)	75	75	75	75
Depth (mm)	384	510	510	510
Built-In Cut Out (W x D) mm	1100 x 365	840 x 490	750 x 490	560 x 490

## GAS HOBS

STEEL GAS HOBS

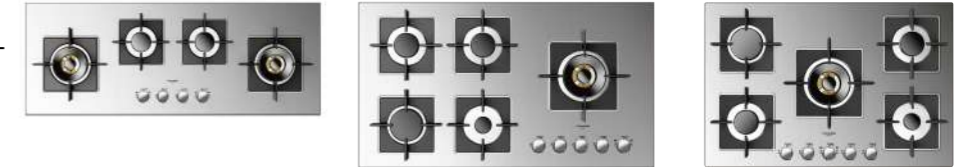

	FSH 1124 G 2DWK XX	FSH 905 G DWK XX	FSH 775 G DWK XX
Type	4 In-line cooking zones	5 cooking zones	5 cooking zones
Finish	Stainless Steel	Stainless Steel	Stainless Steel
Grids	Cast-iron	Cast-iron	Cast-iron
<b>PERFORMANCE</b>			
Front RH	4000 W	4000 W	1000 W
Rear RH	-	-	1750 W
Front Centre RH	1750 W	1000 W	4000 W
Rear Centre RH	-	1750 W	-
Front Centre LH	1750 W	-	-
Front LH	4000 W	3000 W	1750 W
Rear LH	-	1750 W	3000 W
<b>FEATURES</b>			
Knob regulation / type	• / Metal knobs	• / Metal knobs	• / Metal knobs
Electric ignition under the knob	•	•	•
Gas safety / Gas types	• / NG - LPG	• / NG - LPG	• / NG - LPG
<b>ACCESSORIES</b>			
Wok adapter	•	•	•
Adapter for small pans	•	•	•
<b>POWER RATING</b>			
Voltage / Frequency (V - Hz)	220 - 240 V; 50 - 60 Hz	220 - 240 V; 50 - 60 Hz	220 - 240 V; 50 - 60 Hz
Power cord	•	•	•
Plug	Schuko	Schuko	Schuko
<b>DIMENSIONS</b>			
Width (mm)	1120	900	770
Height (mm)	55	50	55
Depth (mm)	425	520	510
Built-In Cut Out (W x D) mm	1100 x 405	880 x 490	750 x 490

# GAS HOBS

GLASS GAS HOBS



	FCH 1124 G 2DWK BK	FCH 905 G DWK BK	FCH 775 G WK BK	FCH 604 G BK
Type	4 In-line cooking zones	5 cooking zones	5 cooking zones	4 cooking zones
Finish	Black Glass	Black Glass	Black Glass	Black Glass
Grids	Cast-iron	Cast-iron	Cast-iron	Cast-iron
<b>PERFORMANCE</b>				
Front RH	4000 W	4000 W	1000 W	1000 W
Rear RH	-	-	1750 W	1750 W
Front Centre RH	1750 W	1000 W	4000 W	-
Rear Centre RH	-	1750 W	-	-
Front Centre LH	1750 W	-	-	3000 W
Front LH	4000 W	4000 W	1750 W	1750 W
Rear LH	-	1750 W	3000 W	-
<b>FEATURES</b>				
Knob regulation / type	• / Metal knobs	• / Metal knobs	• / Metal knobs	• / Metal knobs
Electric ignition under the knob	•	•	•	•
Gas safety	•	•	•	•
Gas types	NG / LPG	NG / LPG	NG / LPG	NG / LPG
<b>ACCESSORIES</b>				
Wok adapter	•	•	•	•
Adapter for small pans	•	•	•	•
<b>POWER RATING</b>				
Voltage / Frequency (V - Hz)	220 - 240 V; 50 - 60 Hz	220 - 240 V; 50 - 60 Hz	220 - 240 V; 50 - 60 Hz	220 - 240 V; 50 - 60 Hz
Power cord / Plug	• / Schuko	• / Schuko	• / Schuko	• / Schuko
<b>DIMENSIONS</b>				
Width (mm)	1120	909	770	580
Height (mm)	55	50	55	55
Depth (mm)	425	510	510	510
Built-In Cut Out (W x D) mm	1100 x 405	840 x 490	750 x 490	560 x 490

# GAS HOBS

STEEL GAS HOBS



	QH 1124 GWK X	QH 906 GWK X	QH 765 GWK X	QH 604 GWK X
Type	4 in-line cooking zones	6 cooking zones	5 cooking zones	4 cooking zones
Finish	Stainless Steel	Stainless Steel	Stainless Steel	Stainless Steel
Grids	Cast-iron	Cast-iron	Cast-iron	Cast-iron
<b>PERFORMANCE</b>				
Front RH	3000 W	1000 W	1750 W	1000 W
Rear RH	-	3000 W	1750 W	3000 W
Front Centre RH	1750 W	1750 W	1000 W	-
Rear Centre RH	-	1000 W	3000 W	-
Front Centre LH	1000 W	-	-	-
Front LH	4000 W	4000 W	4000 W	4000 W
Rear LH	-	1750 W	-	1750 W
<b>FEATURES</b>				
Knob regulation / type	• / Metal knobs	• / Metal knobs	• / Metal knobs	• / Metal knobs
Electric ignition under the knob	•	•	•	•
Gas safety	•	•	•	•
<b>ACCESSORIES</b>				
Wok adapter	•	•	•	•
Adapter for small pans	•	•	•	•
<b>POWER RATING</b>				
Voltage / Frequency (V - Hz)	220 - 240 V; 50 - 60 Hz	220 - 240 V; 50 - 60 Hz	220 - 240 V; 50 - 60 Hz	220 - 240 V; 50 - 60 Hz
Power cord	•	•	•	•
Plug	Schuko	Schuko	Schuko	Schuko
<b>DIMENSIONS</b>				
Width (mm)	1120	909	760	620
Height (mm)	55	50	50	50
Depth (mm)	425	510	510	510
Built-In Cut Out (W x D) mm	1100 x 405	840 x 490	560 x 480	560 x 480

## COMBISET

STEEL GAS HOBS



	CPH 401 G DWK X	CPH 402 G X
Type / Finish	Large cooking zone / Stainless Steel	2 cooking zones / Stainless Steel
Grids	Cast-iron	Cast-iron
<b>PERFORMANCE</b>		
Front	-	1000 W
Central	4000 W	-
Rear	-	3000 W
<b>OTHER FEATURES</b>		
Regulation with metal knobs no.	1	2
DUAL regulation	•	-
Electric ignition under the knob	•	•
Gas safety	•	•
<b>ACCESSORIES</b>		
Power cord / Schuko plug	• / •	• / •
Cast iron Wok adapter	•	-
<b>DIMENSIONS</b>		
Product (W x H x D) mm	380 x 73 x 510	380 x 73 x 510
Built-In Cut Out (W x D) mm	360 x 490	360 x 490

## COMBISET

STEEL INDUCTION HOBS



	CPH 402 ID TY TC X/2	CPH 402 ID TC X/2
Type / Finish	Induction Teppan Yaki / Stainless Steel	2 induction / Stainless Steel cooking areas
<b>PERFORMANCE</b>		
Ø 180	1400 W	1400 W
Ø 160	1400 W	1400 W
Max electrical power (W)	2800 W	2800 W
<b>FEATURES</b>		
Operating system / Digital display	Touch control / •	Touch control / •
AUTO cooking	-	•
Timer up to 99 minutes	•	•
Power levels no.	9 + P	9 + P
Keypad lock / Residual heat detector	• / •	• / •
<b>ACCESSORIES</b>		
Scraper	-	•
Power cord / Schuko plug	• / •	• / •
<b>DIMENSIONS</b>		
Product (W x H x D) mm	380 x 70 x 510	380 x 64 x 510
Built-In Cut Out (W x D) mm	360 x 490	360 x 490

## COMBISET

STEEL INDUCTION HOBS



	CPH 402 ID X	CPH 401 ID X
Type / Finish	2 cooking zones / Stainless Steel	1 large cooking zone / Stainless Steel
<b>PERFORMANCE</b>		
Ø 260	-	2300 / 3000 W
Ø 180	1400 / 2000 W	-
Ø 160	1400 W	-
Max electrical power (W)	3450 W	3000 W
<b>FEATURES</b>		
Regulation with metal knobs no.	2	1
Power levels no.	9 + P	9 + P
Residual heat detector (H)	•	•
<b>ACCESSORIES</b>		
Scraper / Power cord	• / •	• / •
<b>DIMENSIONS</b>		
Product (W x H x D) mm	380 x 60 x 510	380 x 60 x 510
Built-In Cut Out (W x D) mm	360 x 490	360 x 490

## COMBISET

ELECTRIC STEEL HOBS



	CPH 401 BQ X	CPH 401 FR X
Type / Finish	Electric Grill / Stainless steel	Electric fryer / Stainless steel
<b>PERFORMANCE</b>		
Heating element	1	1
Max electrical power (W)	2400 W	2300 W
<b>FEATURES</b>		
Knob controls / Cooking levels no.	• / 11	• / -
Temp. regulation / Operation indicator	- / •	• / •
Safety switch for maintaining the oil temperature	-	•
<b>ACCESSORIES</b>		
Removable stainless steel container	•	•
Steel frying rack with flip-up handle	-	•
Power cord / Schuko plug	• / •	• / •
<b>DIMENSIONS</b>		
Width (mm) / Recessed compartment (DxW) mm	380 x 77 x 510 / 490x360	380 x 181 x 510 / 490x360

# EXTRACTION

DOWNDRAFT (LIFT) HOODS



	FDDH 1120 TRC ...	FDDH 900 TRC ...
Type	Downdraft	Downdraft
Finish	Stainless steel Black Glass White Glass	Stainless steel Black Glass White Glass
Installation	On the countertop	On the countertop
<b>FEATURES</b>		
Efficiency class	A	A
Extraction levels	4	4
Auto power off	•	•
Anti-grease filter saturation indicator	•	•
Carbon filter saturation indicator (filtering)	•	•
Lighting	LED bar	LED bar
Type of anti-grease filters	Aluminium	Aluminium
Dishwasher-safe anti-grease filters	•	•
Minimum air outlet tube ø	Ø 150 mm / rect. 220 x 90 x (230 x 80)	Ø 150 mm / rect. 220 x 90 x (230 x 80)
Airflow non-return valve	•	•
<b>CONTROLS</b>		
Operating system / Remote control	Touch control / •	Touch control / •
<b>PERFORMANCE / ELECTRICAL DATA</b>		
Suction power m³/h (max) with FDD2M / FEM1 / FEM2	790 - 740 / 790	760 - 680 / 730
Noise (dBA) with FDD2M / FEM1 / FEM2 min.- max	39 - 68 / 28 - 55 / 39-57	38 - 68 / 28-59 / 43 - 62
Annual consumption (kWh) FDD2M / FEM1 / FEM2	51.9 / 49.9 / 99.4	44.5 / 58.5 / 87
Motor power (W) FDD2M / FEM1 / FEM2	275 / 275 / 200	275 / 275 / 200
Voltage / Frequency (V-Hz)	230 - 240 / 50 - 60	230 - 240 / 50 - 60
Power cord (m)	2	2
<b>ACCESSORIES</b>		
Motor included	-	-
On-Board motor (on request)	FDD 2M	FDD 2M
Internal remote motor (on request)	FEM 1	FEM 1
External remote motor on request	FEM 2	FEM 2
HP filter for filtering version (on request)	FCHF 12	FCHF 9
<b>DIMENSIONS</b>		
Width (mm)	1120	790
Height (mm)	min.740 max 1040	min.740 max 1040
Depth (mm)	96 + motor	96 + motor

# EXTRACTION

DOWNDRAFT WALL-MOUNTED HOOD



	FCLHD 900 TC BK
Type	Electronic
Finish	Black Glass
Installation	Wall-mounted
Special feature	Automatic Cooking
<b>FEATURES</b>	
Efficiency class	A +
Extraction levels	4
Power off timer	•
Anti-grease filter saturation indicator	•
HP filter saturation indicator	•
Lighting	LED
Type of anti-grease filters	Aluminium
Aluminium anti-grease filters	•
Minimum air outlet tube ø	Ø 150 mm / rect.
Airflow non-return valve	•
<b>CONTROLS</b>	
Programming	Touch controls
Remote control	-
<b>PERFORMANCE / ELECTRICAL DATA</b>	
Extraction power m³/h (max)	760
Noise (dBA)	49 - 71
Annual consumption (kWh)	46
Motor power (W)	275
Voltage / Frequency (V - Hz)	230 - 50
Power cord (m)	2
Plug (Schuko)	•
<b>ACCESSORIES</b>	
Motor included	•
HP filter for filtering version (on request)	FCHF 18
<b>DIMENSIONS</b>	
Width (mm)	900
Height (mm)	890 - 1100
Depth (mm)	450

# EXTRACTION

COOKTOP HOODS



	FPHD 52 TS BK	FPHD 51 TS X
Type	Cooktop hood	Cooktop hood
Installation	Cooktop hood	Cooktop hood
Finish	Black Glass Ceramic	Stainless Steel
<b>HOOD FEATURES</b>		
Efficiency class	A +	A +
Extraction levels	5	A +
Power off timer	•	A +
Filter saturation indicator with oil-collection tray	•	•
Aluminium and stainless steel anti-grease filters	•	•
Minimum air tube ø Ø	Ø 150 mm / rect. 220 x 90 (230 x 80)	Ø 150 mm / rect. 220 x 90 (230 x 80)
Airflow non-return valve	•	•
<b>CONTROLS</b>		
Operating system	Touch control	Touch control
<b>PERFORMANCE / ELECTRICAL DATA</b>		
Extraction power up to m³/h	700 m³/h	700 m³/h
Sound emissions (dBA)	55 - 70	55 - 70
Estimated annual consumption (kWh)	49	49
Motor power (W)	168 W	168 W
Voltage / Frequency (V - Hz)	220 / 40 - 50 / 60	220 / 40 - 50 / 60
Power cord (m)	2	2
Plug (Schuko)	v	•
<b>ACCESSORIES</b>		
Motor included	•	•
HP filter for filtering version (on request)	FCHF 45 (X2)	FCHF 45 (X2)
<b>DIMENSIONS</b>		
Width (mm)	520	510
Height (mm)	140	140
Depth (mm)	200	200

# EXTRACTION

CEILING-MOUNTED HOODS



	FCHD 1200 RC ...	FCHD 900 RC ...
Type	Integrated	Integrated
Finish	Stainless steel White Glass	Stainless steel White Glass
	<b>X</b> <b>WH</b>	<b>X</b> <b>WH</b>
Installation	Ceiling-mounted	Ceiling-mounted
<b>FEATURES</b>		
Efficiency class	B	B
Extraction levels	4	4
Power off timer	•	•
Anti-grease filter saturation indicator	•	•
HP filter saturation indicator (filtering)	•	•
Lighting /	LED / 4 spot	LED / 3 spot
Washable aluminium anti-grease filters	•	•
Minimum air outlet tube ø ø	Ø 150 mm / rect.	Ø 150 mm / rect.
Airflow non-return valve	•	•
<b>CONTROLS</b>		
Remote control	•	•
<b>PERFORMANCE / ELECTRICAL DATA</b>		
Extraction power m³/h (max)	600	600
Noise (dBA)	53 - 64	53 - 64
Annual consumption (kWh)	54	54
Motor power (W)	110	110
Voltage / Frequency (V - Hz)	230 - 50	230 - 50
Power cord (m) / Plug (Schuko)	2 / •	2 / •
<b>ACCESSORIES</b>		
Motor included	•	•
HP filter for filtering version (on request)	FCHF 2	FCHF 2
<b>DIMENSIONS</b>		
Space-saving dimensions 200 mm	•	•
Dim. Product (W x H x D) mm	1200 x 100 - 180 x 650	900 x 100 - 180 x 550

# EXTRACTION

ISLAND HOODS



	FTIHD 1260 TC X	FTIHD 960 TC ...
Type	Visible	Visible
Finish	Stainless steel	Stainless steel <b>X</b> Black Glass <b>BK X</b> White Glass <b>WH X</b>
Installation	Island-mounted	Island-mounted
<b>FEATURES</b>		
Efficiency class	A	A
Extraction levels	4	4
Auto power off	10 minutes	10 minutes
Anti-grease filter saturation indicator	•	•
HP filter saturation indicator (filtering)	•	•
Lighting	Front and rear LED bar	Front and rear LED bar
Type of anti-grease filters	PRO stainless steel baffle	PRO stainless steel baffle
Dishwasher-safe anti-grease filters	•	•
Minimum air outlet tube ø	Ø 150 mm / rect.	Ø 150 mm / rect.
Airflow non-return valve	•	•
<b>CONTROLS</b>		
Operating system	Touch control	Touch control
Remote control	•	•
<b>PERFORMANCE / ELECTRICAL DATA</b>		
Extraction power m³/h (max)	730	730
Noise (dBA)	47 - 72	47 - 72
Annual consumption (kWh)	49	49
Motor power (W)	275	275
Voltage / Frequency (V - Hz)	220 - 240 / 50	220 - 240 / 50
Power cord (m)	2	2
Plug (Schuko)	•	•
<b>ACCESSORIES</b>		
Motor included	•	•
HP filter for filtering version (on request)	FCHF 49 (X2)	FCHF 49 (X2)
<b>DIMENSIONS</b>		
Width (mm)	1200	900
Height (mm)	755 - 1174	755 - 1174
Depth (mm)	600	600

# EXTRACTION

WALL-MOUNTED HOODS



	FTHD 1200 TC X	FTHD 900 TC ...
Type	Visible	Visible
Finish	Stainless steel	Stainless steel <b>X</b> Black Glass <b>BK X</b> White Glass <b>WH X</b>
Installation	Wall-mounted	Wall-mounted
<b>FEATURES</b>		
Efficiency class	A	A
Extraction levels	5	4
Auto power off	• 10 minutes	• 10 minutes
Anti-grease filter saturation indicator	•	•
HP filter saturation indicator (filtering)	•	•
Lighting	LED bar	LED bar
Type of anti-grease filters	PRO stainless steel baffle	PRO stainless steel baffle
Dishwasher-safe anti-grease filters	•	•
Minimum air outlet tube ø	Ø 150 mm / rect.	Ø 150 mm / rect.
Airflow non-return valve	•	•
<b>CONTROLS</b>		
Operating system	Touch control	Touch control
Remote control	•	•
<b>PERFORMANCE / ELECTRICAL DATA</b>		
Extraction power m³/h (max)	730	730
Noise (dBA)	47 - 72	47 - 72
Annual consumption (kWh)	49	49
Motor power (W)	275	275
Voltage / Frequency (V - Hz)	230 - 50	230 - 50
Power cord (m)	2	2
Plug (Schuko)	•	•
<b>ACCESSORIES</b>		
Motor included	•	•
HP filter for filtering version (on request)	FCHF 49 (X2)	FCHF 49 (X2)
<b>DIMENSIONS</b>		
Width (mm)	1200	900
Height (mm)	1200	605 - 1030
Depth (mm)	500	505

## EXTRACTION

INSERTION HOODS



	FBHD 900 PT X - FBHD 700 PT X	FBGHD 800 PT X	FBGHD 850 TC X
Type	Integrated	Integrated	Integrated
Finish	Stainless steel	Stainless steel	Stainless steel
Installation	In wall unit	In wall unit	Under cabinet
<b>FEATURES</b>			
Efficiency class	A	A	A +
Extraction levels	4	4	4
Timer and auto power off	•	•	•
Anti-grease filter saturation indicator	•	•	•
HP filter saturation indicator (filtering)	•	•	•
Lighting	LED / 4 spot	LED bar	LED
Type of anti-grease filters	Aluminium	Aluminium	Aluminium
Dishwasher-safe anti-grease filters	•	•	•
Minimum air outlet tube ø	Ø 150 mm / rect.	Ø 150 mm / rect.	Ø 150 mm / rect.
Airflow non-return valve	•	•	•
<b>CONTROLS</b>			
Operating system	Soft touch	Soft touch	Touch control
<b>PERFORMANCE / ELECTRICAL DATA</b>			
Extraction power m³/h (max)	700	700	780
Noise (dBA)	47 - 70	47 - 70	45 - 71
Annual consumption (kWh)	50	50	45
Motor power (W)	275	275	275
Voltage / Frequency (V - Hz)	230 - 50	230 - 50	230 - 50
Power cord (m)	2	2	2
Plug (Schuko)	•	•	•
<b>ACCESSORIES</b>			
Motor included	•	•	•
HP filter for filtering version (on request)	FCHF 13	FCHF 13	FCHF 8 (X2)
<b>DIMENSIONS</b>			
Width (mm)	900 and 700	780	850
Height (mm)	325	440	350
Depth (mm)	290	290	290

## REFRIGERATION

REFRIGERATORS



	FBCD 761 TNF EDBL	FBCD 762 TNF EDBL
Type	Combined	Combined
Finish	Built-In	Built-In
Fixing	Self-supporting hinges	Self-supporting hinges
Reversible doors	•	•
<b>PERFORMANCE</b>		
Total gross capacity	460 L	460 L
Total net capacity	452 L	452 L
Efficiency class	E	E
Energy consumption (KWh / year) based on results of standard testing over 24 hours*	467	551
Autonomy without electricity (h)	11	11
Freezing power (Kg / 24h)	5.8	5.8
Climate class	SN-T	SN-T
Sound level dB (A) re1pW	43	43
<b>GENERAL FEATURES</b>		
	Electronic regulation	Digital touch display
	Independent refrigerator temperature regulation / Freezer / fresh zone	Holiday function
	Temperature indicator	Open door buzzer
	LED lighting	Fast Freezing indicator
No. of compressors / type	1/Inverter	1/Inverter
Refrigerant gas	R600a	R600a
<b>REFRIGERATOR COMPARTMENT</b>		
Cooling system	No Frost	No Frost
Defrosting	Automatic	Automatic
Rear panel with LED light	•	•
"FRESH 0 °C" zone	•	•
Freshwater dispenser	-	•
Glass shelves	3	3
Egg container	•	•
Produce drawer	•	•
Refrigerator compartment volume	325 L	325 L
<b>FREEZER COMPARTMENT</b>		
Cooling system	No Frost	No Frost
Defrosting	Automatic	Automatic
Fast Freezing	•	•
Removable drawers	2	2
Automatic Ice Maker	-	•
Freezer compartment volume	127 L	127 L
<b>POWER RATING</b>		
Max power absorbed at 220 V	572W	572W
Power supply (V - Hz)	220-240 / 50-60	220-240 / 50-60
Plug (Schuko)	•	•
<b>WEIGHT, DIMENSIONS</b>		
Weight (kg)	148	155
Dim. Product (W x H x D) mm	2123 x 756 x 592-616	2123 x 756 x 592-616

# REFRIGERATION

## REFRIGERATORS



	FBCD 701 TNF EDBL	FBCD 355 TNF EDBL	FBC 345 TNF ED
Type	Combined	Combined	Combined
Finish	Built-In	Built-In	Built-In
Fixing	Self-supporting hinges	Self-supporting hinges	Towing
Reversible doors	•	•	•
<b>PERFORMANCE</b>			
Total gross capacity	350 L	252 L	252 L
Total net capacity	341 L	237 L	244 L
Efficiency class	E	E	E
Energy consumption (KWh / year) based on results of standard testing over 24 hours*	250	235	234
Autonomy without electricity (h)	11	11	11
Freezing power (Kg / 24h)	3.8	2.6	2.6
Climate class	SN-T	SN-T	SN-T
Sound level dB (A) re1pW	41	41	41
<b>GENERAL FEATURES</b>			
Electronic regulation	•	•	•
Digital display	•	•	•
Independent regulation Refrigerator / Freezer temperature	•	•	•
Holiday function	•	•	•
Open door buzzer	•	•	•
Temperature indicator	•	•	•
Fast Freezing indicator	•	•	•
Lighting	LED	LED	LED
No. of compressors / type	1/Inverter	1/Inverter	1/Inverter
Refrigerant gas	R600a	R600a	R600a
<b>REFRIGERATOR COMPARTMENT</b>			
Cooling system	No Frost	No Frost	No Frost
Defrosting	Automatic	Automatic	Automatic
Rear panel with LED light	•	•	-
"FRESH 0 °C" zone	•	•	•
Glass shelves	4	4	4
Egg container	•	•	•
Produce drawer	•	•	•
Refrigerator compartment volume	257 L	170 L	177 L
<b>FREEZER COMPARTMENT</b>			
Cooling system	No Frost	No Frost	No Frost
Defrosting	Automatic	Automatic	Automatic
Fast Freezing / Removable drawers	• / 3	• / 3	• / 3
Freezer compartment volume	84 L	67 L	67 L
<b>POWER RATING</b>			
Max power absorbed at 220 V	176W	176W	176W
Power supply (V - Hz)	220-240 / 50-60	220-240 / 50-60	220-240 / 50-60
Plug (Schuko)	•	•	•
<b>WEIGHT, DIMENSIONS</b>			
Weight (kg)	85	60	60
Dim. Product (W x H x D) mm	1937 x 690 x 550	1776 x 540 x 550	1776 x 540 x 550
Built-In Cut Out (HxWxD)	1939-1942 x 712 x 560	1778-1781 x 562 x 560	1778-1781 x 560 x 560

# REFRIGERATION

## REFRIGERATOR AND FREEZER



	FBR 300 F ED	FBF 290 NF ED
Type	Single door	Freezer
Finish	Built-In	Built-In
Fixing	Towing	Towing
Reversible doors	•	•
<b>PERFORMANCE</b>		
Total gross capacity	320 L	210 L
Total net capacity	316 L	200 L
Efficiency class	E	E
Energy consumption (KWh / year) based on results of standard testing over 24 hours*	114	234
Autonomy without electricity (h)	-	11
Freezing power (Kg / 24h)	-	9
Climate class	SN-T	SN-T
Sound level dB (A) re1pW	41	41
<b>GENERAL FEATURES</b>		
Electronic regulation	•	•
Digital display	•	•
Temperature regulation	•	•
Buzzer	-	•
Temperature indicator	•	•
Fast Freezing indicator	-	•
Lighting	LED	-
No. of compressors / type	1/Inverter	1/Inverter
Refrigerant gas	R600a	R600a
<b>REFRIGERATOR COMPARTMENT</b>		
Cooling system	Ventilated	-
Defrosting	Automatic static	-
Glass shelves	6	-
Egg container	•	-
Produce drawer	•	-
Refrigerator compartment volume	316 L	-
<b>FREEZER COMPARTMENT</b>		
Cooling system	-	No Frost
Defrosting	-	Automatic
Fast Freezing	-	•
Removable drawers / flaps	-	5 / 2
Freezer compartment volume	-	200 L
<b>POWER RATING</b>		
Max power absorbed at 220 V	176W	176W
Power supply (V - Hz)	220-240 / 50	220-240 / 50
Plug (Schuko)	•	•
<b>WEIGHT, DIMENSIONS</b>		
Weight (kg)	58	59
Height (mm)	1769	1769
Width (mm)	540	540
Depth (mm)	545	545
Built-In Cut Out (HxWxD)	1771-1774 x 560 x 555	1771-1774 x 560 x 555

# WINE CELLARS

WINE CELLAR 82



FWC 8200 U TC ...	
Type	Wine cellar
Finish	Undercounter
Bottle no. (Ø 76 mm)	39
Door finish	Stainless Steel Black Glass <b>BKX</b> <b>GBK</b>
Reversible door	•
<b>PERFORMANCE</b>	
Cooling system	Ventilated
Temperature zones	2
Adjustable upper zone temperature (°C)	from 5 to 20
Adjustable lower zone temperature (°C)	from 5 to 20
Efficiency class	G
Anti-vibration system	•
Anti-condensation system	•
Climate class	SN-T
Sound level dB (A) re1pW	38
<b>CONTROL SYSTEM</b>	
Electronic regulation	•
Digital touch display	•
Double automatic hot / cold circuit	•
Control light indicator	•
<b>ACCESSORIES</b>	
UV-insulating glass pane	•
Lighting	LED
Wooden shelves / type	4 / Beech
Champagne shelf (5 bottles)	•
Sliding shelves	4
<b>POWER RATING</b>	
Max power absorbed at 220 V	160W
Power supply (V - Hz)	220-240 / 50
Plug (Schuko)	•
<b>DIMENSIONS</b>	
Height (min - max) mm	820 / 870
Width (mm)	595
Depth (mm)	570
Built-In Cut Out (W x L x D) mm	(from 830 to 880) x 600 x 595

# WINE CELLARS

WINE CELLAR 88



FWC 8800 TC ...	
Type	Wine cellar
Finish	Built-In
Bottle no. (Ø 76 mm)	40
Door finish	Stainless steel Black Glass <b>BKX</b> <b>GBK</b>
Reversible door	•
<b>PERFORMANCE</b>	
Cooling system	Ventilated
Temperature zones	2
Adjustable upper zone temperature (°C)	from 5 to 20
Adjustable lower zone temperature (°C)	from 5 to 20
Efficiency class	G
Anti-vibration system	•
Anti-condensation system	•
Climate class	SN-T
Sound level dB (A) re1pW	40
<b>CONTROL SYSTEM</b>	
Electronic regulation	•
Digital touch display	•
Double automatic hot / cold circuit	•
Control light indicator	•
<b>ACCESSORIES</b>	
UV-insulating glass pane	•
Lighting	LED
Wooden shelves / type	5 / Beech
Champagne shelf (4 bottles)	•
Sliding shelves	5
<b>POWER RATING</b>	
Max power absorbed at 220 V	160W
Power supply (V - Hz)	220-240 / 50
Plug (Schuko)	•
<b>DIMENSIONS</b>	
Height (mm)	885
Width (mm)	590
Depth (mm)	555
Built-In Cut Out (W x L x D) mm	888 x 565 x 575

# DISHWASHING

DISHWASHER

NEW



NEW



	FDW 82914 TC	FDW 82914 TC - SD
Type	Fully integrated	Fully integrated Sliding
<b>ENERGY CONSUMPTION</b>		
Efficiency class	A	A
Inverter Motor	•	•
Electrical diverter	•	•
Water consumption (litre / cycle)	9L	9L
Estimated annual energy consumption (Kwh)	292	292
Estimated annual water consumption (litres)	2.520L	2.520L
Sound level dB (A)	42	42
<b>MAIN FEATURES</b>		
Max places setting n.	14	14
Touch controls	•	•
Interior light	•	•
Delayed start	•	•
Door opening system (Autodoor)	•	•
End of cycle detection floor light/buzzer	•	•
Drying with door auto-opening	•	•
Cold/hot water supply (max 60°C)	•	•
<b>FUNCTIONS AND PERFORMANCE</b>		
Washing programs no.	9	9
Fast cycles	•	•
Auto 45 - 65° C	•	•
Half load (for all programs)	•	•
Super 50-65°C	•	•
Drying system	With residual heat	With residual heat
<b>SAFETY SYSTEM</b>		
Water safety	•	•
Salt indicator /rinse aid indicator	•	•
Child lock	•	•
Antibacterial filter	•	•
Water softener adjustable program	•	•
Machine clean programme	•	•
<b>POWER RATING</b>		
Voltage / Frequency (V - Hz)	220 - 240 / 50	220 - 240 / 50
Power cord (m) / Plug	1.4 / •	1.4 / •
<b>DIMENSIONS, INSTALLATION AND PACKAGING</b>		
Product Height (mm.)	820 - 870	820 - 870
Product Width (mm.)	598	598
Product Depth (mm.)	570	570
Built-in Cut out (W x H xD) mm.	600 x 820-870 x 600	600 x 570 x 820-870
Door height	647 - 717	727-797
Gross weight (Kg)	39,5	39,5
External packaging type	Cardboardbox	Cardboardbox
Packaging dimensions : H X W X D	856 x 660 x 675	856 x 660 x 675

# DISHWASHING

DISHWASHER

NEW



	FDW 82914 PB
Type	Fully integrated
<b>ENERGY CONSUMPTION</b>	
Efficiency class	A
Inverter Motor	•
Electrical diverter	•
Water consumption (litre / cycle)	9L
Estimated annual energy consumption (Kwh)	292
Estimated annual water consumption (litres)	2.520L
Sound level dB (A)	49
<b>MAIN FEATURES</b>	
Max places setting n.	14
Electronic buttons	•
Interior light	•
Delayed start	•
Door opening system (Autodoor)	•
End of cycle detection floor light/buzzer	•
Drying with door auto-opening	•
Cold/hot water supply (max 60°C)	•
<b>FUNCTIONS AND PERFORMANCE</b>	
Washing programs no.	9
Fast cycles	•
Auto 45 - 65° C	•
Half load (for all programs)	•
Super 50-65°C	•
Drying system	With residual heat
<b>SAFETY SYSTEM</b>	
Water safety	•
Salt indicator /rinse aid indicator	•
Child lock	•
Antibacterial filter	•
Water softener adjustable program	•
Machine clean programme	•
<b>POWER RATING</b>	
Voltage / Frequency (V - Hz)	220 - 240 / 50
Power cord (m) / Plug	1.4 / •
<b>DIMENSIONS, INSTALLATION AND PACKAGING</b>	
Product Height (mm.)	820-870
Product Width (mm.)	598
Product Depth (mm.)	570
Built-in Cut out (W x H xD) mm.	600 x 820-870 x 600
Door height (mm.)	647-717
Gross weight (Kg)	39,5
External packaging type	Cardboardbox
Packaging dimensions : H X W X D	856 x 660 x 675

## DESIGNED IN ITALY



UGO MARINELLO

IDA Award winning designer Ugo Marinello is passionate about his work and his desire to synthesize modern rationality with traditional design. A graduate of IUAV in Venice, he draws inspiration from the unique architecture of that city, using it as a foundation to bring innovative yet timeless design and quintessential Italian spirit to your home and kitchen throughout the Fulgor Milano line.



ALFRED HENDRICKX

Known internationally for his mid-century furniture collections, designer Alfred Hendrickx began incorporating the strong lines of industrial styling and materials like stainless steel early in his career. After many successful design collaborations in Europe, he turned his attention to the design of household appliances, notably marrying modern form and function for Meneghetti and Fulgor Milano.

**FULGOR**  
MILANO

Rosà - Vicenza - Italy

[www.fulgor-milano.com](http://www.fulgor-milano.com)

[info@fulgor-milano.com](mailto:info@fulgor-milano.com)